

# **SUMO** Rippa

## 3.0m & 4.0m



Parts list 2017  
and  
Operators Manual

**SUMO**  
**UK LIMITED**  
Agricultural Machinery Manufacturers

[www.sumo1.com](http://www.sumo1.com)

Redgates  
Melbourne  
York  
YO42 4RG  
Tel. 01759 319900  
Fax. 01759 319901





**In order to obtain your free pair of Sumo overalls and baseball cap**  
please fill in this form and send back to us at:

Sumo UK Ltd  
Redgates  
Melbourne  
York  
YO42 4RG  
Tel. 01759 319900  
Fax. 01759 319901



SUMO SERIAL No:

Overall size:  
tick where  
applicable

|                        |  |
|------------------------|--|
| Small (38 chest)       |  |
| Medium (42 chest)      |  |
| Large (46 chest)       |  |
| Extra large (50 chest) |  |
| XX Large (54 chest)    |  |
| XXX Large (58 chest)   |  |

NAME:

ADDRESS:



## 2.0 Summary

The Sumo Rippa is a useful tool ideally suited to the potato grower, the Sumo Rippa is used after ploughing to mix and aerate the soil ahead of bed formers or tillers. It can also be used for primary cultivation post-harvest and can work down to 14-16in to remove plough pan compaction.

Before using the SUMO Rippa it is absolutely necessary that you read this Operators manual and Safety Instructions attentively.

Specifications, descriptions and illustrations in this brochure are accurate, as known, at the time of publication but may be subject to change.

## Contents

|                                 |       |
|---------------------------------|-------|
| 3.0 Safety                      | ...6  |
| 3.1 Qualification and Training  | ...6  |
| 3.2 General Safety              | ...7  |
| 3.3 Special Safety Instructions | ...7  |
| 4.0 Operation and Adjustments   | ...8  |
| 4.1 Operating                   | ...8  |
| 4.2 Adjustments                 | ...8  |
| 5.0 Maintenance                 | ...9  |
| 5.1 Spares                      | ...9  |
| 5.2 Winter Storage              | ...9  |
| 6.0 Parts and Assembly          | ...10 |
| 6.1 Overview                    | ...10 |
| 6.2 Point Assembly              | ...11 |
| 6.3 Leg and Shear Bar Assembly  | ...12 |
| 6.4 Depth Control               | ...13 |
| 6.5 Steel Wheel Assembly        | ...14 |
| 6.6 Tyre and Wheel Alternative  | ...15 |
| 6.7 Main Frame                  | ...16 |
| 6.8 Stickers and Paint          | ...17 |

## **3.0 Safety**

This manual contains basic advice, which should be observed during setting-up, operation and maintenance. Therefore, this operating manual must be read by the personnel concerned prior to starting up and using the machine and be available at all times.

If safety instructions are not complied with, then this can lead to the risk of injury to yourself and others as well as damage to the environment or the machine. Non-compliance to the safety instructions can also lead to claims for damages becoming invalid.

### **3.1 Qualification and Training**

- Reliable personnel may only perform any work on, or, with the machine. Statutory minimum age limits must be observed.
- Employ only trained or instructed staff; the individual responsibilities of the personnel concerning operation, setting up, maintenance and repair must be clearly established.
- Make sure that only authorized personnel work on or with the machine.
- Define the machine operators' responsibilities – also with regard to observing traffic regulations. The operator must have the authority to refuse any instructions issued by third parties, which contravene safety.
- Persons undergoing training or instruction or taking part in a general training course should not be allowed to work on or with the machine unless they are under the constant supervision of an experienced person.
- The use of spare parts, accessories and ancillary equipment not supplied and/or not approved by SUMO could have detrimental effects to the construction of the SUMO machine or on its functions and hence impair the active and/or passive driving and/or operational safety (accident prevention).
- SUMO shall not be responsible for any damage caused by the use of spare parts, accessories and ancillary equipment not supplied and/or approved by SUMO.
- Conversions of or modifications to the machine may only be carried out after consultation with SUMO.

### 3.2 General safety

- Warning signs and other notices on the machine provide important information for the safe operation. Observing them will serve your safety.
- Before starting work, make yourself familiar with all the equipment and controls as well as their functions.
- The user should wear close-fitting clothing.
- Check around the machine before moving off or starting up (watch out for children!). Make sure you have adequate all-round visibility.
- Always match your speed to the local conditions. Avoid sudden turning manoeuvres when driving uphill or downhill or when travelling across a slope.
- Observe the respective regulations when using public roads.
- Take into account the wide overhang and/or the sideways force acting on the machine when turning or negotiating curves.

### 3.3 Special safety instructions

- Take extreme care when hitching up or unhitching machine to/from the tractor.
- Never allow persons to stand between the tractor and the machine unless the tractor is secured against rolling away by means of parking brake and/or wheel chocks.
- It is forbidden to allow persons to ride on the machine at any time. A safe distance should be maintained from the machine by observers when in work.
- Driving, steering and braking characteristics are influenced by mounted machines and ballast weights. Therefore, ensure adequate steering and braking ability.
- Never stand or work beneath suspended loads.



## **4.0 Operation and Adjustment**

### **4.1 Operating**

Due to the physical nature of the Sumo Rippa **a category three enclosed ball top link is highly recommended** as the best option for dealing with the exaggerated loads experienced during normal working conditions.

The top link should be as short as possible whilst remaining as close to horizontal as is achievable. In the majority of cases this means using the bottom hole on the Rippa and the top hole on the tractor. It is important to ensure the machine is running level to allow the optimum level of soil disturbance as well as to prolong the life of the wearing parts.

The Rippa is fitted with reversible points and once worn can be flipped over. In order to flip over or change the points first the Rippa must be secured as not to cause any harm to the operator when working on the machine. Also the tractor engine must be turned off with the parking brake applied. In order to change the points it is first necessary to remove the two nuts and bolts behind the leg freeing the worn part. Then the point can be either be flipped over or replaced with a new point in the same position, with the appropriate nut and bolt tightened up to secure the point in position. The Rippa tines are protected with a shear bolt located through the leg and in the event of one breaking it needs to be replaced with the appropriated nut and bolt (see 6.3 Leg & Shear bolt Assembly).

Forward working speed should be governed by the local conditions.

### **4.2 Adjustments**

Depth adjustment of the Rippa is achieved by altering the height at which the pair of pneumatic depth wheels are set by using a unique pin system (see 6.4 Depth Control page 11). This and a combination of the top link length and lower linkage height help to change the depth of the machine. Always ensure the machine is working level to achieve uniform results.

## **5.0 Maintenance**

The condition of the Rippa legs and the points should be regularly monitored in order to maintain the most efficient use of the machine.

Wheel nuts should be regularly checked and tightened if necessary.

### **5.1 Spares**

When ordering replacement parts please have your serial number, part numbers (listed in Section 6.0) and quantities at hand.

### **5.2 Winter storage**

When machines are to be parked up for the winter period, correct storage techniques are an important part of protecting the machine to ensuring a hassle free season. When the machine has finished work it should be cleaned down and washed off to remove all traces of soil.

Following washing of the packer bearings should be greased with one pump if fitted. Other grease points are located on the depth wheel pivots.

Wheel studs should be checked that they are tight.

When the machine is parked up a note should be made of what wearing parts require replacing ready for the next seasons work. The wearing parts can then be ordered in time ready for the next season's work in good time to avoid delays when the machine is required earlier than expected!

## 6.0 Parts and Assembly

### 6.1 Overview

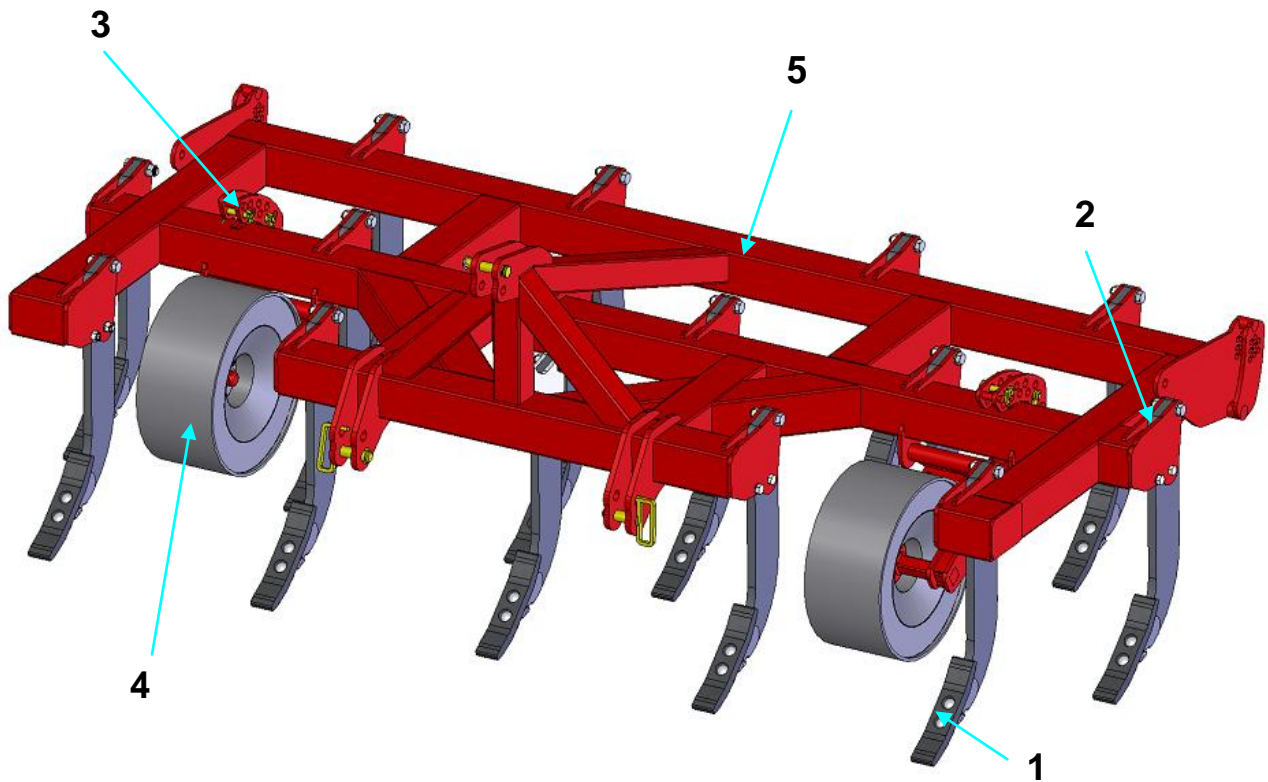

| Item | Description               | Page |
|------|---------------------------|------|
| 1    | Point Assembly            | 9    |
| 2    | Leg & Shear bolt Assembly | 10   |
| 3    | Depth Control             | 11   |
| 4    | Wheel Assembly            | 12   |
| 5    | Main Frame                | 13   |

## 6.2 Point Assembly

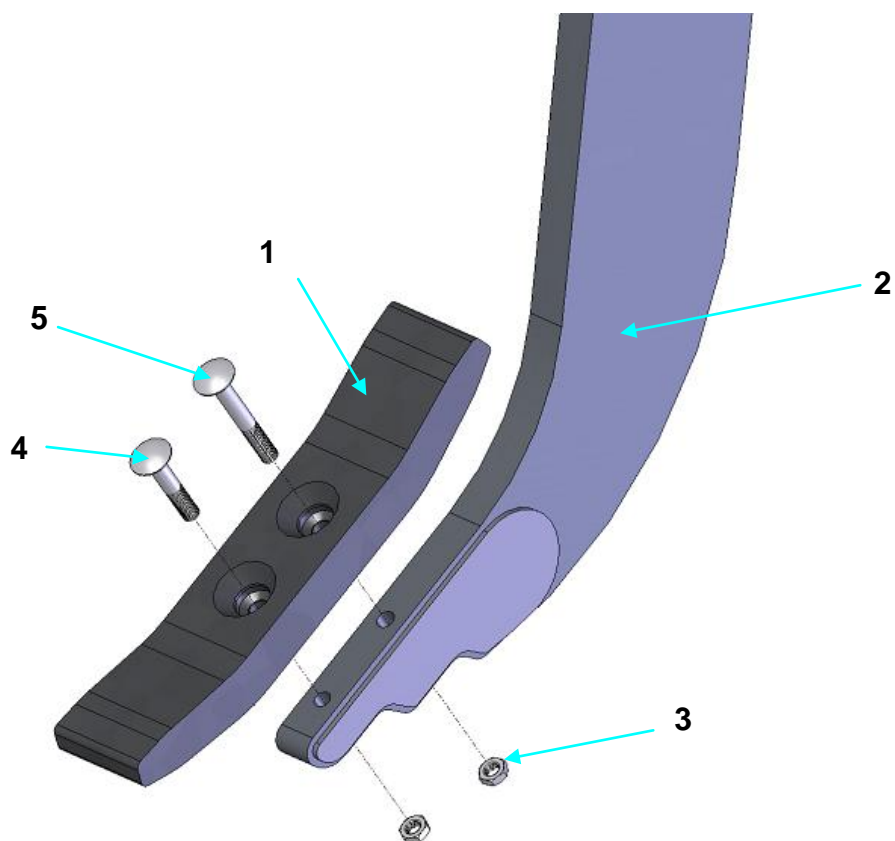

| Item | Part No.  | Description              | Quantity/3 m machine | Quantity/4 m machine |
|------|-----------|--------------------------|----------------------|----------------------|
| 1    | SW195     | Rippa Point              | 11                   | 15                   |
| 2    | SW271     | Rippa leg                | 11                   | 15                   |
| 3    | SWM12003  | M12 plain nut            | 22                   | 30                   |
| 4    | SWM1265PB | M12x65 plough bolt short | 11                   | 15                   |
| 5    | SWM1290PB | M12x90 plough bolt long  | 11                   | 15                   |

### 6.3 Leg and Shear Bolt Assembly

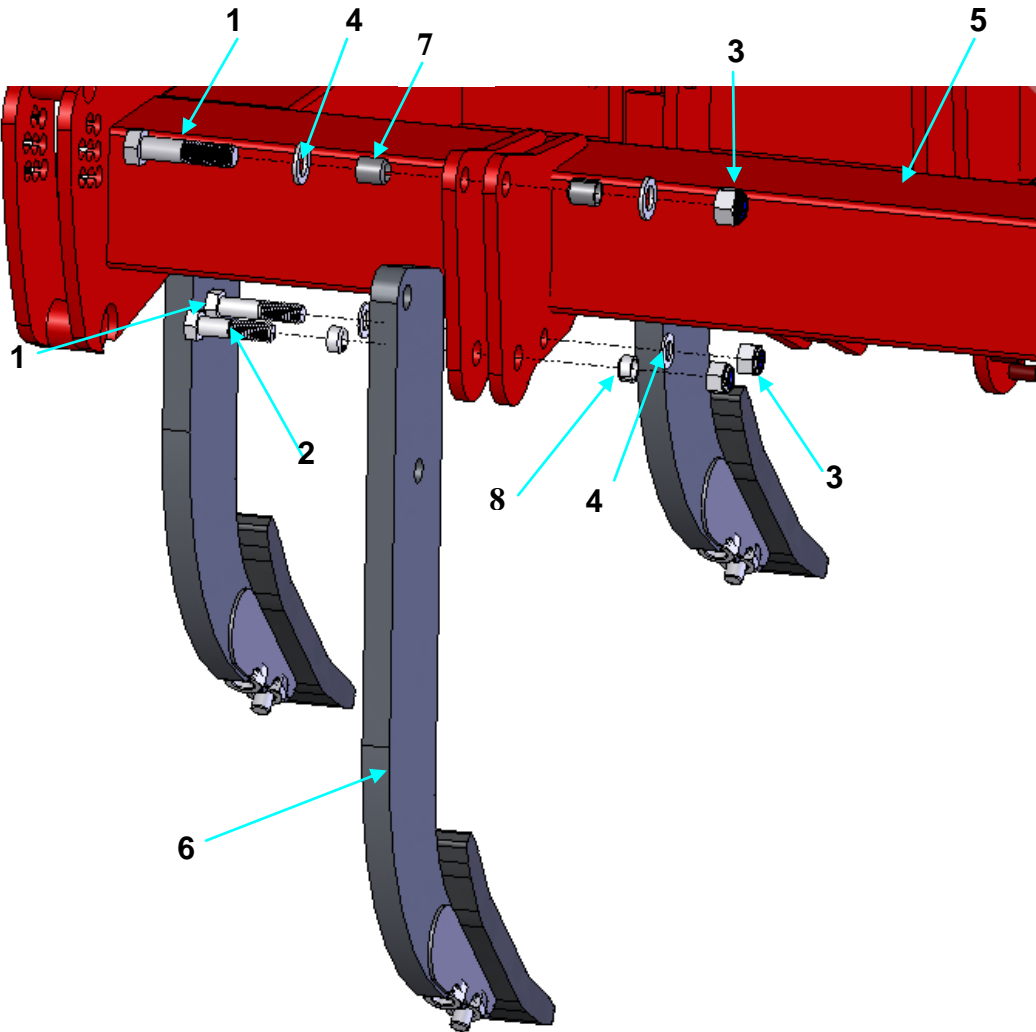

| Item | Part No.  | Description              | Quantity/3m machine | Quantity/4m machine |
|------|-----------|--------------------------|---------------------|---------------------|
| 1    | SWM20100  | M20 x 100 bolt           | 22                  | 30                  |
| 2    | SWM2090SB | Rippa Shear Bolt         | 11                  | 15                  |
| 3    | SWM20004  | M20 nylock nut           | 33                  | 45                  |
| 4    | SWM20001  | M20 flat washer          | 44                  | 60                  |
| 5    | SW272     | Rippa 3m main frame      | 1                   | N/A                 |
|      | SW273     | Rippa 4m main frame      | N/A                 | 1                   |
| 6    | SW271     | Rippa leg                | 11                  | 15                  |
| 7    | SW791     | 30mm Spring tension bush | 22                  | 30                  |
| 8    | SW790     | 15mm Spring tension bush | 22                  | 30                  |

## 6.4 Depth Control

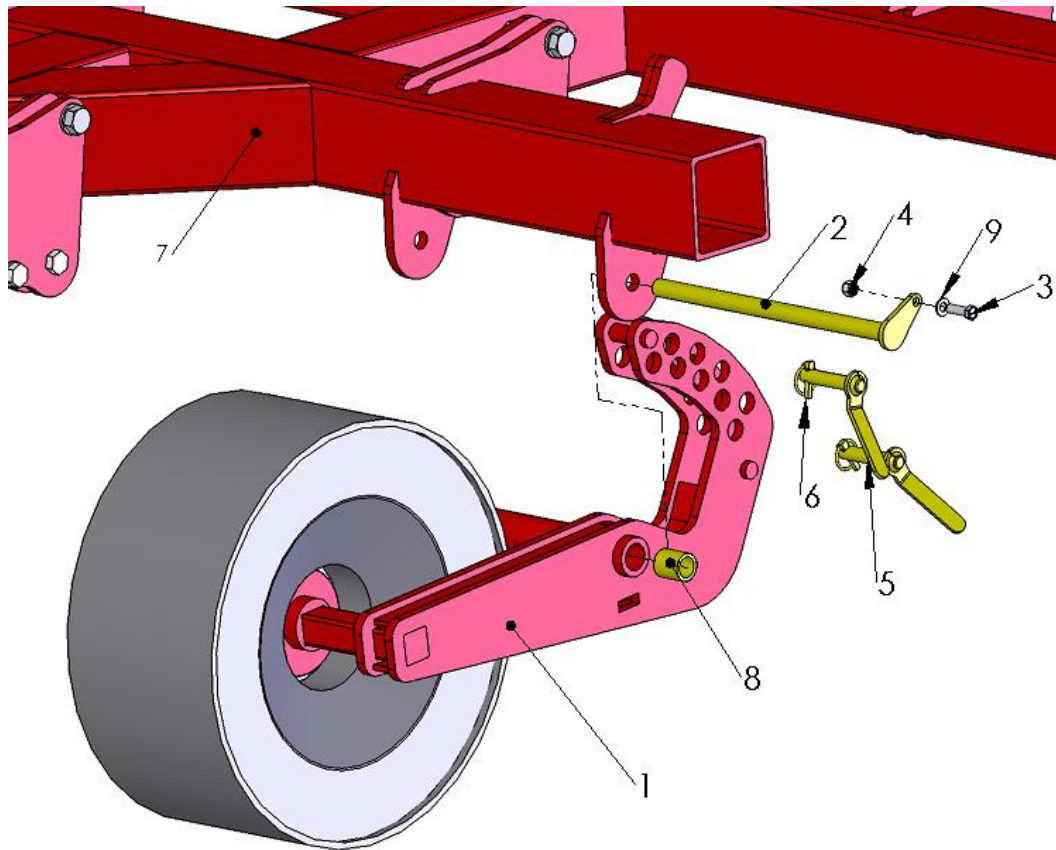

| Item | Part No. | Description                | Quantity/3m machine | Quantity/4m machine |
|------|----------|----------------------------|---------------------|---------------------|
| 1    | SW585    | Rippa wheel depth arm      | 2                   | 2                   |
| 2    | SW275    | Rippa wheel long pivot pin | 2                   | 2                   |
| 3    | SWM1240  | M12x40 bolt                | 2                   | 2                   |
| 4    | SWM12003 | M12 plain nut              | 2                   | 2                   |
| 5    | SW276    | Rippa depth pin            | 4                   | 4                   |
| 6    | SWB105   | Linch Pin                  | 4                   | 4                   |
| 7    | SW272    | Rippa 3m main frame        | 1                   | N/A                 |
|      | SW273    | Rippa 4m main frame        | N/A                 | 1                   |
| 8    | SWB176   | 30x40x45 oilite bush       | 4                   | 4                   |
| 9    | SWM12001 | M12 flat washers           | 4                   | 4                   |

## 6.5 Steel Wheel Assembly

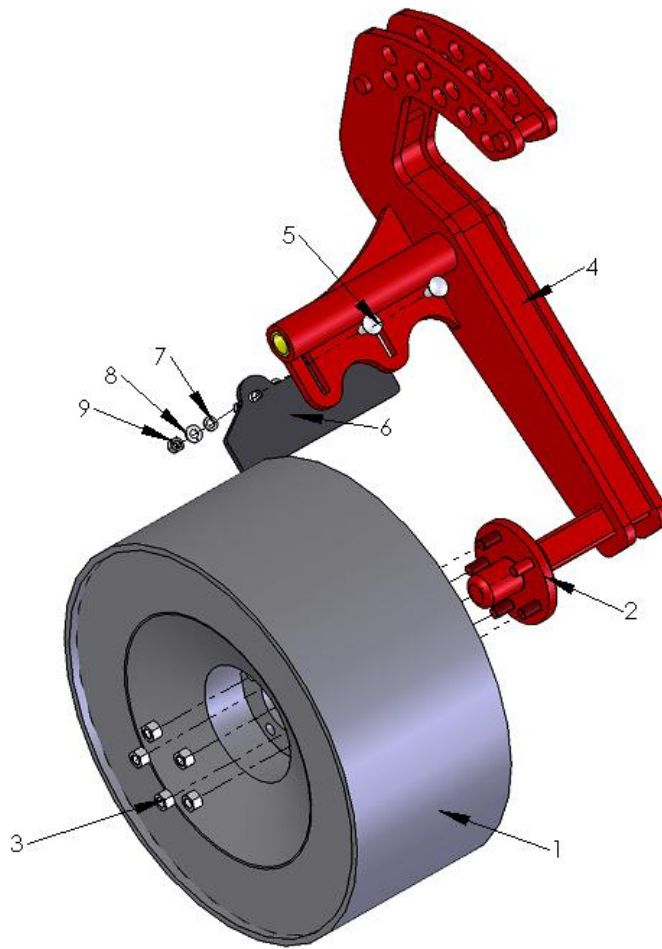

| Item | Part No.     | Description                                | Quantity/3 m machine | Quantity/4 m machine |
|------|--------------|--|----------------------|----------------------|
| 1    | SW584        | Rippa 5 stud 609mm depth wheel             | 2                    | 2                    |
| 2    | SWB151       | Rippa 5 stud hub unbraked complete         | 2                    | 2                    |
| 3    | SWB153       | Rippa wheel studs                          | 10                   | 10                   |
| 4    | SW585        | Ripper LH steel depth wheel arm            | 1                    | 1                    |
|      | SW586        | Ripper LH steel depth wheel arm(not shown) | 1                    | 1                    |
| 5    | SWM1235chsqa | M12x35 cup head square bolt                | 4                    | 4                    |
| 6    | SW587        | Ripper steel wheel scraper                 | 2                    | 2                    |
| 7    | SWM12001     | M12 flat washer                            | 4                    | 4                    |
| 8    | SWM12002     | M12 spring washer                          | 4                    | 4                    |
| 9    | SWM12003     | M12 plain nut                              | 4                    | 4                    |

## 6.6 Tyre and Wheel Assembly

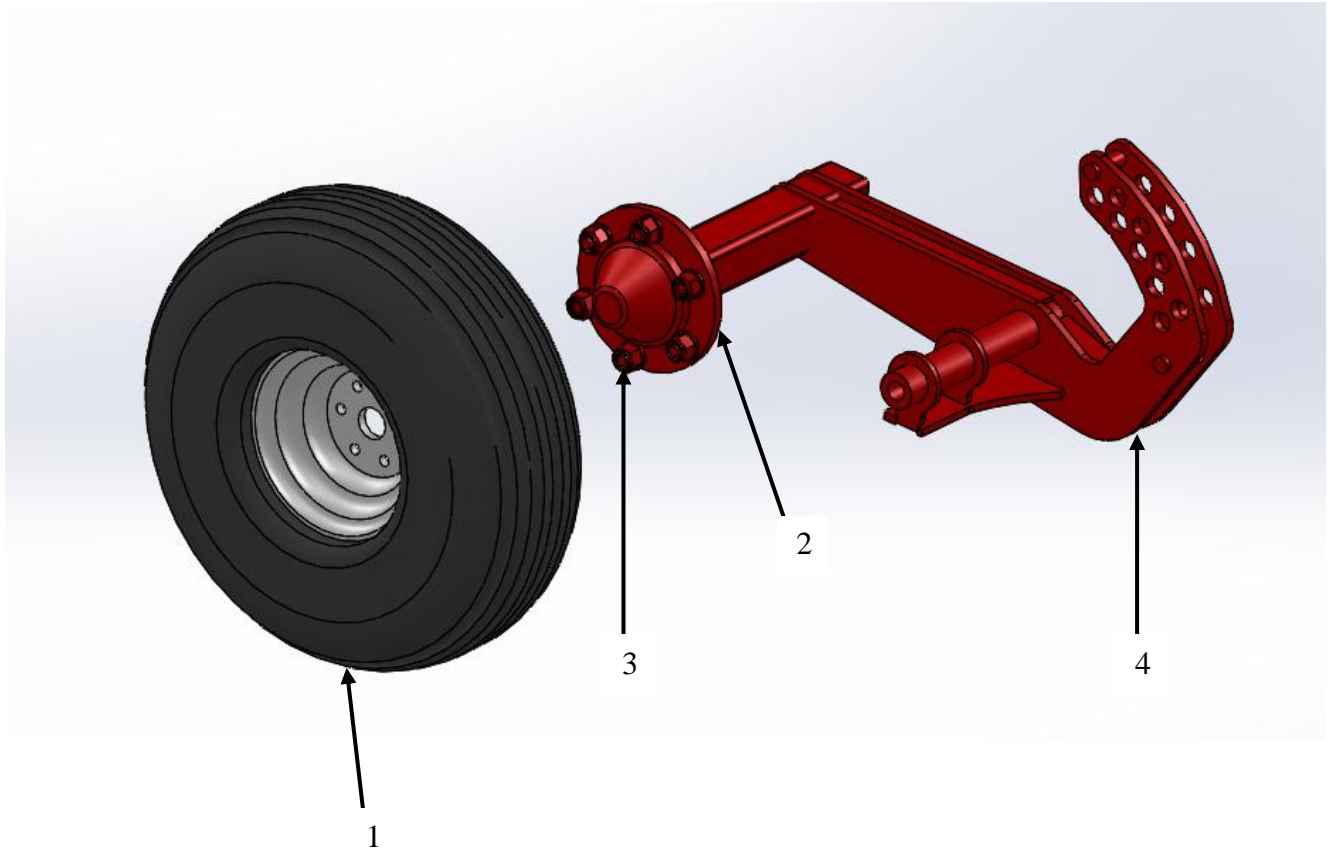

| Item | Part No. | Description                                 | Quantity/3 m machine | Quantity/4 m machine |
|------|----------|---|----------------------|----------------------|
| 1    | SWB639   | Rippa 6 stud Depth Wheel                    | 2                    | 2                    |
| 2    | SWB258   | Rippa 6 stud hub unbraked complete          | 2                    | 2                    |
| 3    | SWB153   | Rippa wheel studs                           | 12                   | 12                   |
| 4    | SW585    | Ripper RH steel depth wheel arm (not Shown) | 1                    | 1                    |
|      | SW586    | Ripper LH steel depth wheel arm             | 1                    | 1                    |





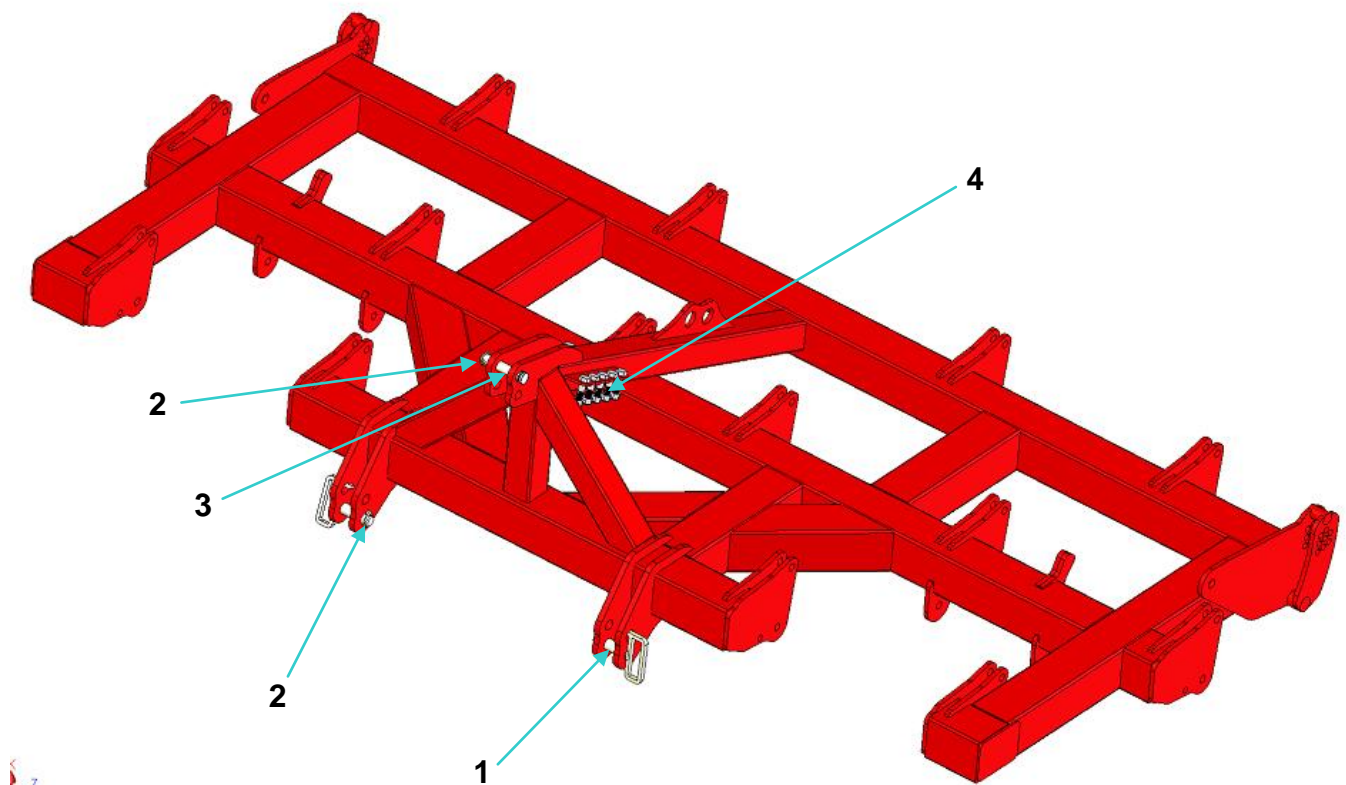

## 6.7 Main Frame



| Item | Part No.  | Description              | Quantity/3m machine | Quantity/4m machine |
|------|-----------|--------------------------|---------------------|---------------------|
| 1    | SW132     | Cat III lower link pin   | 2                   | 2                   |
| 2    | SWB107    | Cat III safety lynch pin | 3                   | 3                   |
| 3    | SW133     | Cat III top link pin     | 1                   | 1                   |
| 4    | SWM2090SB | Spare Rippa Shear Bolts  | 10                  | 10                  |

## 6.8 Stickers and Paint

| Sticker   | Description                                | Quantity  | Part No. |
|---|--|-----------|----------|
|    | Big Sumo horizontal sticker<br>450 x 125mm | 3         | SWB125   |
|    | Vertical Sumo sticker<br>80 x 295mm        | 2         | SWB128   |
|   | Large Union Jack sticker                   | 2         | SWB127   |
|  | Horizontal Rippa Sticker                   | 4         | SWB154   |
| Touch up paint  | Sumo Red                                   | 1/2 litre | SWB131   |
|   | Sumo Black                                 | 1/2 litre | SWB132   |