



# SUBSOILER



3,4,5 and 7 Leg Mounted  
Subsoiler

**2014**  
**Operator Manual**  
**and**  
**Parts List**



[www.sumo1.com](http://www.sumo1.com)

Redgates  
Melbourne  
York  
YO42 4RG  
Tel. 01759 319900  
Fax. 01759 319901



## 1.0 Registration

**To activate your SUMO Warranty**, you must complete this page and send it back to us at:

Sumo UK Ltd  
Redgates  
Melbourne  
York  
YO42 4RG  
Tel. 01759 319900  
Fax. 01759 319901

**(NO REGISTRATION = NO WARRANTY)**

SUMO SERIAL No:

For your own records.

(Serial plate on side of headstock)



### Sumo Subsoiler Registration Document

NAME:

ADDRESS:

Postcode:

DATE:

SUMO SERIAL No.

(Serial plate on side of headstock)

DEALERSHIP  
NAME AND  
BRANCH:

COMMENTS:



**In order to obtain your free pair of Sumo overalls and baseball cap** please fill in this form and send back to us at:

Sumo UK Ltd  
Redgates  
Melbourne  
York  
YO42 4RG  
Tel. 01759 319900  
Fax. 01759 319901



SUMO SERIAL No:

Overall size:  
tick where applicable

Small (38 chest)	
Medium (42 chest)	
Large (46 chest)	
Extra large (50 chest)	
XX Large (54 chest)	
XXX Large (58 chest)	

NAME:

ADDRESS:



## 2.0 Summary

All the subsoilers feature a strong V shaped frame which lets soil and trash flow more efficiently, allowing the legs to be run closer together giving total loosening. This aggressive action increases the aeration, leaving a surface 50 - 100mm raised up. The Sumo range of Subsoilers can be used successfully as a primary and a secondary source of cultivation, leaving the surface weather proof and ready to drill.

Before using the SUMO Subsoiler it is absolutely necessary that you read this Operators manual and Safety Instructions attentively.

Specifications, descriptions and illustrations in this brochure are accurate, as known, at the time of publication but may be subject to change.

## Table of Contents

1.0 Registration	...Page 1
2.0 Summary	...Page 3
3.0 Safety	...Page 5
3.1 Qualification and Training	...Page 5
3.2 General Safety	...Page 6
3.3 Special Safety Instructions	...Page 6
3.4 Risk Assessment	...Page 7
4.0 Operation and Adjustment	...Page 8
4.1 Operating	...Page 8
4.2 Adjustments	...Page 8
4.3 Auto Reset	...Page 8
5.0 Maintenance	...Page 9
5.1 Spares	...Page 9
5.2 Winter Storage	...Page 9
6.0 Parts and Assembly	...Page 10
6.1 Auto Reset Assembly	...Page 10
6.2 Shear Bar Assembly	...Page 11
6.3 Leg and Point Assembly	...Page 12
6.4 Packer Bearing Assembly	...Page 13
6.5 Packer Depth Assembly	...Page 14
6.6 Scraper Assembly	...Page 15
6.7 Light Assembly	...Page 16
6.8 Main Frame	...Page 17
6.9 Hydraulics – 3 Leg	...Page 18
6.10 Hydraulics – 4 Leg	...Page 19
6.11 Hydraulics – 5 Leg	...Page 20
6.12 Hydraulics – 7 Leg	...Page 21
6.13 Stickers	...Page 24

## **3.0 Safety**

This manual contains basic advice, which should be observed during setting-up, operation and maintenance. Therefore, this operating manual must be read by the personnel concerned prior to starting up and using the machine and be available at all times.

If safety instructions are not complied with, then this can lead to the risk of injury to yourself and others as well as damage to the environment or the machine. Non-compliance to the safety instructions can also lead to claims for damages becoming invalid.

### **3.1 Qualification and Training**

- Reliable personnel may only perform any work on, or, with the machine. Statutory minimum age limits must be observed.
- Employ only trained or instructed staff; the individual responsibilities of the personnel concerning operation, setting up, maintenance and repair must be clearly established.
- Make sure that only authorized personnel work on or with the machine.
- Define the machine operators' responsibilities – also with regard to observing traffic regulations. The operator must have the authority to refuse any instructions issued by third parties, which contravene safety.
- Persons undergoing training or instruction or taking part in a general training course should not be allowed to work on or with the machine unless they are under the constant supervision of an experienced person.
- The use of spare parts, accessories and ancillary equipment not supplied and/or not approved by SUMO could have detrimental effects to the construction of the SUMO machine or on its functions and hence impair the active and/or passive driving and/or operational safety (accident prevention).
- SUMO shall not be responsible for any damage caused by the use of spare parts, accessories and ancillary equipment not supplied and/or approved by SUMO.
- Conversions of or modifications to the machine may only be carried out after consultation with SUMO.

### **3.2 General safety**

- Warning signs and other notices on the machine provide important information for the safe operation. Observing them will serve your safety.
- Before starting work, make yourself familiar with all the equipment and controls as well as their functions.
- The user should wear close-fitting clothing.
- Keep the machine and in particular the bearings clean to avoid risk of fire.
- Check around the machine before moving off or starting up (watch out for children!). Make sure you have adequate all-round visibility.
- Always match your speed to the local conditions. Avoid sudden turning manoeuvres when driving uphill or downhill or when travelling across a slope.
- Observe the respective regulations when using public roads.
- Take into account the wide overhang and/or the sideways force acting on the machine when turning or negotiating curves.

### **3.3 Special safety instructions**

- Take extreme care when hitching up or unhitching machine to/from the tractor.
- Never allow persons to stand between the tractor and the machine unless the tractor is secured against rolling away by means of parking brake and/or wheel chocks.
- During transport, secure the packer (using both pins) to prevent shock loading when encountering road undulations. Ensure stands are raised to their transport position.
- It is forbidden to allow persons to ride on the machine at any time. A safe distance should be maintained from the machine by observers when in work.
- Driving, steering and braking characteristics are influenced by mounted machines and ballast weights. Therefore, ensure adequate steering and braking ability.
- Never stand or work beneath suspended loads. Ensure stands are in position before commencing maintenance work.

**Model:** Mounted Subsoiler

**Year:** 2012



### 3.4 RISK ASSESSMENT

**Date assessment written:** 16<sup>th</sup> February 2012

**Assessor:** R. A. Hight

**Notes:** Ensure the operator manual is read and fully understood.

**Purpose of machine:** Primarily designed to alleviate compaction and improve soil structure in an agricultural environment.

**Description of machine:** A three-point-linkage mounted farm implement consisting of 2 major elements.

1. A bank of staggered subsoiler legs.
2. A rigid packer roller

All of the above is arranged in a heavy duty fabricated steel framework.

Hazard identified in using machine	Who might be harmed	Risk evaluation/level 1-5	Precautions in place	Further action required
Machine collision while in transport.	Operator, members of the public	2 - low_med	Tail lights, reflectors.	Take care when using in both field and road situations. Maintain good visibility at all times.
Trapped fingers during leg depth position change.	Operator	1 - low	Warnings, maintenance stands	Observe warning signs, maintain safe distance from moving parts, wear gloves. Ensure both of the stands are down. Clear excess soil (weight) from points before attempting to adjust legs.
Risk of crushing: - When coupling a tractor to the Sumo implement. - When changing points.	Operator	4 - med_high	Warnings, maintenance stands	Take extreme care when working on legs, changing depth, replacing points etc, make sure stands are down and the machine is on a suitable firm piece of land. Ensure tractor hydraulics are in good working order. Ensure tractor is safely positioned and the parking brake is engaged when coupling up to the Sumo implement.
Falling from machine	Operator	2 - low_med	Most alterations and maintenance do not require the operator the climb on the machine	Lower the machine to the floor to allow access for greasing discs, checking bearings etc...

## **4.0 Operation and Adjustment**

### **4.1 Operating**

Before attaching a subsoiler to a tractor is essential that the **stands are in the down position** to ensure a short top link once attached. Once attached securely to the tractor the machine can then be raised and the stands lifted out of the way. When the machine is removed from the tractor it is equally as important to leave the machine on the stands.

Due to the physical nature and weight distribution of the Sumo Subsoiler a **category three enclosed ball top link** is highly recommended as the best option for dealing with the exaggerated loads experienced during normal working conditions.

The top link should be as short as possible whilst remaining as close to horizontal as is achievable. In the majority of cases this means using the bottom hole on the Subsoiler and the top hole on the tractor. It is important to ensure the machine is running level to allow the optimum level of soil disturbance as well as to prolong the life of the wearing parts.

Changing the points on the Subsoiler must only be done on level ground. When it is deemed necessary to change the points, the stands should be lowered to the static position and other appropriate jacks, stands and chocks put into position in sensible locations. To avoid the risk of sinking and potential injury it is important to only change the points where ground conditions permit, i.e. solid concrete, tarmac etc. Care should be taken to ensure the subsoiler is firmly and safely held before changing the points. The tractor engine must be turned off with the parking brake applied. In order to change the points it is first necessary to remove the nut and bolt behind the point freeing the worn part. Then a new point can be replaced in the same position, with the appropriate nut and bolt tightened up to secure the point in position.

Bearings should be greased (see 5.0 Maintenance), stands must be in the raised position and all relevant pins in the correct holes prior to commencing work.

Forward working speed should be governed by the local conditions as well as the finish produced by the Subsoiler.

### **4.2 Adjustments**

Depth adjustment of the subsoiler legs is achieved by altering the height at which the packer is set and a combination of the top link length and lower linkage height. The machine should always remain level in when working. The lower packer pin must be placed in the upper-most hole under the packer arm to prevent the arms chasing and wearing in the slots every time the machine is raised. Failure to do this can result in excessive wear to the packer arms, main side plates and the quadrants.

**DO NOT TIGHTEN POINTS UP WITH AIR RACHETS OR OVER TIGHTEN WITH SPANNERS. EXCESSIVE TIGHTENING WILL RESULT IN POINTS CRACKING**

### 4.3 Auto Reset hydraulic circuit

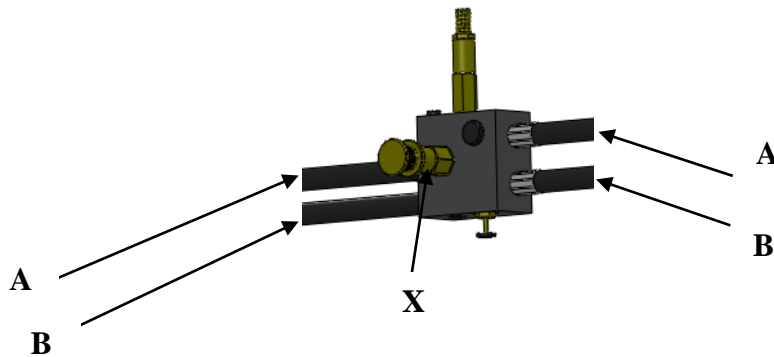
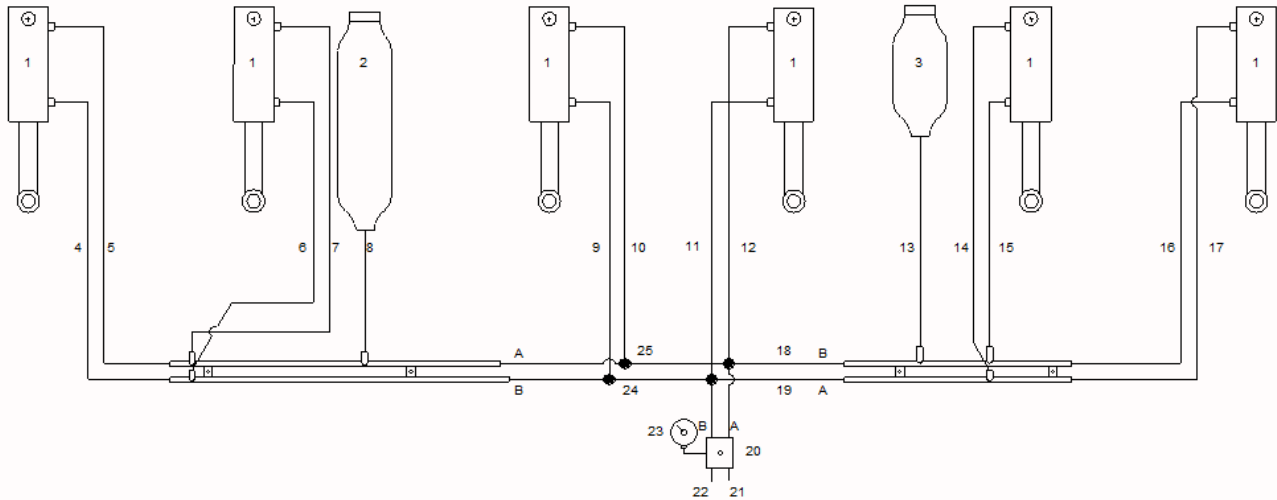

- 1) To lift the legs up and out of the work position; pressurize line B (the lower of the two hoses entering the valve block & marked "B" on the valve itself). The legs will lift as oil is returned to the tractor through Line A.
- 2) To lower the legs back down and into the work position; pressurize line A, the legs will lower one by one. Keep pumping until all of the legs come to a stop at the end of their stroke. Keep pumping for a few more seconds and the two lines will then pressure up. Keep an eye on the gauge on the right hand side of the machine as this displays the leg trip resistant pressure. The system needs then to be put into the "float" or pressureless state between the tractor and the valve so that any back pressure from the tractor does not affect the preset valve pressures. Putting the system into "float" means the factory set pressure readings of 80bar on the full bore side of the ram (gauge on RHS of machine) and 20bar on the rod side of the ram. This is unless of course they have been adjusted to suit local conditions. The resistant pressure is adjustable up to a maximum of 150bar
- 3) To increase the trip resistance of the legs – the knob marked X should be wound in. The lift and lower process should then be repeated.

## **5.0 Maintenance**

The packer bearings should be greased with one pump once a week and after washing off.

The condition of the subsoiler legs and the points should be regularly monitored in order to maintain the most efficient use of the machine.

Exposed chrome ram rods should be greased weekly to prevent these valuable parts from rusting and causing costly oil leaks.

The condition and position of the packer scrapers should also be observed in order to prevent soil building up on the packer. Ensure the scrapers are not touching the packer though, as this will add rolling resistance as well as causing premature wear of the packer.

### **5.1 Spares**

When ordering replacement parts please have your serial number, part numbers (listed in Section 6.0) and quantities at hand.

### **5.2 Winter storage**

When machines are to be parked up for the winter period, correct storage techniques are an important part of protecting the machine to ensuring a hassle free season. When the machine has finished work it should be cleaned down and washed off to remove all traces of soil.

Following washing of the packer bearings should be greased with one pump. Other grease points on auto reset machines are located on both ends of all rams and auto reset pivot hinge bushes; these should receive two or three pumps of grease.

Exposed chrome ram rods should be greased to prevent these valuable parts from rusting over winter and causing costly oil leaks.

When the machine is parked up a note should be made of what wearing parts require replacing ready for the next seasons work. The wearing parts can then be ordered in time ready for the next season's work in good time to avoid delays when the machine is required earlier than expected!

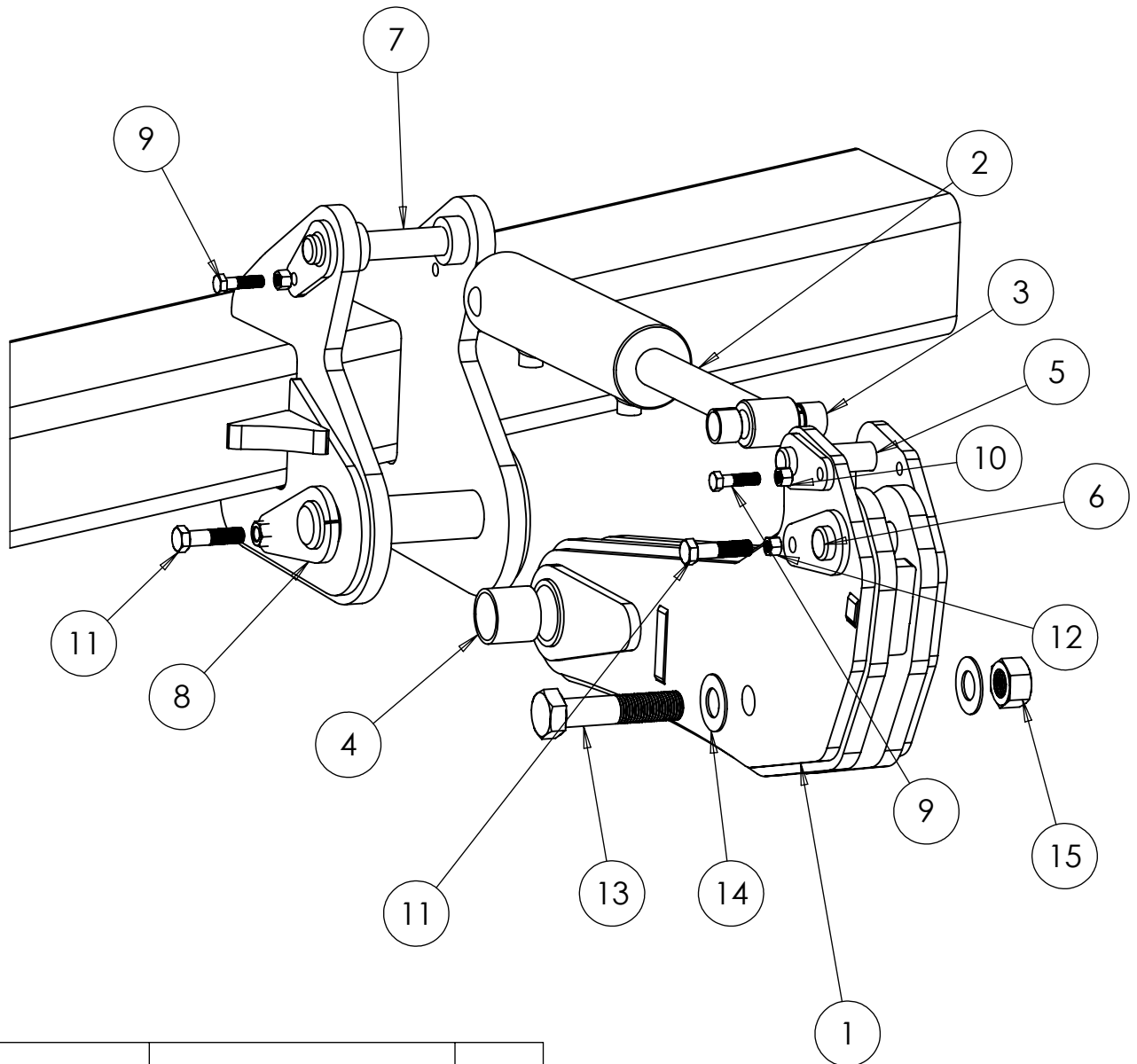

ITEM NO.	PART NO.	DESCRIPTION	QTY.
1	SW399	Auto Reset Socket	1
2	SWH125	705/2 Ram	1
3	SWB374	Spring Tension Bush 30x36x25	2
4	SWB108	PB1 Bush 50x50x58	2
5	SW398	30x125 Tabbed Pin	1
6	SW400	35x125 Tabbed Pin	1
7	SW395	30x165 Tabbed Pin	1
8	SW396	50x230 Tabbed Pin	1
9	SWM1245	M12x45 Bolt	2
10	SWM12004	M12 Nylock Nut	2
11	SWM1665	M16x65 Bolt	2
12	SWM16004	M16 Nylock Nut	2
13	SWM30140	M30x140 Bolt	1
14	SWM30001	M30 Washer	2
15	SWM30004	M30 Nylock Nut	1

DO NOT SCALE DRAWING

MACHINE/COMPONENT:

Mounted Subsoiler

TITLE:

Auto Reset Assembly



Drawings and design information found herein remain the sole property of Sumo UK Ltd. Reproductions may only be made with the permission of the owner.

SCALE 1:7

REVISION:

DATE: 10/12/12

INITIAL: TW

## 6.2 Shear Bar Assembly

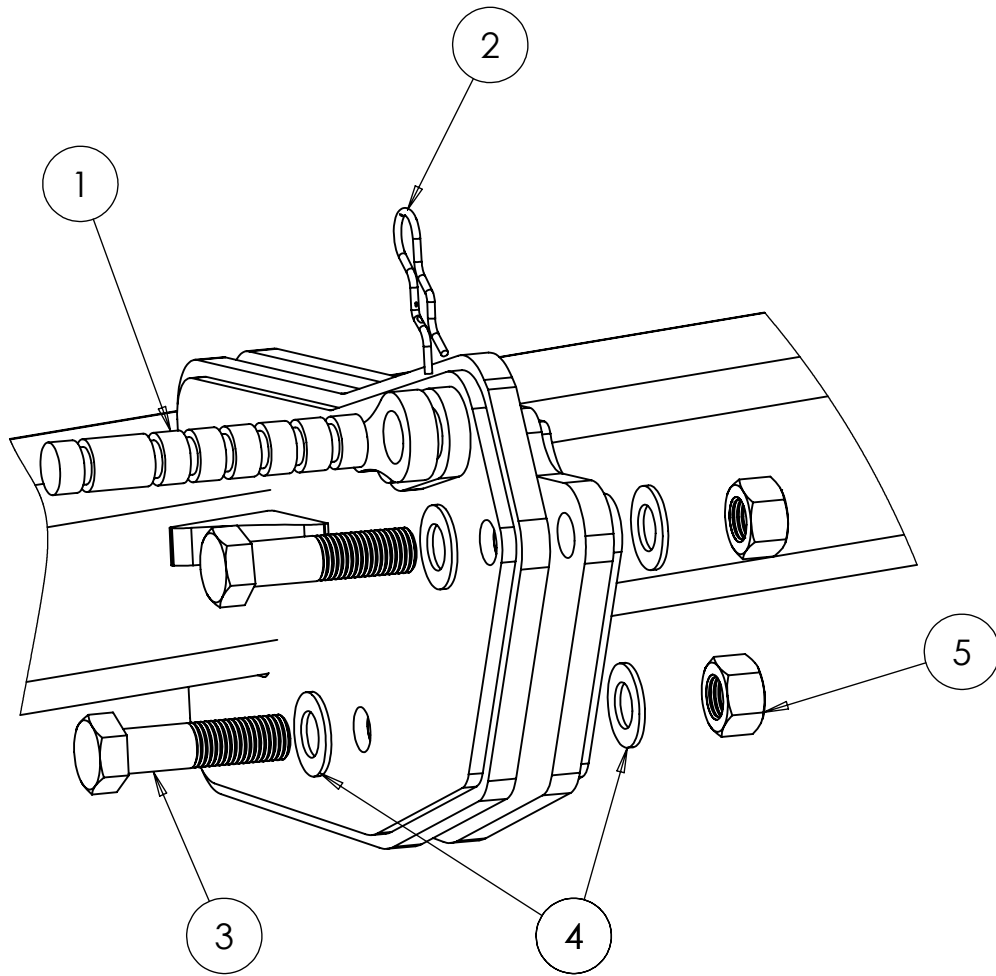

ITEM NO.	PART NO.	DESCRIPTION	QTY.
1	SW355	Subsoiler Shear Bar	1
2	SWB106	Shear Bar R-Clip	1
3	SWM30110	M30 x 110 Bolt	2
4	SWM30001	M30 Washer	4
5	SWM30004	M30 Nylock Nut	2

DO NOT SCALE DRAWING

MACHINE/COMPONENT:

Mounted Subsoiler

TITLE:

Shear Pin Assembly



Drawings and design information found herein remain the sole property of Sumo UK Ltd. Reproductions may only be made with the permission of the owner.

SCALE 1:5

REVISION:

DATE: 7/12/12

INITIAL: TW

## 6.3 Leg and Point Assembly

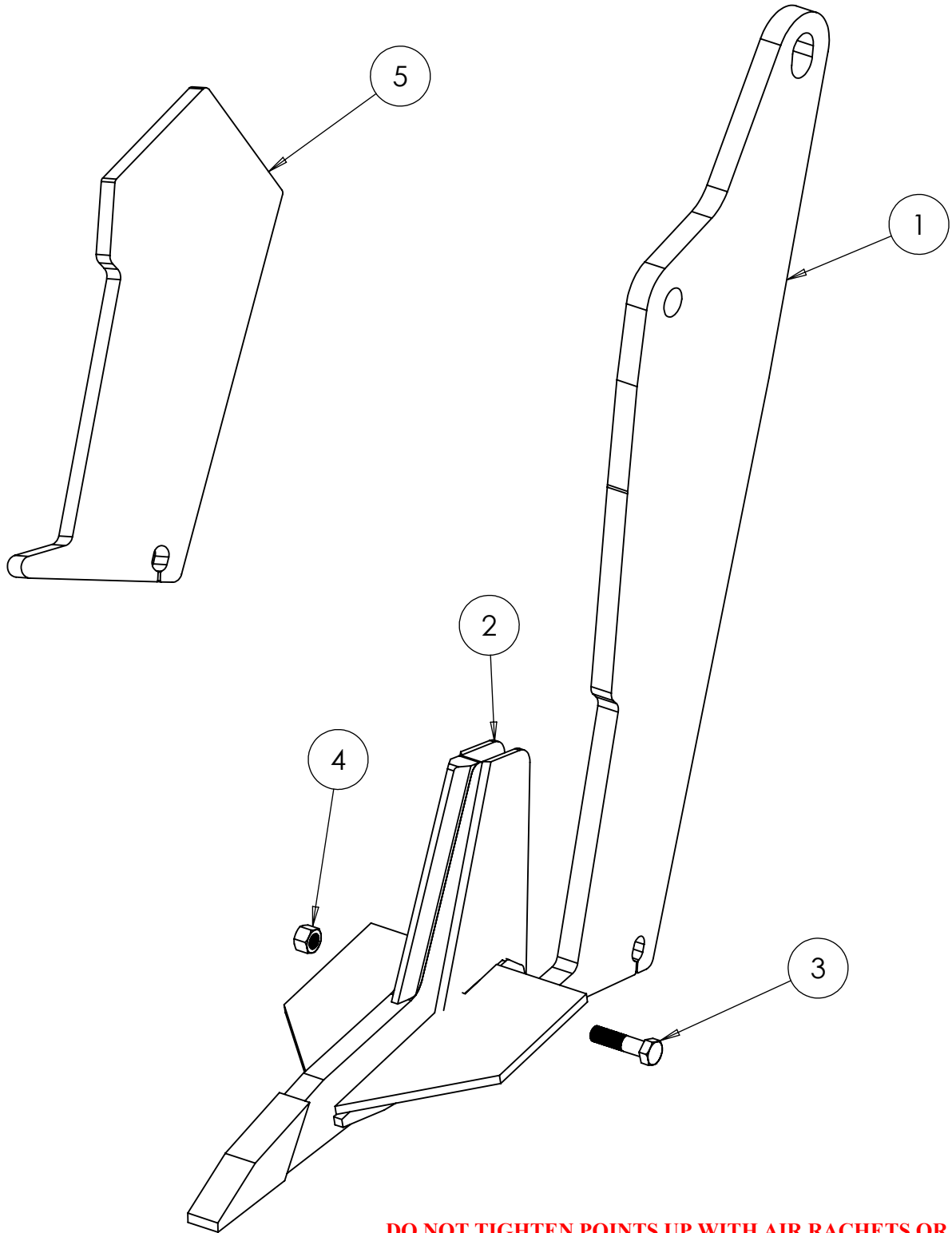

**DO NOT TIGHTEN POINTS UP WITH AIR RACHETS OR  
OVER TIGHTEN WITH SPANNERS.  
EXCESSIVE TIGHTENING WILL RESULT IN POINTS CRACKING**

ITEM NO.	PART NO.	DESCRIPTION	QTY.
1	SW191	Subsoiler Leg	1
2	SW194M	Cast Subsoiler Point	1
3	SWM1665	M16 x 65 Bolt	1
4	SWM16004	M16 Nylock Nut	1
5	SW192	25mm Weld on Leg Bottom	1

DO NOT SCALE DRAWING

MACHINE/COMPONENT: **Mounted Subsoiler**

TITLE:

**Leg and Point Assembly**



Drawings and design information found herein remain the sole property of Sumo UK Ltd. Reproductions may only be made with the permission of the owner.

SCALE 1:6

REVISION:

DATE: 7/12/12

INITIAL: TW

## 6.4 Packer Bearing Assembly

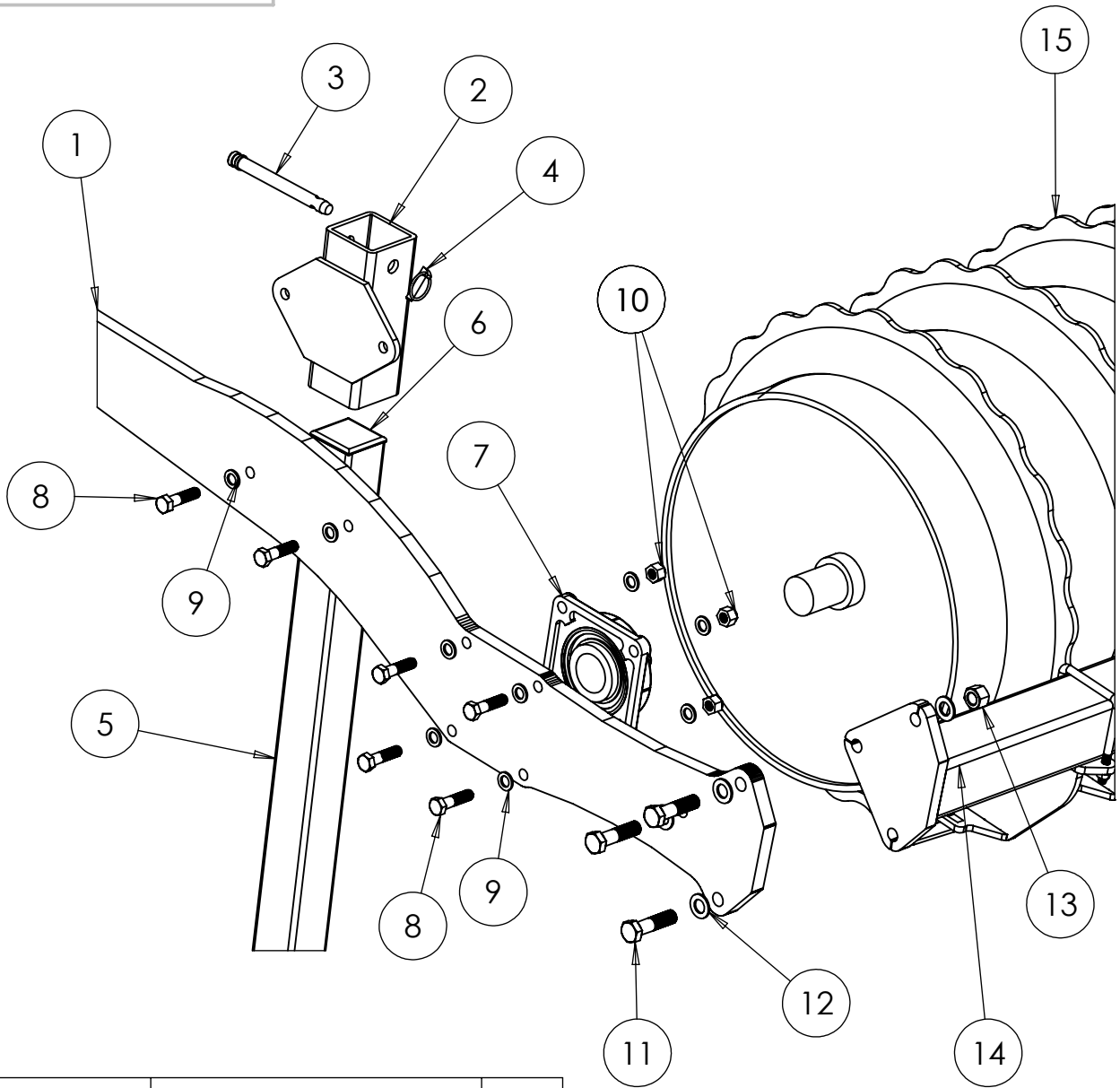

ITEM NO.	PART NO.	DESCRIPTION	QTY.
1	SW248	Subsoiler Packer Arm	1
2	SW112	Stand Holder	1
3	SW118	Stand Pin	1
4	SWB105	Lynch Pin	1
5	SW117	Subsoiler Stand	1
6	SWB144	80mm Rubber Stand Cap	1
7	SWB104	Packer Bearing	1
8	SWM1665	M16x65 Bolt	6
9	SWM16001	M16 Washer	12
10	SWM12004	M12 Nylock Nut	6
11	SWM2070	M20x70 Bolt	3
12	SWM20001	M20 Washer	6
13	SWM20004	M20 Nylock Nut	3
14	SW252	3 Leg Subsoiler Scraper Bar	1
	SW1201	4 Leg Subsoiler Scraper Bar	1
	SW253	5 Leg Subsoiler Scraper Bar	1
15	SW255	3 Leg Subsoiler Packer	1
	SW1200	4 Leg Subsoiler Packer	1
	SW256	5 Leg Subsoiler Packer	1

DO NOT SCALE DRAWING

MACHINE/COMPONENT:

Mounted Subsoiler

TITLE:

Packer Bearing Assembly



Drawings and design information found herein remain the sole property of Sumo UK Ltd. Reproductions may only be made with the permission of the owner.

SCALE 1:10

REVISION:

DATE: 10/12/12

INITIAL: TW

## 6.5 Packer Depth Control

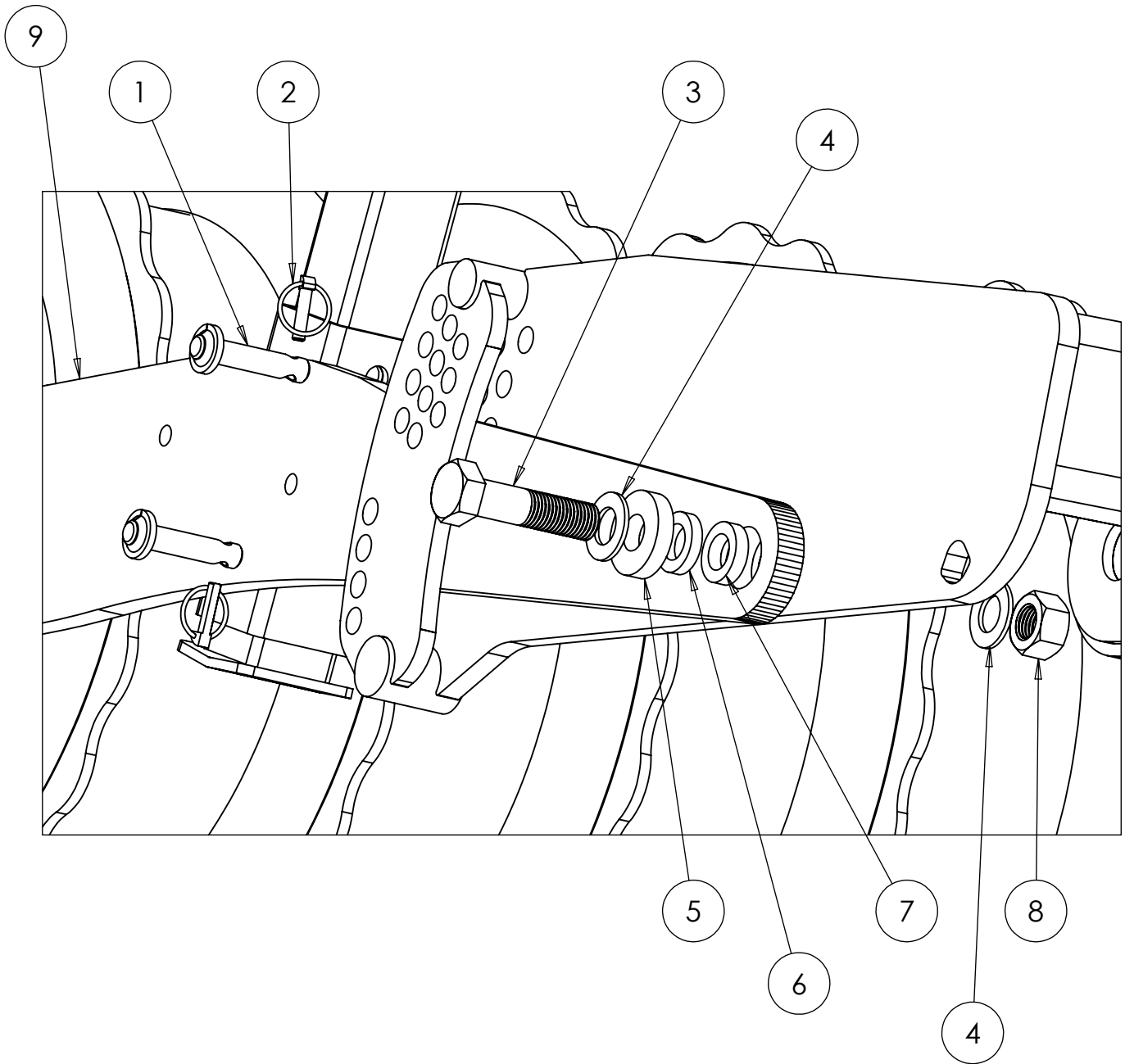

ITEM NO.	PART NO.	DESCRIPTION	QTY.
1	SW130	Packer Depth Pin	2
2	SWB105	Lynch Pin	2
3	SWM30110	M30 x 110 Bolt	1
4	SWM30001	M30 Washer	2
5	SW129	15mm Large Spacer	1
6	SW126	10mm Small Spacer	1
7	SW125	12mm Small Spacer	1
8	SWM30004	M30 Nylock Nut	1
9	SW248	Subsoiler Packer Arm	1

DO NOT SCALE DRAWING

MACHINE/COMPONENT:

Mounted Subsoiler

TITLE:

Packer Depth Control



Drawings and design information found herein remain the sole property of Sumo UK Ltd. Reproductions may only be made with the permission of the owner.

SCALE 1:5

REVISION:

DATE: 7/12/12

INITIAL: TW

## 6.6 Scraper Assembly

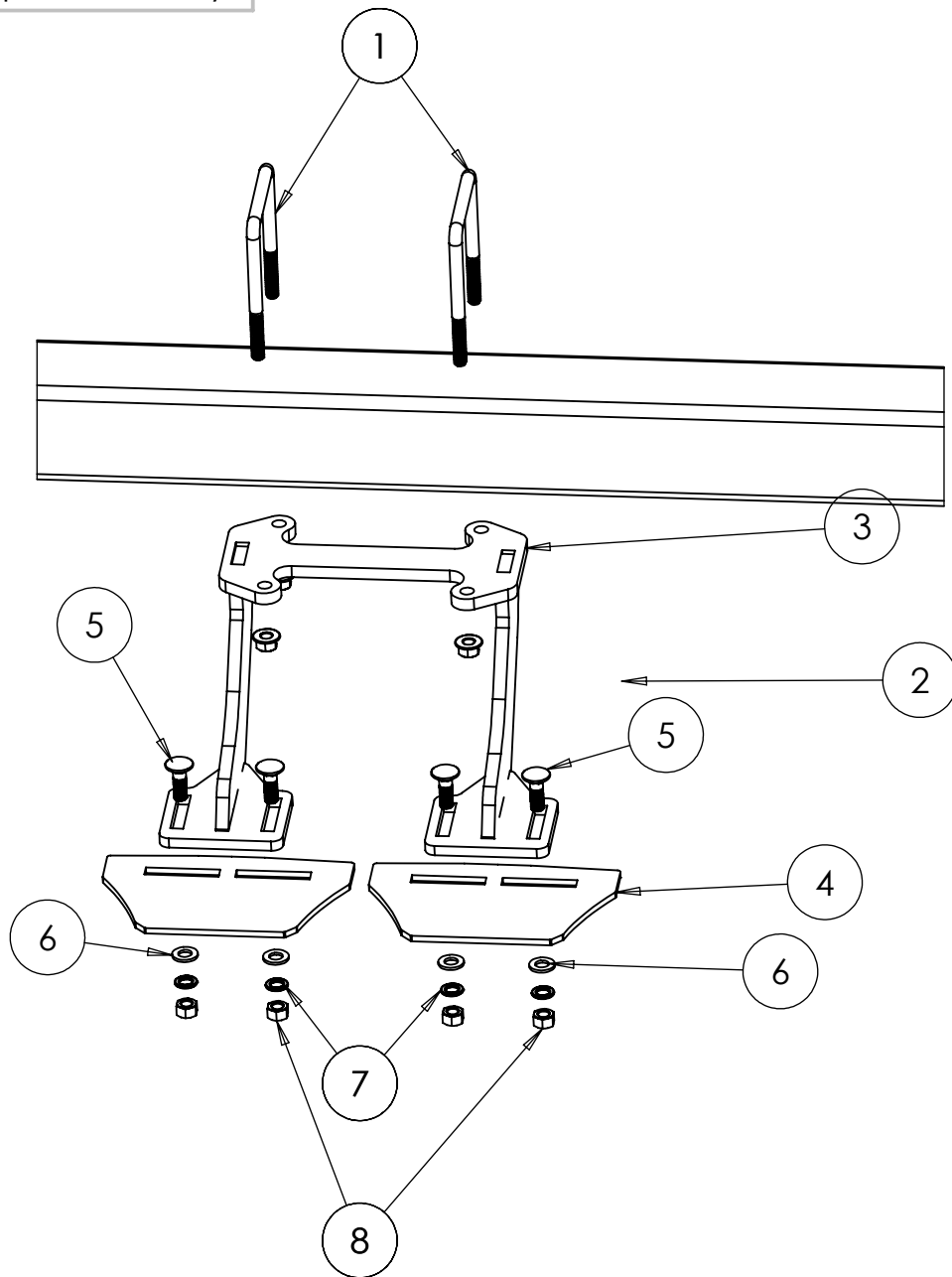

ITEM NO.	PART NO.	DESCRIPTION	QTY.
1	SWM12100UB	M12x100 U Bolt	2
2	SWM12005	M12 Flanged Nut	4
3	SW961	Scraper Hanger	1
4	SW651	Scraper	2
5	SWM1235CHSQ	M12x35 Cup Head Square	4
6	SWM12001	M12 Washer	4
7	SWM12002	M12 Spring Washer	4
8	SWM12003	M12 Plain Nut	4
9	SW1003	Triple Scraper Hanger (not shown)	1

DO NOT SCALE DRAWING

MACHINE/COMPONENT: Mounted Subsoiler

TITLE:

# Scraper Assembly



Drawings and design information found herein remain the sole property of Sumo UK Ltd. Reproductions may only be made with the permission of the owner.

SCALE 1:7

REVISION:

DATE: 10/12/12

INITIAL: TW

## 6.7 Light Assembly

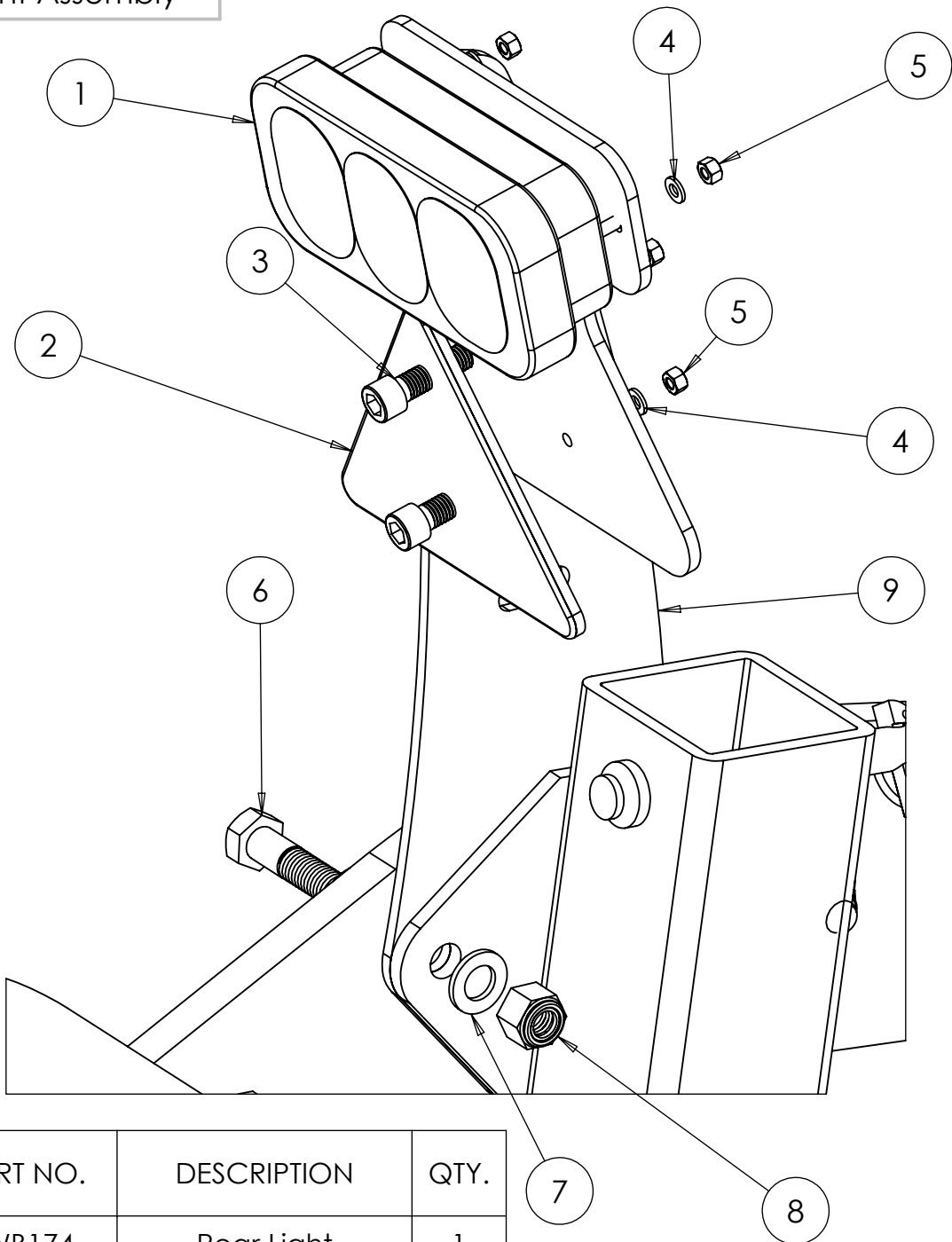

ITEM NO.	PART NO.	DESCRIPTION	QTY.
1	SWB174	Rear Light	1
2	SWB162	Warning Triangle	1
3	SWM6020AKH	M6 x 20 Allan Key Head Bolt	2
4	SWM6001	M6 Washer	4
5	SWM6004	M6 Plain Nut	4
6	SWM1660	M16 x 60 Bolt	2
7	SWM16001	M16 Washer	4
8	SWM16004	M16 nylock Nut	2
9	SW761/SW760	Light Bracket L/H & R/H (not shown)	1
10	SWB175	Wiring Loom (not shown)	1

DO NOT SCALE DRAWING

MACHINE/COMPONENT:

Mounted Subsoiler

TITLE:

Light Assembly



Drawings and design information found herein remain the sole property of Sumo UK Ltd. Reproductions may only be made with the permission of the owner.

SCALE 1:3

REVISION:

DATE: 29/10/12

INITIAL: TW

## 6.8 Main Frame

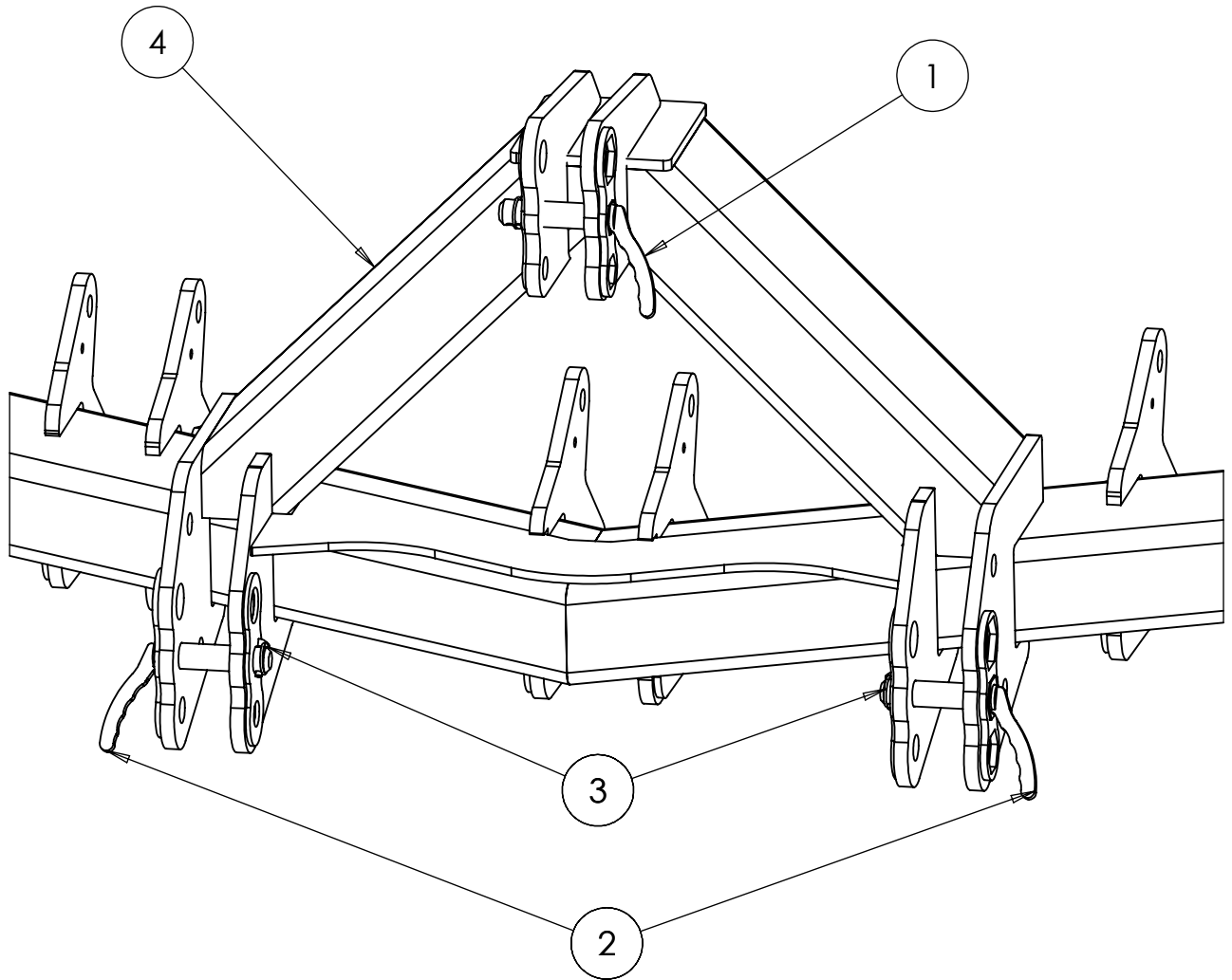

ITEM NO.	PART NO.	DESCRIPTION	QTY.
1	SW627ext	Top Link Pin	1
2	SW626ext	Bottom Link Pin	2
3	SWB107	Safety Lynch Pin	3
4	SW249	3 Leg Shear Bar Main Frame	1
	SW1202	4 Leg Shear Bar Main Frame	1
	SW250	5 Leg Shear Bar Main Frame	1
	SW401	3 Leg Auto Reset Main Frame	1
	SW1203	4 Leg Auto Reset Main Frame	1
	SW402	5 Leg Auto Reset Main Frame	1

DO NOT SCALE DRAWING

MACHINE/COMPONENT: **Mounted Subsoiler**

TITLE:

**Main Frame**



Drawings and design information found herein remain the sole property of Sumo UK Ltd. Reproductions may only be made with the permission of the owner.

SCALE 1:10

REVISION:

DATE: 10/12/12

INITIAL: TW

## 6.9 3 Leg Hydraulics

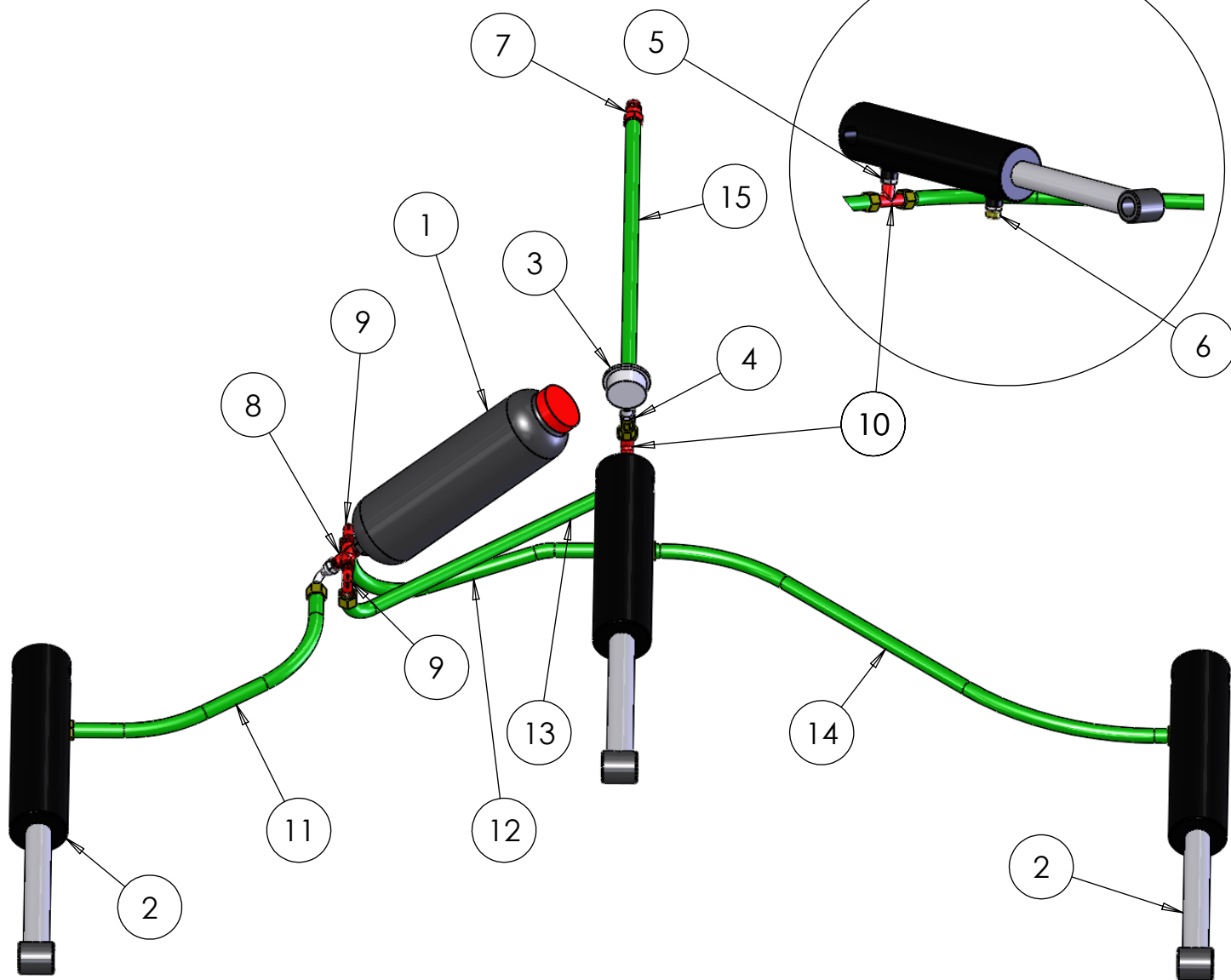

ITEM NO.	PART NO.	DESCRIPTION	QTY.
1	SWH330 (50)	3L Accumulator	1
2	SWH125	705/2 Ram	3
3	SWH181	Pressure Gauge	1
4	SWH180	Flow Control Valve	1
5	SWH303	3/8m - 12Lm Adaptor	1
6	SWH177	3/8 Filtered Breather	3
7	SWH147	Quick Release Coupling	1
8	SWH199	15L Cross	1
9	SWH368	15L 90	2
10	SWH156	12L T	1
11	SWH404	3/8 hose 3/8 Banjo/15L90F-3/8 hose tail	1
12	SWH405	3/8 hose 15LSF/ 12LSF	1
13	SWH406	3/8 hose 12LSF/ 3/8 Banjo	1
14	SWH407	3/8 hose 15LSF/ 12L45	1
15	SWH373	3/8 hose 12LSF/ 1/2M 1500mm	1

DO NOT SCALE DRAWING

MACHINE/COMPONENT:

Mounted Subsoiler

TITLE:

3 Leg Hydraulics



Drawings and design information found herein remain the sole property of Sumo UK Ltd. Reproductions may only be made with the permission of the owner.

SCALE 1:10

REVISION:

DATE: 14/12/12

INITIAL: TW

## 6.10 4 Leg Hydraulics

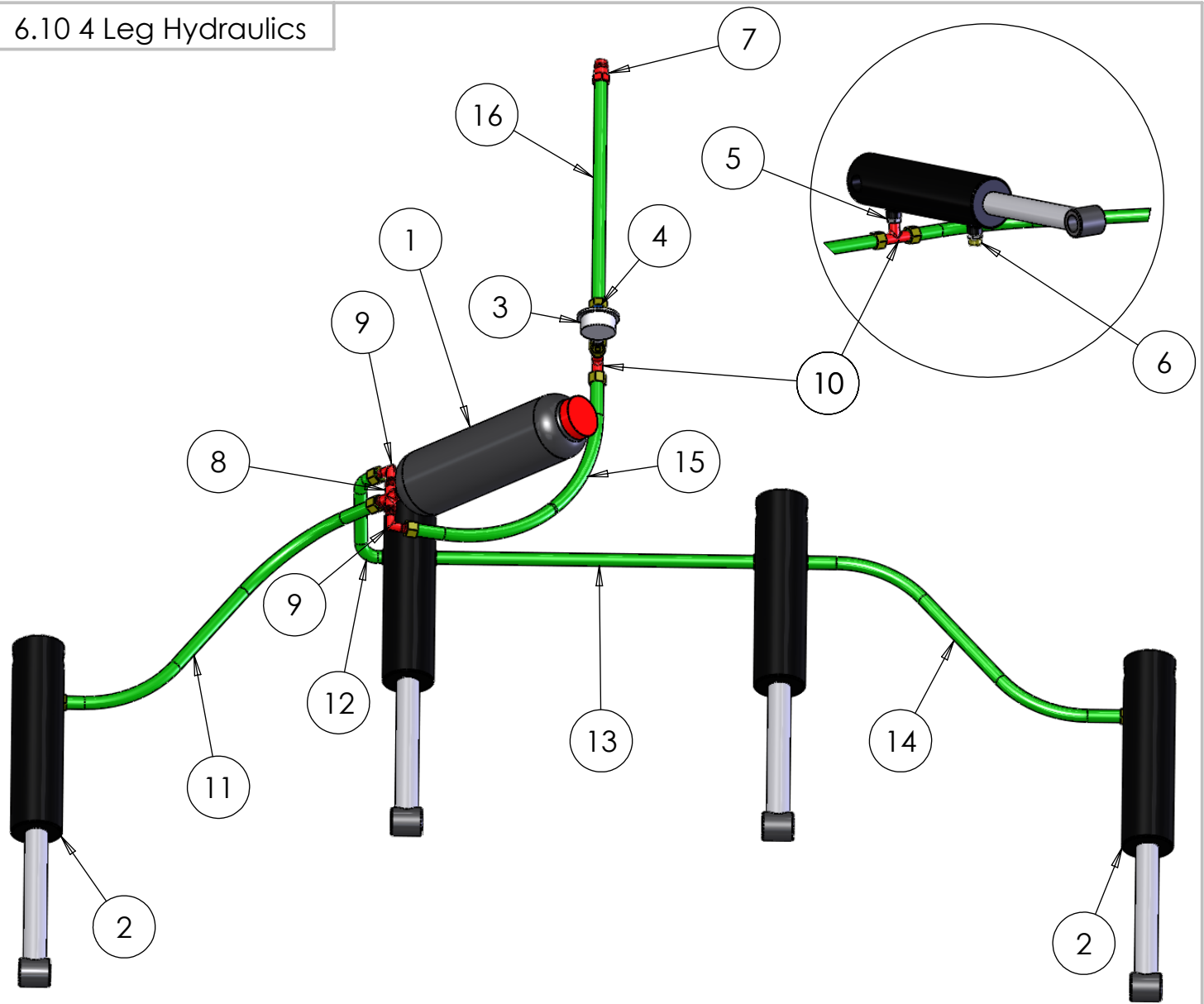

ITEM NO.	PART NO.	DESCRIPTION	QTY.
1	SWH330 (50)	3L Accumulator	1
2	SWH125	705/2 Ram	4
3	SWH181	Pressure Gauge	1
4	SWH180	Flow Control Valve	1
5	SWH303	3/8m - 12Lm Adaptor	2
6	SWH177	3/8 Filtered Breather	4
7	SWH147	Quick Release Coupling	1
8	SWH199	15L Cross	1
9	SWH368	15L 90	2
10	SWH156	12L T	3
11	SWH408	3/8 hose 3/8 banjo/ 15LSF	1
12	SWH409	3/8 hose 15LSF/ 12LSF	1
13	SWH410	3/8 hose 12LSF/ 12LSF	1
14	SWH411	3/8 hose 12LSF/ 3/8 Banjo	1
15	SWH412	3/8 hose 12LSF/ 15LSF	1
16	SWH373	3/8 hose 12LSF/ 1/2M 150mm	1

DO NOT SCALE DRAWING

MACHINE/COMPONENT:

Mounted Subsoiler

TITLE:

4 Leg Hydraulics



Drawings and design information found herein remain the sole property of Sumo UK Ltd. Reproductions may only be made with the permission of the owner.

SCALE 1:11

REVISION:

DATE: 14/12/12

INITIAL: TW

## 6.11 5 Leg Hydraulics

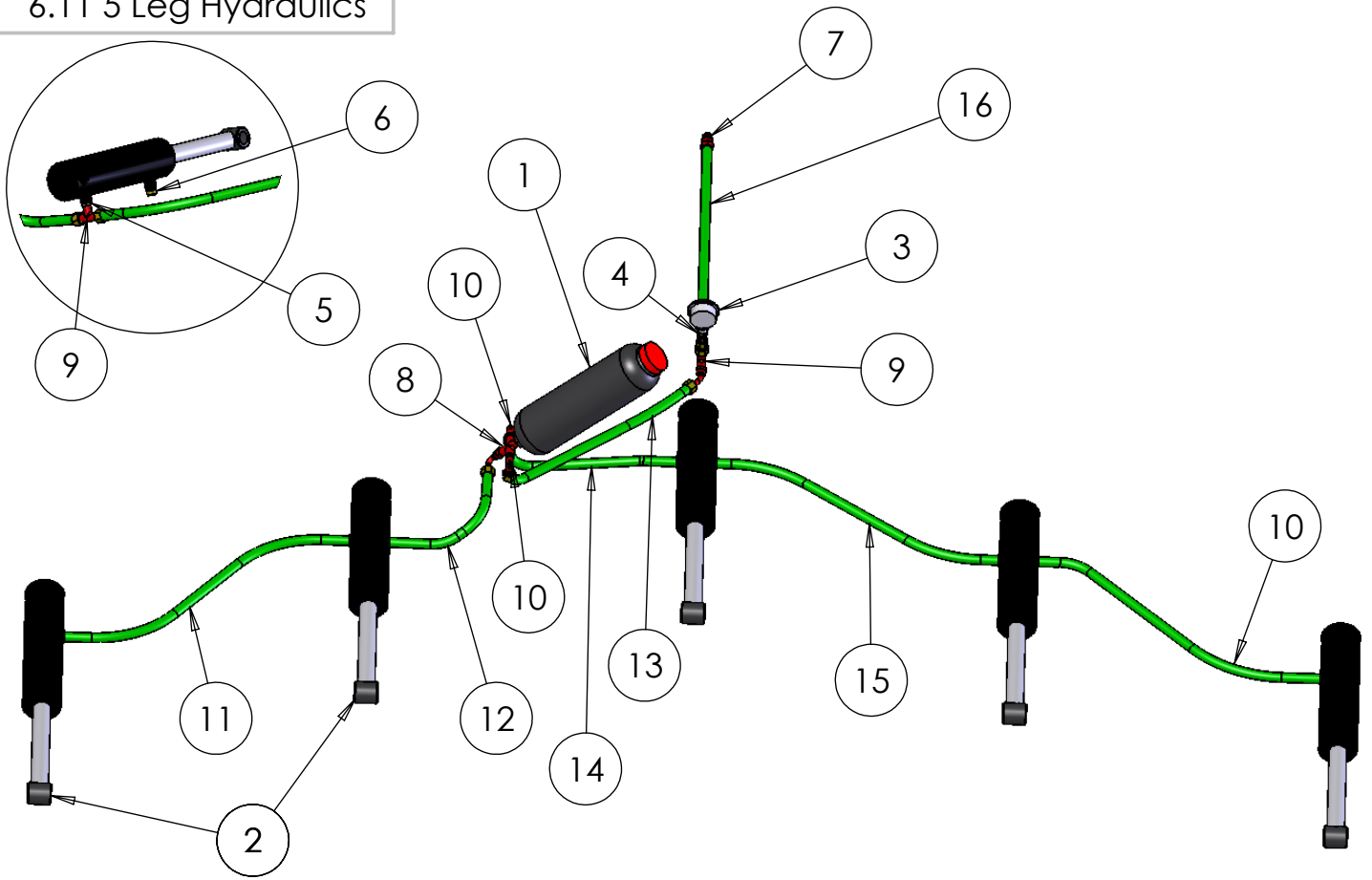

ITEM NO.	PART NO.	DESCRIPTION	QTY.
1	SWH330 (50)	3L Accumulator	1
2	SWH125	705/2 Ram	5
3	SWH181	Pressure Gauge	1
4	SWH180	Flow Control Valve	1
5	SWH303	3/8m - 12Lm Adaptor	3
6	SWH177	3/8 Filtered Breather	5
7	SWH147	Quick Release Coupling	1
8	SWH199	15L Cross	1
9	SWH156	12L T	4
10	SWH368	15L 90	2
11	SWH399	3/8 hose 3/8 Banjo/ 12LSF 740mm	2
12	SWH400	3/8 hose 12LSF/ 15L90F-3/8 hose tail 325mm	1
13	SWH401	3/8 hose 15LSF/ 12L45F 585mm	1
14	SWH402	3/8 hose 15LSF/ 12LSF 560mm	1
15	SWH403	3/8 hose 12LSF/ 12LSF 655mm	1
16	SWH373	3/8 hose 12LSF/ 1/2M 1500mm	1

DO NOT SCALE DRAWING

MACHINE/COMPONENT: Mounted Subsoiler

TITLE:

# 5 Leg Hydraulics



Drawings and design information found herein remain the sole property of Sumo UK Ltd. Reproductions may only be made with the permission of the owner.

SCALE 1:17

REVISION:

DATE: 13/12/12

INITIAL: TW

# 6.12 7 Leg Hydraulics

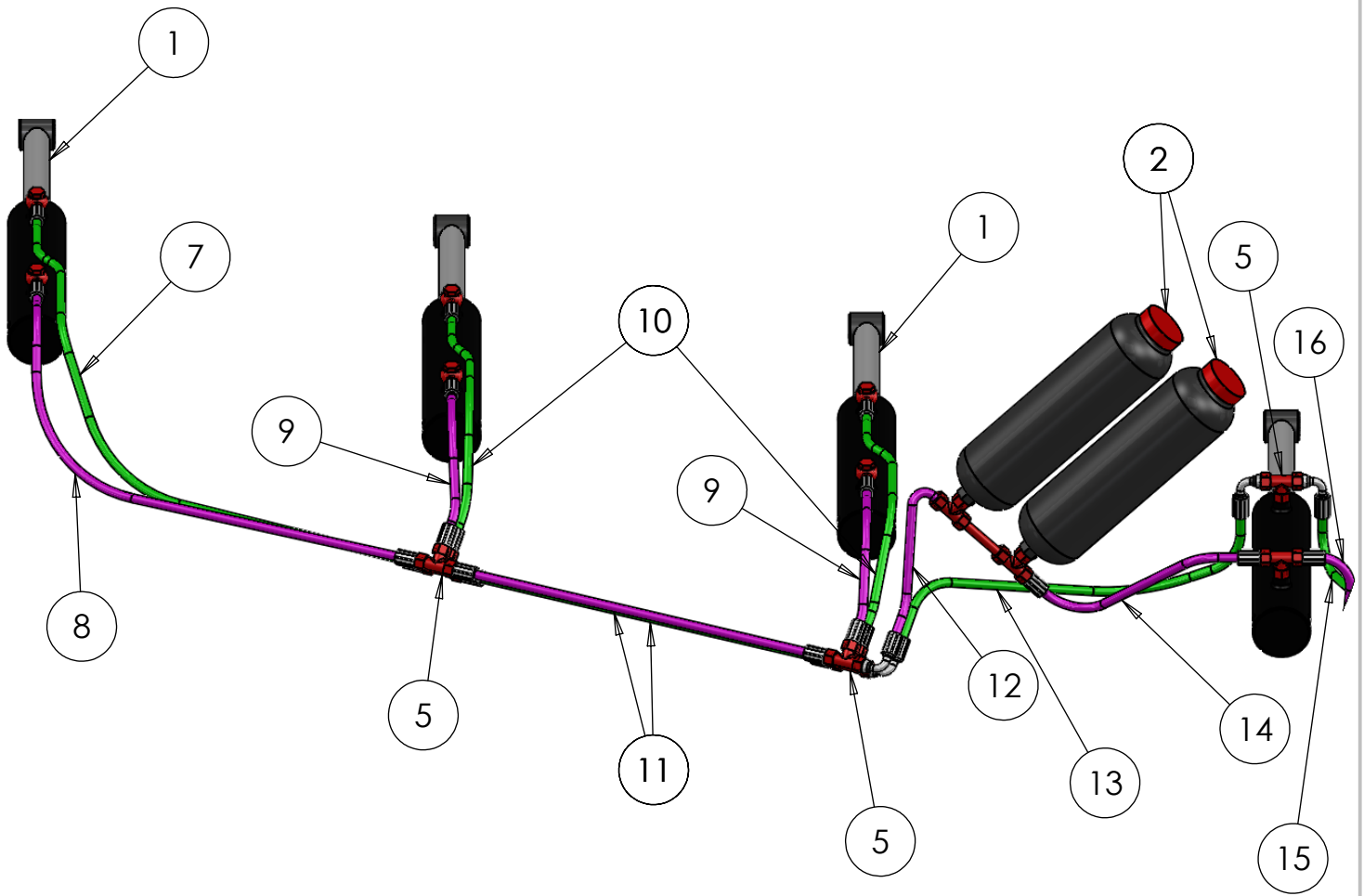

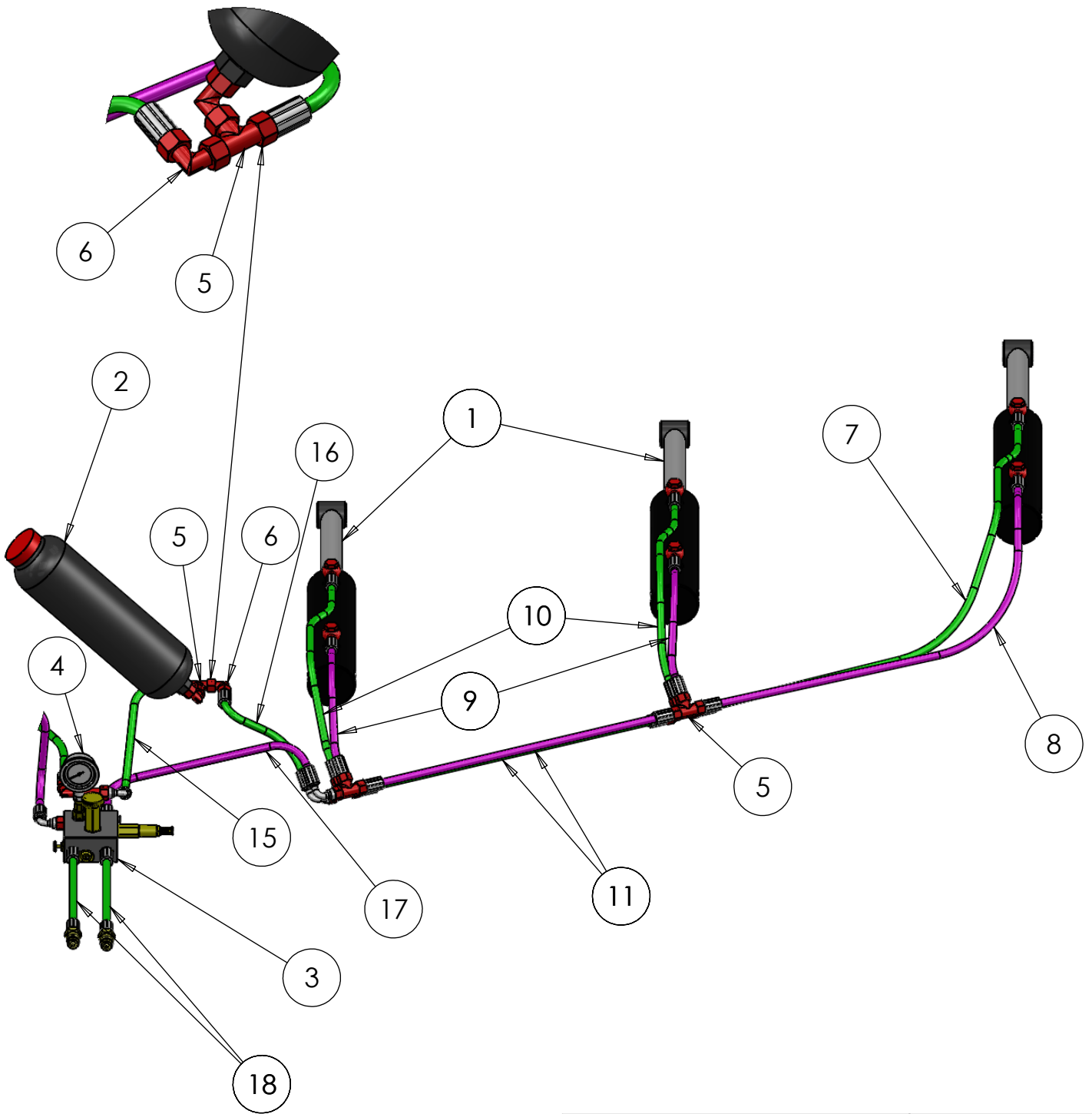

DO NOT SCALE DRAWING

MACHINE/COMPONENT: Mounted Subsoiler

TITLE:  
7 Leg Hydraulics



Drawings and design information found herein remain the sole property of Sumo UK Ltd. Reproductions may only be made with the permission of the owner.

SCALE: 1:11

REVISION:

DATE: 21/10/14

INITIAL: TW

6.12 7 Leg Hydraulics

ITEM NO.	PART NO.	DESCRIPTION	QTY.
1	SWH125	705/2 Ram	7
2	SWH330	3L Accumulator	3
3	SWH298	Vavle Block	1
4	SWH181	Pressure Gauge	1
5	SWH156	12L Tee	15
6	SWH265	12L 90	2
7	SWH552	3/8 Hose 3/8 Banjo / 12LST @ 1190mm	2
8	SWH553	3/8 Hose 3/8 Banjo / 12LST @ 960mm	2
9	SWH554	3/8 Hose 3/8 Banjo / 12LST @ 320mm	4
10	SWH555	3/8 Hose 3/8 Banjo / 12LST @ 530mm	4
11	SWH556	3/8 Hose 3/8 Banjo / 12LST @ 620mm	4
12	SWH557	3/8 Hose 15LSW90 / 12LSW90 @ 220mm	1
13	SWH558	3/8 Hose 12LSW90 / 12LSW90 @ 900mm	1
14	SWH559	3/8 Hose 12LST / 15LST @ 500mm	1
15	SWH560	3/8 Hose 12LSW90 / 12LST @ 500mm	2
16	SWH561	3/8 Hose 12LSW90 / 12LST @ 300mm	2
17	SWH562	3/8 Hose 12LSW90 / 12LSW90 @ 900mm	1
18	SWH373	3/8 Hose 12LST / 1/2M @ 1500mm	2
19	SWH147	Quick Release Coupling	2

DO NOT SCALE DRAWING

MACHINE/COMPONENT:

Mounted Subsoiler

TITLE:

7 Leg Hydraulics



Drawings and design information found herein remain the sole property of Sumo UK Ltd. Reproductions may only be made with the permission of the owner.



SCALE 1:11

REVISION:

DATE: 21/10/14

INITIAL: TW

## 6.13 Stickers and Paint

Sticker	Description	Quantity	Part No.
	<p>Big Sumo horizontal sticker 450 x 125mm</p>	<p>4</p>	<p>SWB125</p>
	<p>Big Union Jack sticker 150 x 100mm</p>	<p>3</p>	<p>SWB127</p>
	<p>Small Sumo Red and White Sticker</p>	<p>2</p>	<p>SWB199</p>
<p>Touch up paint</p>	<p>Sumo Red</p>	<p>1/2 litre</p>	<p>SWB131</p>
	<p>Sumo Black</p>	<p>1/2 litre</p>	<p>SWB132</p>