

# **SUMO**

# **QUATRO**



4.0m & 6.0m machines

## **2014 Operator Manual And Parts List**



1.0 Registration

**To activate your SUMO Warranty**, you must complete this page and send it back to us at:

Sumo UK Ltd  
Redgates  
Melbourne  
York  
YO42 4RG  
Tel. 01759 319900  
Fax. 01759 319901

**(NO REGISTRATION = NO WARRANTY)**

SUMO SERIAL No:

For your own records.

(Serial plate on side of headstock)



**Sumo Quatro Registration Document**

NAME:

ADDRESS:

Postcode:

Telephone Number:

DATE:

SUMO SERIAL No.

(Serial plate on side of headstock)

DEALERSHIP  
NAME AND  
BRANCH:

COMMENTS:



**In order to obtain your free pair of Sumo overalls and baseball cap** please fill in this form and send back to us at:

Sumo UK Ltd  
Redgates  
Melbourne  
York  
YO42 4RG  
Tel. 01759 319900  
Fax. 01759 319901



SUMO SERIAL No:

Overall size:  
tick where applicable

Small (38 chest)	
Medium (42 chest)	
Large (46 chest)	
Extra large (50 chest)	
XX Large (54 chest)	
XXX Large (58 chest)	

NAME:

ADDRESS:



## **2.0 Summary**

The SUMO Quatro, a unique one pass soil conditioning machine designed and manufactured in Britain, comprising as its name suggests of four elements, each of these tuned to comprehensively create the finish required. Three of the four elements are controlled using the machines electro hydraulics, therefore meaning that the Quatro can be run in various configurations.

### **Firstly**

A double row of 500mm concave discs, mounted in pairs on independently suspended arms giving a shock proof durable system with quality low maintenance triple sealed taper roller bearings. Double mounting gives unrivalled performance when working in adverse conditions. The hydraulically adjustable front discs mean that disc working depth can be changed to ensure the machine is used to its full potential.

### **Secondly**

The ultra low draught auto reset protected Subsoiler legs are mounted in a staggered pattern on a heavy duty toolbar, adjusting to a maximum depth of 400mm (at the point) via pins. Due to the design of the legs and their mounting, when a leg is obstructed, the auto reset ram allows the leg to trip. Both rows of legs trip in a fashion which allows the point to come clear of the ground and to pass by the obstacle. These legs feature quick change points and shins.

### **Thirdly**

A repeat bank of double row discs to create a fine tilth.

### **Finally**

The patented Multipacker is uniquely designed to fulfil a number of criteria, comprising, 609mm x 10mm tube mounted on heavy duty quality bearings fitted with notched cutting/ drive rings to keep turning in arduous conditions, giving a total diameter of 800mm. The ring shoulders feature a convex shape adjacent to the barrel, creating consolidation and cracking even on the top of the ridge. All these features make a packer which presses and firms to a higher quality with a lower power requirement than any other packer available.

Before using the SUMO Quatro it is absolutely necessary that you read this Operators Manual and Safety Instructions attentively.

Specifications, descriptions and illustrations in this brochure are accurate, as known, at the time of publication but may be subject to change.



# Table of Contents

- 1.0 Registration
- 2.0 Summary
- 3.0 Safety
  
- 4.0 Operation and adjustments
  - 4.1 Operating
  - 4.2 Adjustments
  - 4.3 Auto-Reset legs
- 5.0 Maintenance
  - 5.1 Spares
  - 5.2 Winter storage
- 6.0 Parts and Assembly
  - 6.1 Twin disc unit
  - 6.2 Single disc unit
  - 6.3 Active soil retainer
  - 6.4 Cast leg socket
  - 6.5 Leg assembly Auto-Reset
  - 6.6 Packer, scrapers and bearings assembly
  - 6.7 Drawbar assembly 6m
  - 6.8 Drawbar assembly 4m
  - 6.9 Drawbar knuckle joint
  - 7.0 Disc hydraulic ram
  - 7.1 Wheels and brakes 6m
  - 7.2 Wheels and brakes 4m
  - 7.3 Leg hydraulic circuit
  - 7.3 Leg hydraulic circuit continued
  - 7.4 6m & 4m Wing hydraulic circuit
  - 7.5 Light and bracket
  - 7.6 Stickers and paint

### **3.0 Safety**

This manual contains basic advice which should be observed during setting-up, operation and maintenance. Therefore, this operating manual must be read by the personnel concerned prior to starting up, using the machine and be available at all times.

If safety instructions are not complied with, then this can lead to the risk of injury to yourself and others as well as damage to the environment or the machine. Non-compliance to the safety instructions can also lead to claims for damages becoming invalid.

#### **3.1 Qualification and Training**

- Ensure that only reliable, authorized personnel work on or with the machine. Statutory minimum age limits must be observed.
- Employ only trained or instructed staff; the individual responsibilities of the personnel concerning operation, setting up, maintenance and repair must be clearly established.
- Define the machine operators' responsibilities – also with regard to observing traffic regulations. The operator must have the authority to refuse any instructions issued by third parties, which contravene safety.
- Persons undergoing training or instruction or taking part in a general training course should not be allowed to work on or with the machine unless they are under the constant supervision of an experienced person.
- The use of spare parts, accessories and ancillary equipment not supplied and/or not approved by SUMO could have detrimental effects to the construction of the SUMO machine or on its functions and hence impair the active and/or passive driving and/or operational safety (accident prevention).
- SUMO shall not be responsible for any damage caused by the use of spare parts, accessories and ancillary equipment not supplied and/or approved by SUMO.
- Conversions of or modifications to the machine may only be carried out after consultation with SUMO.

### **3.2 General safety**

- Warning signs and other notices on the machine provide important information for the safe operation. Observing them will serve your safety.
- Before starting work, make yourself familiar with all the equipment and controls as well as their functions.
- The user should wear close-fitting clothing.
- Keep the machine and in particular the bearings clean to avoid risk of fire.
- Check around the machine before moving off or starting up (watch out for children!). Make sure you have adequate all-round visibility.
- Always match your speed to the local conditions. Avoid sudden turning manoeuvres when driving uphill or downhill or when travelling across a slope.
- Observe the respective regulations when using public roads.
- Take into account the length, the wide overhang, the folded height and the sideways force acting on the machine when turning or negotiating curves.

### **3.3 Special safety instructions**

- Take extreme care when hitching up or unhitching machine to/from the tractor.
- Never allow persons to stand between the tractor and the machine unless the tractor is secured against rolling away by means of parking brake and/or wheel chocks.
- It is forbidden to allow persons to ride on the machine at any time. A safe distance should be maintained from the machine by observers when in work.
- Never stand or work beneath suspended loads.
- Ensure all persons are stood clear of the machine when folding or unfolding.
- When making adjustments to the machines care should be taken not to trap any body parts in moving or pivoting parts.
- When making adjustments to the machine the tractor engine should be switched off to prevent the hydraulics from operating.

## **4.0 Operation and Adjustment**

### **4.1 Operating**

Optimum soil conditioning will occur when the Quatro wing frames are running horizontal (parallel with the ground).

Adding or removing slices from the drawbar ram allows for finite angle adjustment of the working angle. Forward working speed should be governed by the local conditions as well as the finish produced by the Sumo Quatro

### **4.2 Adjustments**

Depth adjustment of the Subsoiler legs is achieved by firstly removing the lynch pin and then the depth pins. The leg can then be lifted or lowered to the required position and then the shear pin and clip should be replaced. The maximum leg depth is 400 mm. The easiest and most accessible way to change the leg depths (if available) is to fold the wings up and slide the legs in or out.

To adjust the disc working depth, the appropriate channel should be selected on the electro hydraulic control box. Operating the tractor hydraulics will then allow adjustments to be made. Slices are also present on the rams to give exact positioning. The disc unit slices, mixes and cultivates the top 50 - 100mm of soil.

### **4.3 Auto-Reset Legs**

The pressure in the hydraulic circuit controlling the auto-reset Subsoiler legs can be altered depending on circumstances and preference up to a maximum of 120 bar. (Exceeding this pressure may result in damage to the machine). The higher the hydraulic pressure, the more resistance the legs have to tripping.

To alter the pressure in the hydraulic circuit:

1. Select the appropriate channel on the electro hydraulic control box.
2. Change line A of the Auto- Reset circuit using the tractor hydraulics.
3. The pressure is set according to the Auto-Reset valve block (mounted on the side of the chassis).  
The large gold/silver knob with lock-off ring can be adjusted in & out.  
Wind in for more resistance. Try one turn at a time.
4. Once a change has been made to the pressure setting, cycle the legs up and down again to set the pressure in the circuit. Even though the pressure is locked in the circuit, this system does remain active in that the legs can be raised up out of work.
5. The tractor hydraulics should be returned to float to relieve any back pressure before commencing work at the new pressure

**DO NOT TIGHTEN POINTS UP WITH AIR RACHETS OR OVER TIGHTEN WITH SPANNERS. EXSESIVE TIGHTENING WILL RESULT IN POINTS CRACKING**



## **5.0 Maintenance**

The packer bearings should be greased with one pump once a week and after washing off.

The disc bearings should be greased until old grease is forced out once a week when in normal use and after washing off.

The condition of the subsoiler legs, the points and the discs should be regularly monitored in order to maintain the most efficient use of the machine.

Wheel studs should be checked that they are tight after the first 10hrs operation and again regularly every week when in use. They should be tightened to a torque setting of 450Nm.

Tyre pressures should be set to 30 PSI and regularly checked

The condition and position of the packer scrapers should also be observed in order to prevent soil building up on the packer. Ensure the scrapers are not touching the packer though, as this will add rolling resistance as well as causing premature wear of the packer.

Grease points requiring one pump every 50 hours are located on rams, wing, hinge, bushes, drawbar hinge bushes front and back, both top and bottom elements. Exposed chrome ram rods should also be greased weekly to prevent these valuable parts from rusting and causing costly oil leaks.

### **5.1 Spares**

When ordering replacement parts please have your serial number, part numbers (listed in Section 8.0) and quantities at hand.

### **5.2 Winter storage**







When machines are to be parked up for the winter period, correct storage techniques are an important part of protecting the machine to ensuring a hassle free season. When the machine has finished work it should be cleaned down and washed off to remove all traces of soil.

Following washing off, the packer bearings should be greased with one pump and the disc bearings should be greased until old grease is forced out. Other grease points are located on all rams, wing hinge bushes and drawbar hinge bushes, and these should receive two or three pumps of grease.

Wheel studs should be checked that they are tight. Tyre pressures should also be checked to ensure there is not a slow puncture before entering storage.

When the machine is parked up a note should be made of what wearing parts require replacing ready for the next seasons work. The wearing parts can then be ordered in time ready for the next season's work in good time to avoid delays when the machine is required earlier than expected!

## 7.6 Stickers and paint

Sticker	Description	Quantity	Part No.
	Big Sumo horizontal sticker	6	SWB125
	Big Quatro sticker	6	SU013
	Big Union Jack sticker 150 x 100mm	4	SWB127
	Vertical Sumo sticker 80 x 295mm	2	SWB128
	Small Union Jack sticker	4	SWB129
	Small Sumo Horizontal Sticker	4	SWB130
Sumo touch - up paint	Sumo Red	1/2 Litre	SWB131
	Sumo Black	1/2 Litre	SWB132

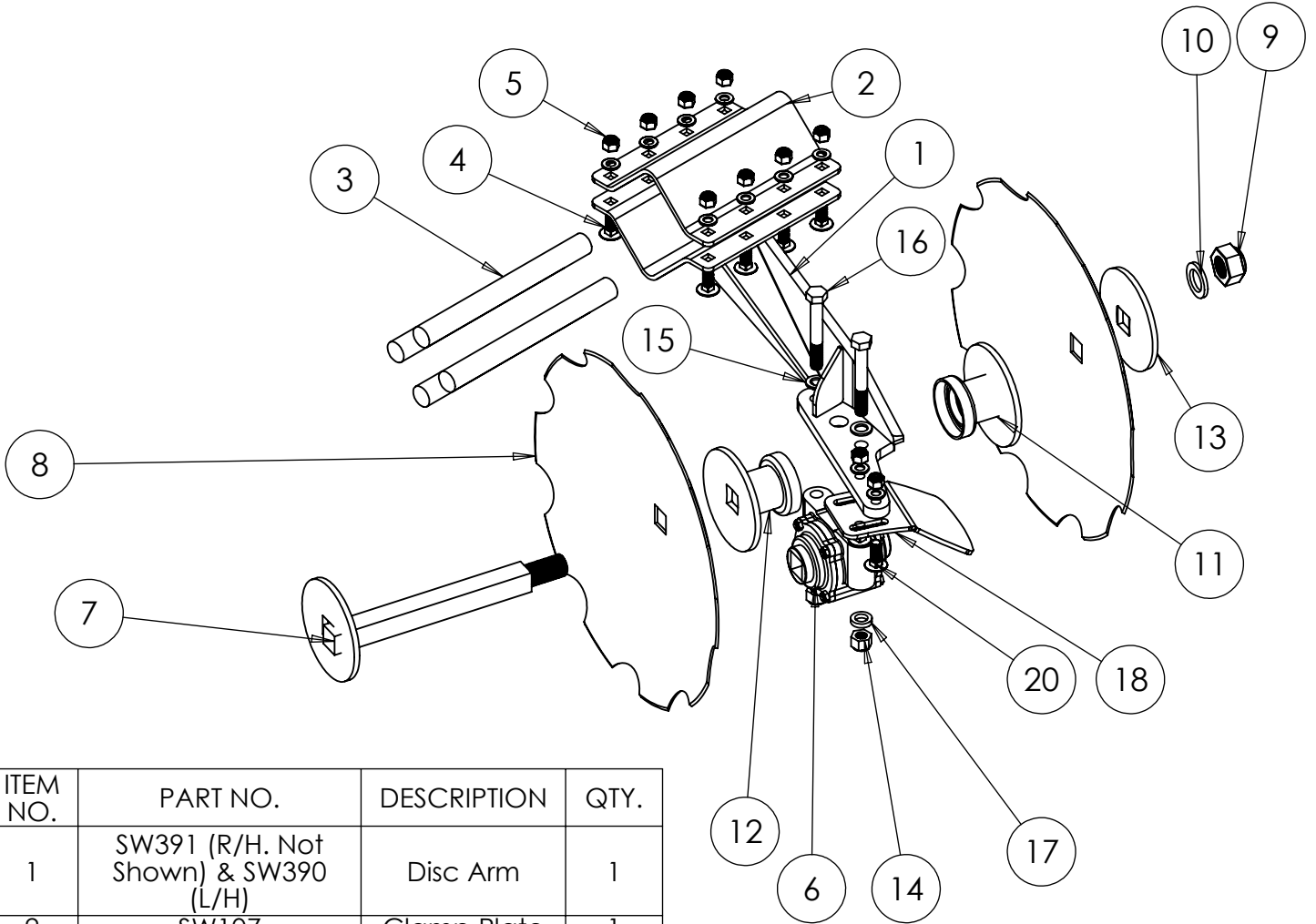

ITEM NO.	PART NO.	DESCRIPTION	QTY.
1	SW391 (R/H. Not Shown) & SW390 (L/H)	Disc Arm	1
2	SW107	Clamp Plate	1
3	SWB103	Rubber	4
4	SWM1235CHSQ	M12 x 35 Cup Head Square	10
5	SWM12005	M12 Flanged Nut	10
6	SWB102	Bearing	1
7	SW101	Twin Disc Axle	1
8	SWB101	20" Scalloped Disc	2
9	SWM3004	M30 Nylock Nut	1
10	SWM30001	M30 Washer	1
11	SW103	Dust Cover and Convexed Disc	1
12	SW102	Dust Cover and Concaved Disc	1
13	SW108	Disc Axle Washer	1
14	SWM16004	M16 Nylock Nut	2
15	SWM16001	M16 Washer	2
16	SWM16120	M16 x 120 Bolt	2
17	SW1153	M16 Washer (Thick)	2
18	SW646	Disc Scraper	1
19	SWB184	18" Scalloped Disc (end of disc row, Not Shown)	1
20	SWM1240CHSQ	M12 x 40 Cup Head Square	2

DO NOT SCALE DRAWING

MACHINE/COMPONENT: **Sumo Quatro**

TITLE: **Twin Disc Unit Assembly**



Drawings and design information found herein remain the sole property of Sumo UK Ltd. Reproductions may only be made with the permission of the owner.

REVISION:
DATE: 09/04/14
INITIAL: TW

## 6.2 Single Disc Unit Assembly

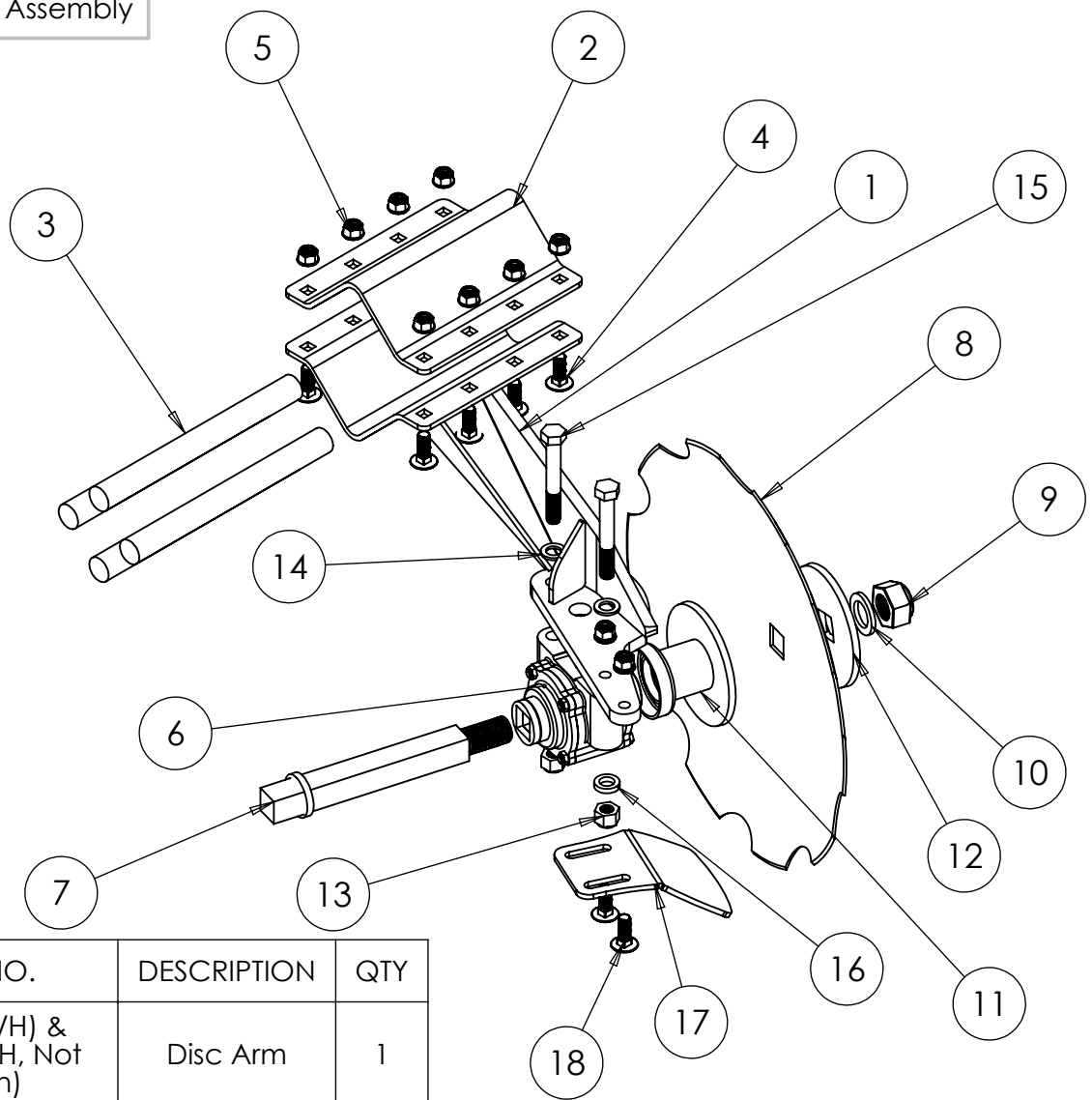

ITEM NO.	PART NO.	DESCRIPTION	QTY
1	SW390 (L/H) & SW391 (R/H, Not Shown)	Disc Arm	1
2	SW107	Clamp Plate	1
3	SWB103	Rubber	4
4	SWM1235CHSQ	M12 x 35 Cup Head Square	10
5	SWM12005	M12 Flanged Nut	10
6	SWB102	Bearing	1
7	SW109	Single Disc Axle	1
8	SWB101	20" Scalloped Disc	1
9	SWM30004	M30 Nylock Nut	1
10	SWM30001	M30 Washer	1
11	SW103	Dust Cover and Convexed Disc	1
12	SW108	Disc Axle Washer	1
13	SWM16004	M16 Nylock Nut	2
14	SWM16001	M16 Washer	2
15	SWM16120	M16 x 120 Bolt	2
16	SW1153	M16 Washer (Thick)	2
17	SW646	Disc Scraper	1
18	SWM1240CHSQ	M12 x 40 Cup Head Square	2

DO NOT SCALE DRAWING

MACHINE/COMPONENT:

Sumo Quatro

TITLE:

Single Disc Unit Assembly



Drawings and design information found herein remain the sole property of Sumo UK Ltd. Reproductions may only be made with the permission of the owner.

REVISION:

DATE: 09/04/14

INITIAL: TW

### 6.3 Active Soil Retainer

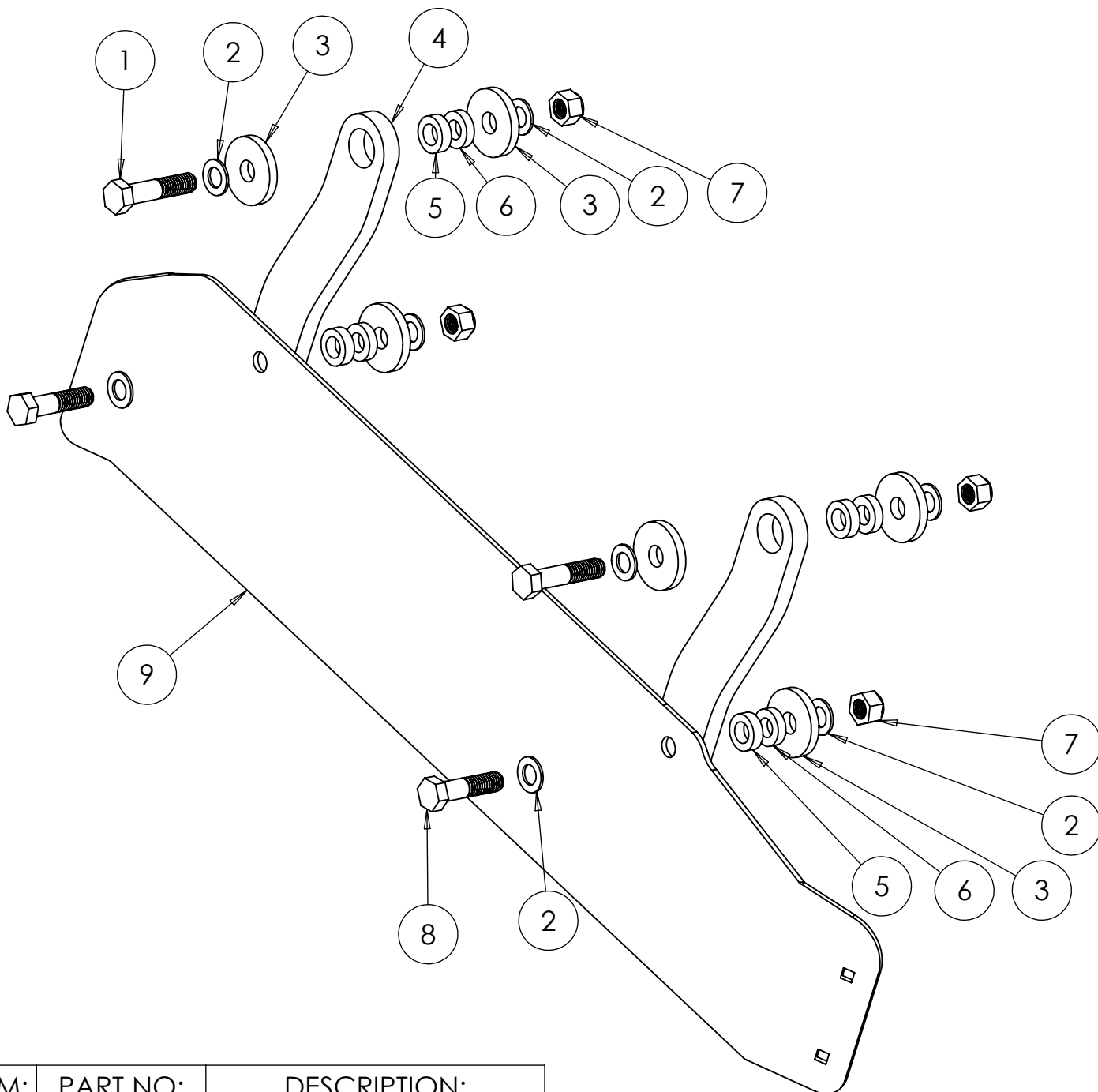

ITEM:	PART NO:	DESCRIPTION:
1	SWM2090	M20 X 90 bolt
2	SWM20001	M20 flat washer
3	SW123	12mm large spacer
4	SW124	Crank arm
5	SW125	12mm spacer sm
6	SW126	10 MM spacer sm
7	SWM20004	M20 nylock nut
8	SWM2080	M20 X 80 bolt
9	SW418	Soil retainer left
	SW419	Soil retainer right (not shown)

DO NOT SCALE DRAWING

MACHINE/COMPONENT:

Sumo Quatro

TITLE:

Active Soil Retainer



Drawings and design information found herein remain the sole property of Sumo UK Ltd. Reproductions may only be made with the permission of the owner.

REVISION:

DATE: 09/04/14

INITIAL: TW

6.4 Auto Reset Assembly

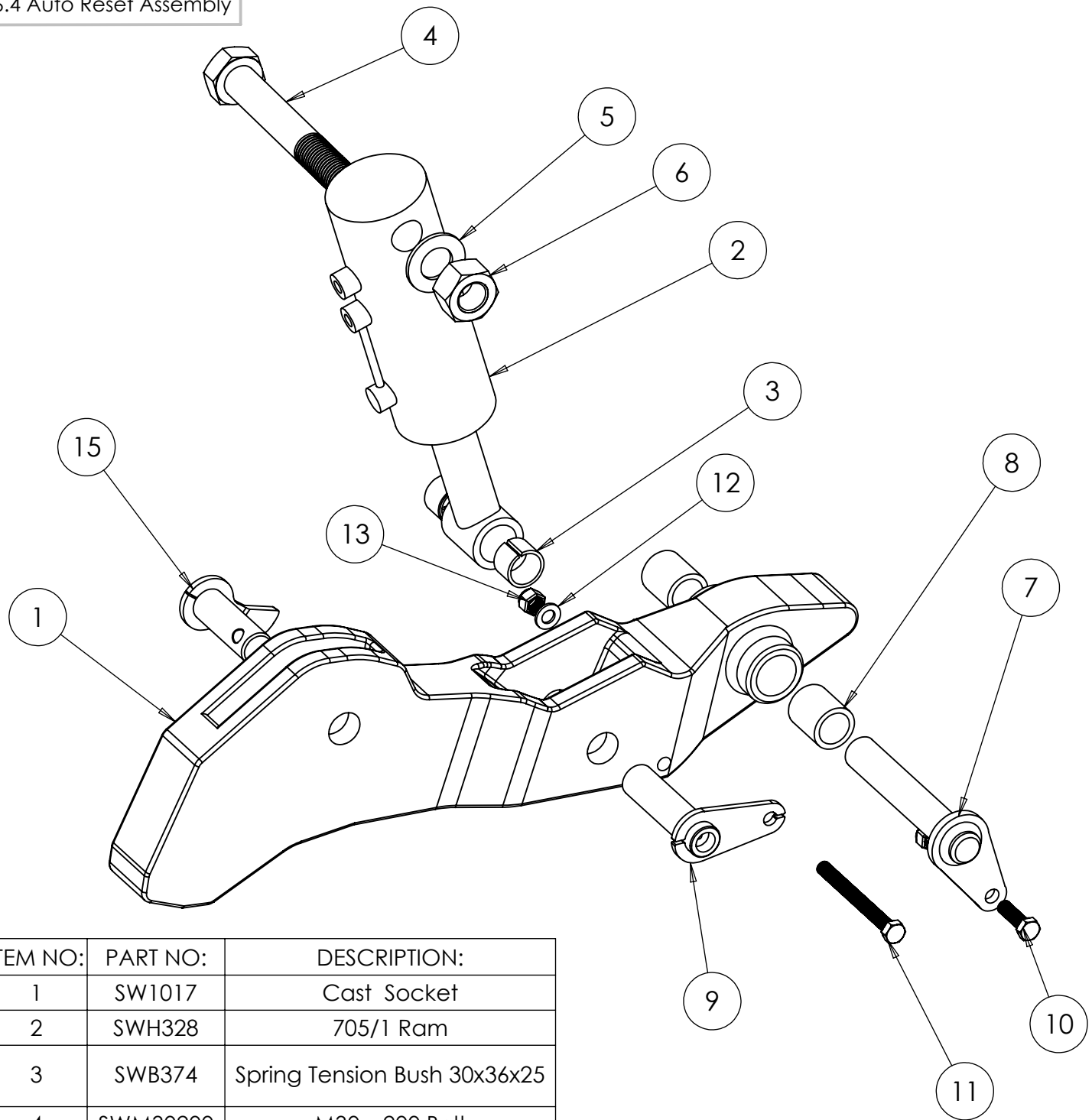

ITEM NO:	PART NO:	DESCRIPTION:
1	SW1017	Cast Socket
2	SWH328	705/1 Ram
3	SWB374	Spring Tension Bush 30x36x25
4	SWM30200	M30 x 200 Bolt
5	SWM30001	M30 Washer
6	SWM30004	M30 Nylock Nut
7	SW183	30mm x 170mm Tabbed Pin
8	SW188	30x40x45mm PB1 Bush
9	SW1192	30mm x 120mm Tabbed Pin c/w Grease Nipple (L/H & R/H)
10	SWM1240	M12 x 40 Bolt
11	SWM12130	M12 x 130 bolt
12	SWM12001	M12 Washer
13	SWM12004	M12 Nylock Nut
14	SWB105	Linch Pin
15	SW451	Leg Depth Pin

DO NOT SCALE DRAWING

MACHINE/COMPONENT: Sumo Quatro

TITLE:

# Auto Reset Assembly



Drawings and design information found herein remain the sole property of Sumo UK Ltd. Reproductions may only be made with the permission of the owner.

REVISION:

DATE: 09/04/14

INITIAL: TW

## 6.5 Leg Assembly

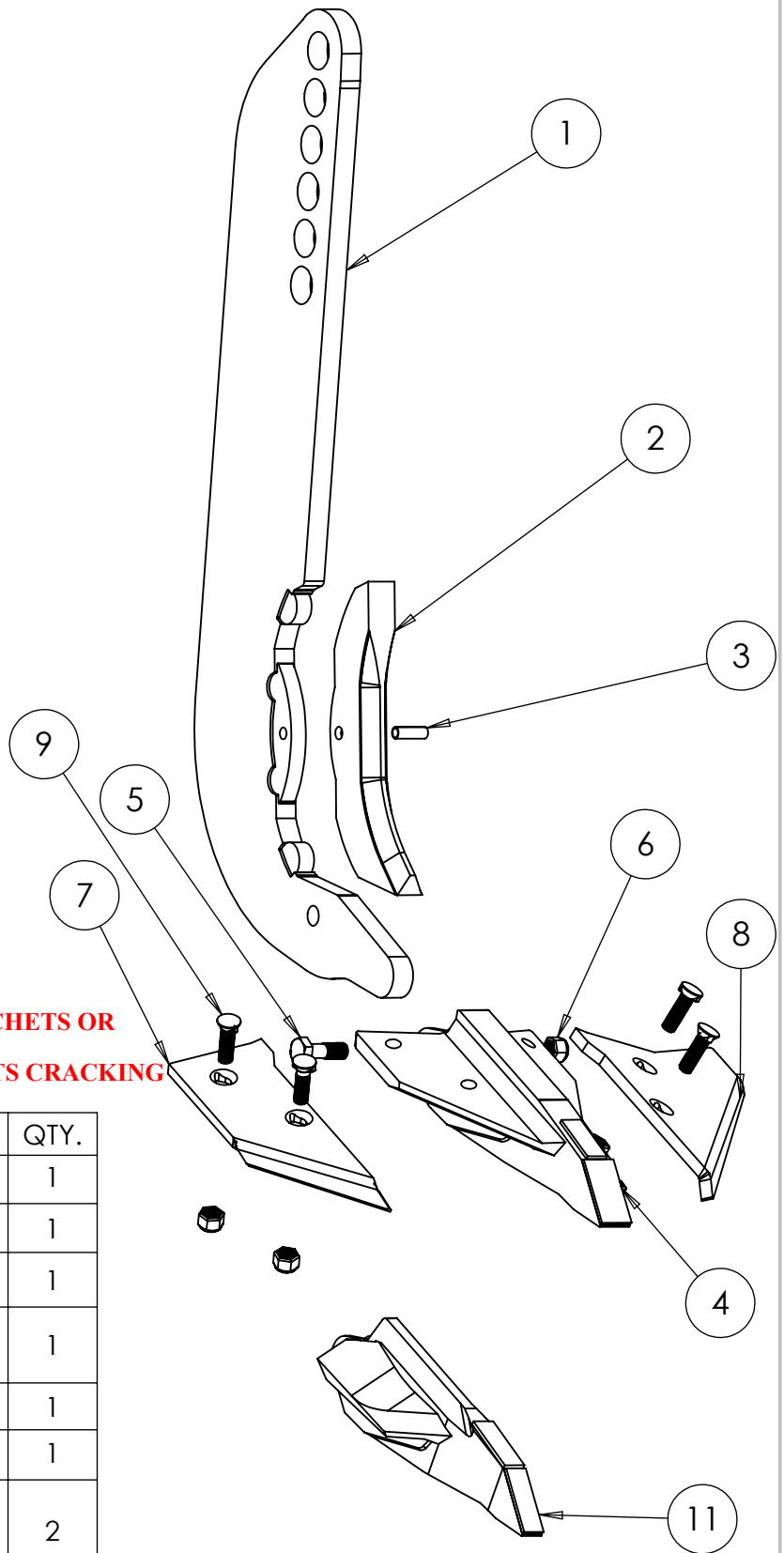
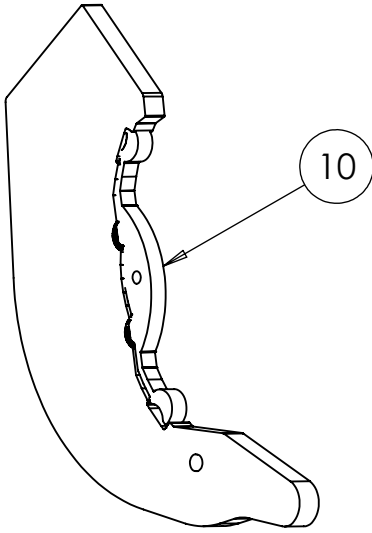

**DO NOT TIGHTEN POINTS UP WITH AIR RACHETS OR OVER TIGHTEN WITH SPANNERS. EXSESIVE TIGHTENING WILL RESULT IN POINTS CRACKING**

ITEM NO.	PART NO.	DESCRIPTION	QTY.
1	SW1046	Trio Leg	1
2	SW1048	Cast Shin	1
3	SWB183	M10 x 30 Roll Pin	1
4	SW1050	Concord Point	1
5	SWM1250	M12 x 50 Bolt	1
6	SWM12004	M12 Nylock Nut	1
7	SWB401/400	4" R/H Wing & L/H Wing (Not Shown)	2
8	SWB366/367	8" L/H Wing & R/H Wing (Not Shown)	2
9	SWM1235TN	M12 x 35 Twin Nibbed Bolt c/w Plain Nut	4
10	SW1047	Trio Weld on Leg Bottom	1
11	SWB441	Low Disturbance Point	1

DO NOT SCALE DRAWING

MACHINE/COMPONENT:

Sumo Quatro

TITLE:

Leg Assembly



Drawings and design information found herein remain the sole property of Sumo UK Ltd. Reproductions may only be made with the permission of the owner.

REVISION:

DATE: 09/04/14

INITIAL: TW

## 6.6 Packer, Scraper and Bearing Assembly

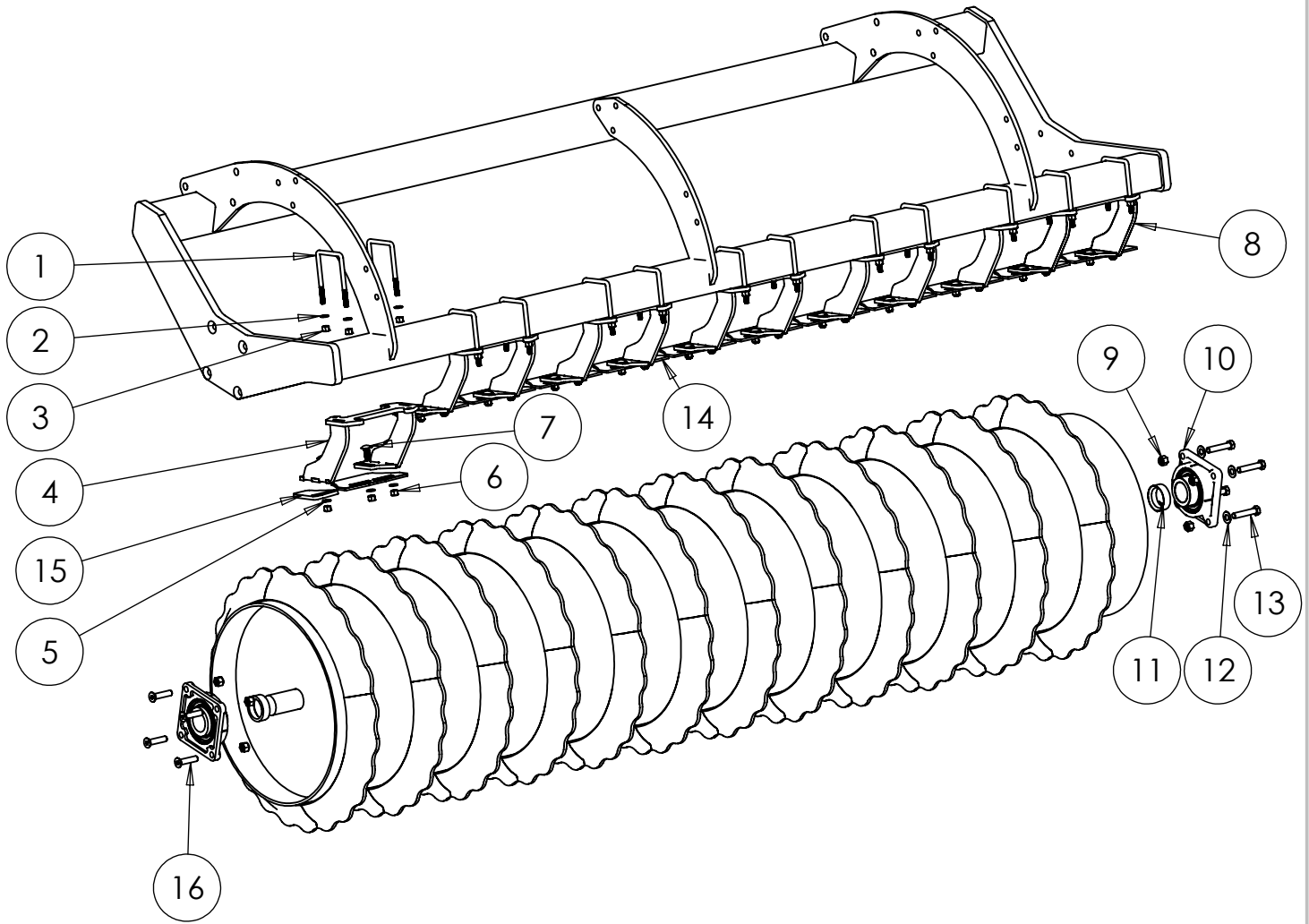

ITEM:	PART NO:	DESCRIPTION:
1	SWM12100UB	M12 X 100 U-Bolt
2	SWM12001	M12 Flat washer
3	SWM12003	M12 Plain nut
4	SW962	Scraper mount
5	SWM12001	M12 Flat washer
6	SWM12003	M12 Plain nut
7	SWM1235CHSQ	M12 X 35 Cup head square bolt
8	SW1003	Triple scraper hanger
9	SWM16004	M16 Nylock nut
10	SWB104	TMSF 60 Bearing
11	SWS3272	Packer axle collar
12	SWM16001	M16 Flat washer
13	SWM1670	M16 X 70 Bolt
14	SW651	Scraper
15	SW667	Half scraper
16	SWM1660cs	M16 socket countersunk bolt

DO NOT SCALE DRAWING

MACHINE/COMPONENT:

Sumo Quatro

TITLE:

Packer, Scraper and Bearing Assembly



Drawings and design information found herein remain the sole property of Sumo UK Ltd. Reproductions may only be made with the permission of the owner.

REVISION:

DATE: 09/04/14

INITIAL: TW

# 6.7 Drawbar Assembly 6m

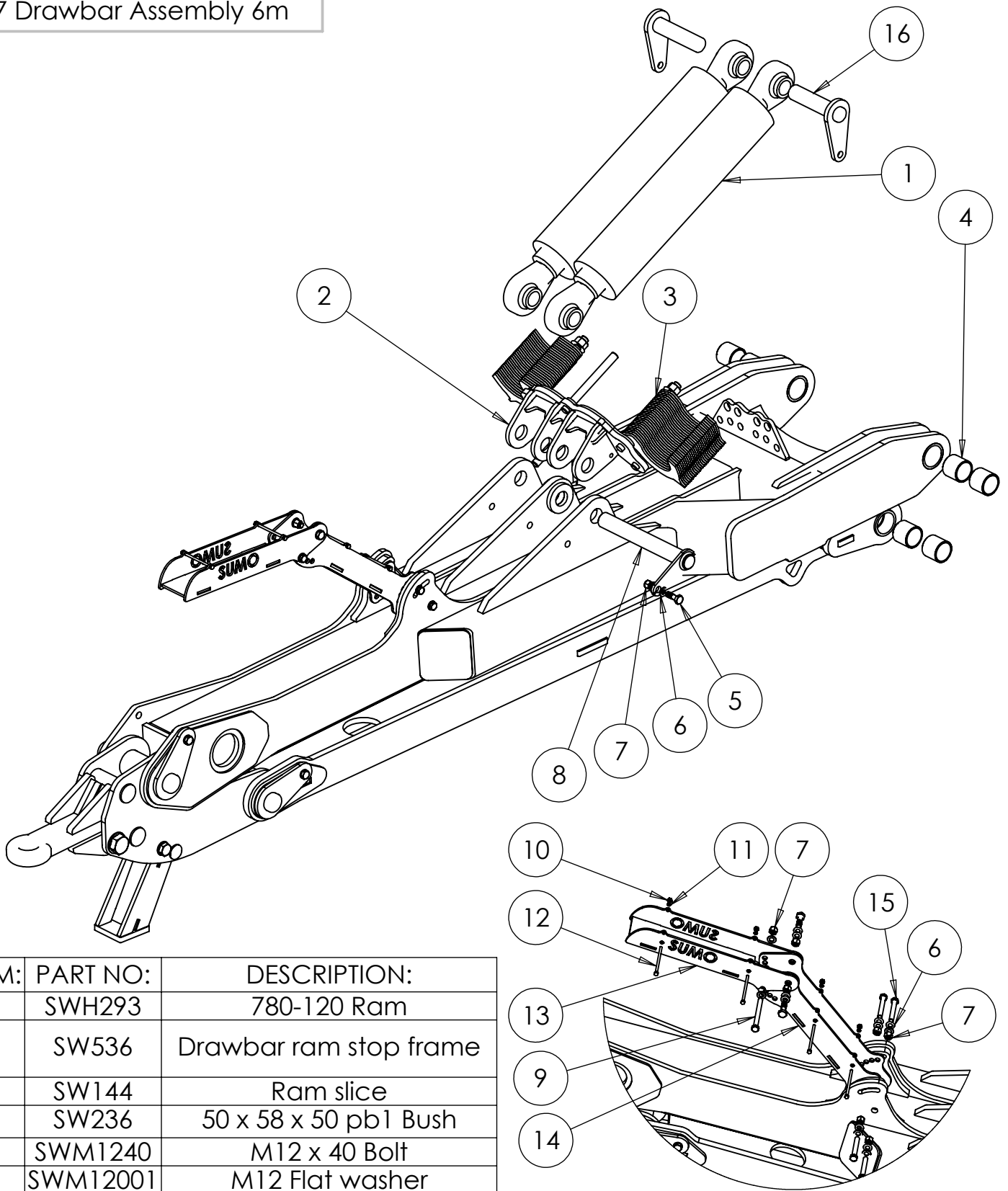

ITEM:	PART NO:	DESCRIPTION:
1	SWH293	780-120 Ram
2	SW536	Drawbar ram stop frame
3	SW144	Ram slice
4	SW236	50 x 58 x 50 pb1 Bush
5	SWM1240	M12 x 40 Bolt
6	SWM12001	M12 Flat washer
7	SWM12004	M12 Nylock nut
8	SW143	40 x 160 tabbed pin
9	SWM12130	M12 x130 Bolt
10	SWM6004	M6 Nylock nut
11	SW6001	M6 Flat washer
12	SWM12130	M12 X 130 Bolt
13	SW379	Pipe holder top section
14	SW380	Pipe holder lower section
15	SWM1250	M12 x 50 Bolt
16	SW420	40 X 200 Tabbed pin

DO NOT SCALE DRAWING

MACHINE/COMPONENT: Sumo Quatro

TITLE: Drawbar



Drawings and design information found herein remain the sole property of Sumo UK Ltd. Reproductions may only be made with the permission of the owner.

REVISION:

DATE: 09/04/14

INITIAL: TW

# 6.8 Drawbar Assembly 4m

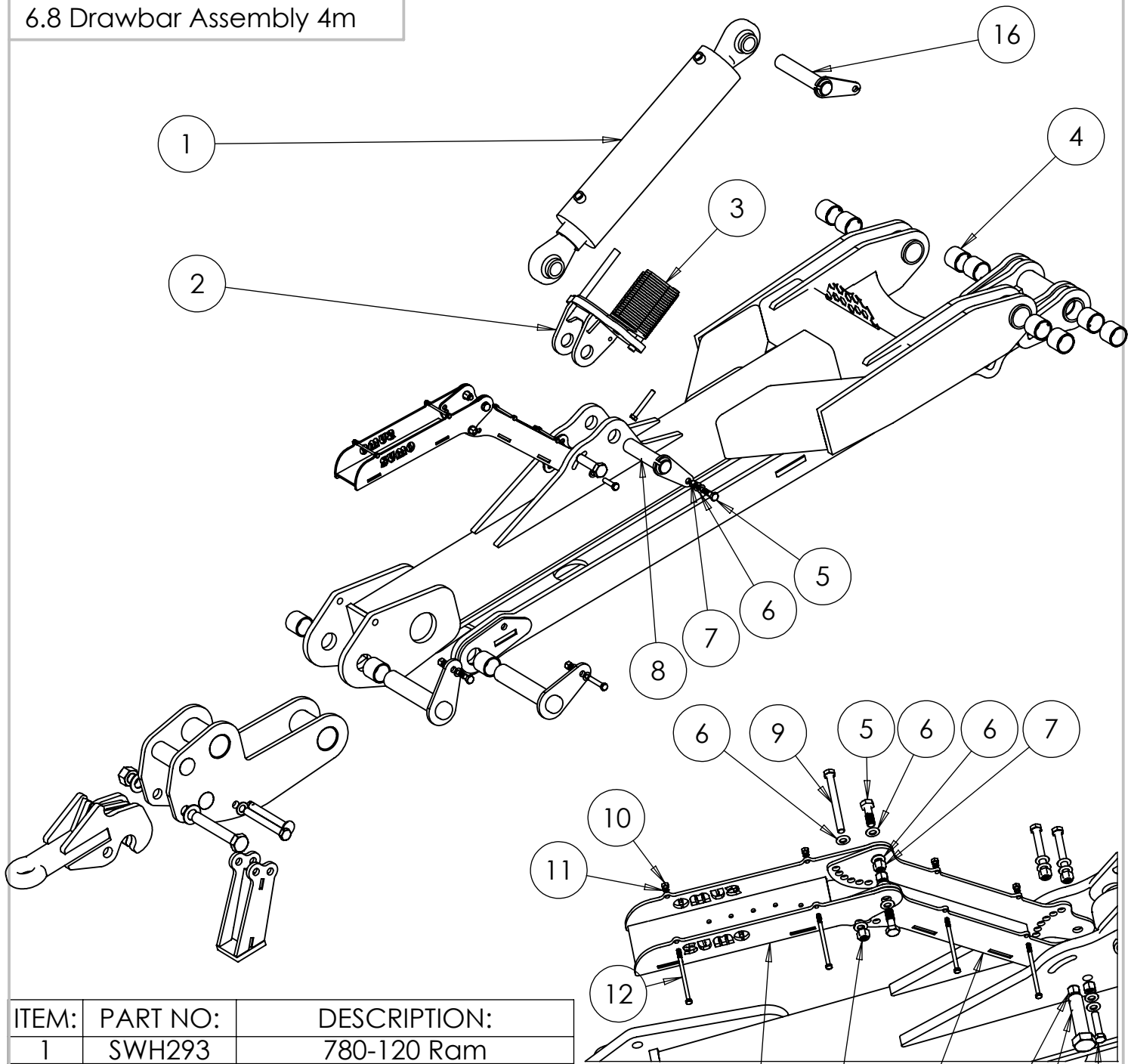

ITEM:	PART NO:	DESCRIPTION:
1	SWH293	780-120 Ram
2	SW536	Drawbar ram stop frame
3	SW144	Ram slice
4	SW236	50 X 58 X 50 pb1 Bush
5	SWM1240	M12 x 40 Bolt
6	SWM12001	M12 Flat washer
7	SWM12004	M12 Nylock nut
8	SW143	40 X 160 Tabbed pin
9	SWM12130	M12 X 130 Bolt
10	SWM6004	M6 Nylock nut
11	SW6001	M6 Flat washer
12	SWM12130	M12 X 130 Bolt
13	SW379	Pipe holder top section
14	SW380	Pipe holder lower section
15	SWM1250	M12 X 50 Bolt
16	SW420	40 X 200 Tabbed pin

DO NOT SCALE DRAWING

MACHINE/COMPONENT: **Sumo Quatro**

TITLE: **Drawbar**



Drawings and design information found herein remain the sole property of Sumo UK Ltd. Reproductions may only be made with the permission of the owner.

REVISION:	DATE: 09/04/14	INITIAL: TW
-----------	----------------	-------------

# 6.9 Drawbar Knuckle Joint

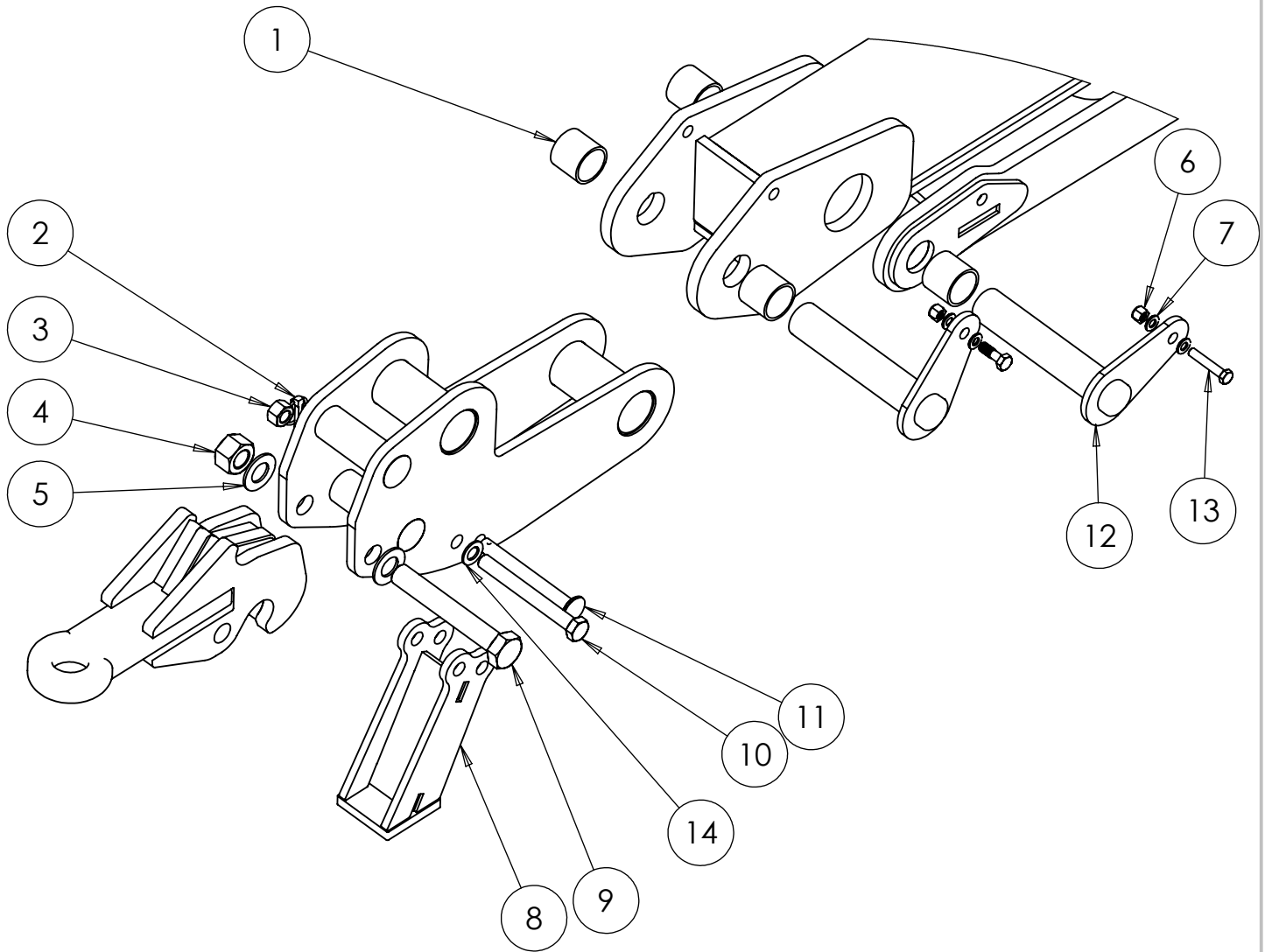

SPEC:	HOLE Ø:	PART NO:
Cat 3	51mm	SW135
Cat 4	62mm	SW632
Cat 5	75mm	SW724

ITEM:	PART NO:	DESCRIPTION:
1	SW236	50 x 58 x 50 pb1 Bush
2	SWB485	Lynch pin
3	SWM20004	M20 Nylock nut
4	SWM30004	M30 Nylock nut
5	SWM30200	M30 Flat washer
6	SWM12004	M12 Nylock nut
7	SWM12001	M12 Flat washer
8	SW136	Stand
9	SWM30190	M30 X 190
10	SWM20180	M20 X 180 Bolt
11	SW137	20MM Stright stand pin
12	SW822	50 x 200 Tabbed pin
13	SWM1260	M12 X 60 Bolt
14	SWM20001	M20 Flat washer
15	SW135	Cat 3 Towing eye

DO NOT SCALE DRAWING

MACHINE/COMPONENT:

Sumo Quatro

TITLE:

Knuckle Joint



Drawings and design information found herein remain the sole property of Sumo UK Ltd. Reproductions may only be made with the permission of the owner.

REVISION:

DATE: 29/08/2013

INITIAL: TW

# 7.0 Hydraulic Disc Ram

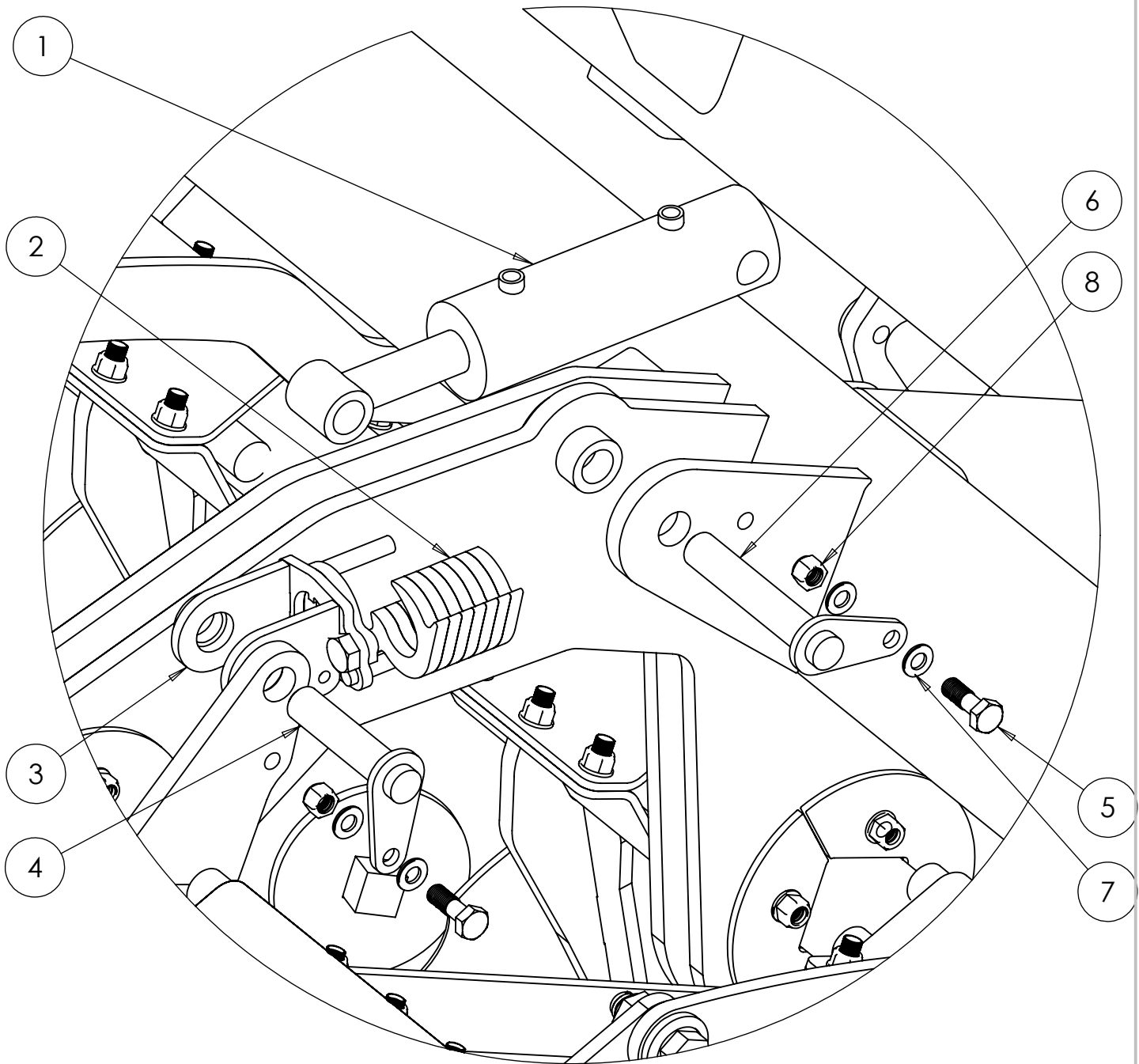

ITEM:	PART NO:	DESCRIPTION:
1	SWH113	703-1 Ram
2	SW1362	Ram slice
3	SW1334R (not shown)	Ram mount holder
	SW1334L	
4	SW1335	25 X 110 Tabbed pin
5	SWM1240	M12 X 40 Bolt
6	SW1336	25 X 140 Tabbed pin
7	SWM12001	M12 Flat washer
8	SWM12004	M12 Nylock nut

DO NOT SCALE DRAWING

MACHINE/COMPONENT:

Sumo Quatro

TITLE:

## Disc Hydrualic Ram



Drawings and design information found herein remain the sole property of Sumo UK Ltd. Reproductions may only be made with the permission of the owner.

REVISION:

DATE: 09/04/14

INITIAL: TW/MH

## 7.1 Wheels and Brakes

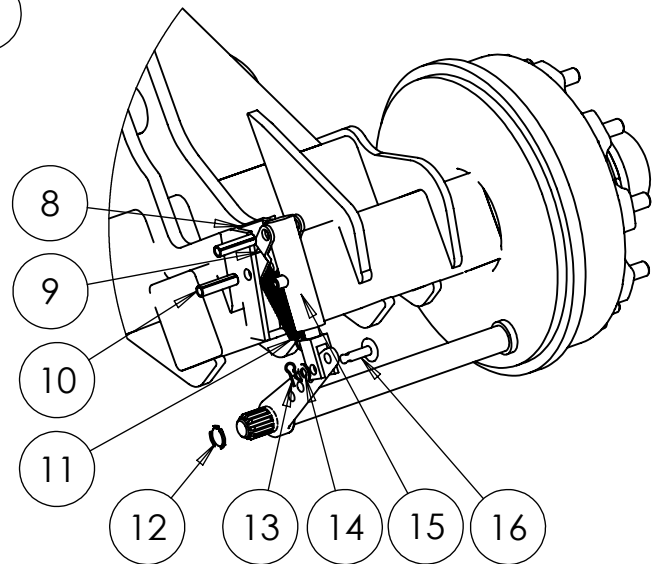
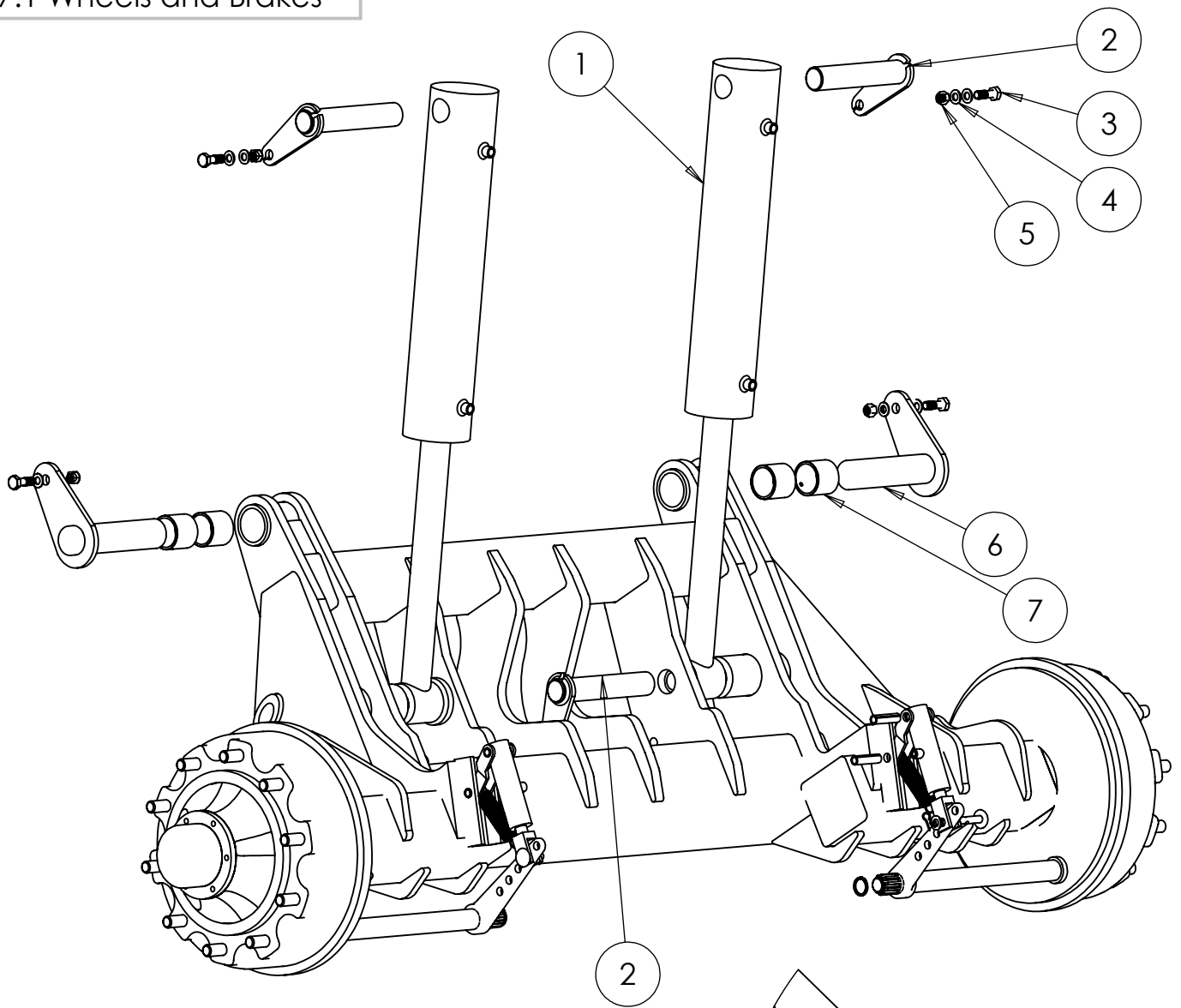

ITEM:	PART NO:	DESCRIPTION:
1	SWH430	706-4 Ram
2	SW1337	40 x 205 Tabbed pin
3	SWM1250	M12 X 50 Bolt
4	SWM12001	M12 Flat washer
5	SWM12004	M12 Nylock nut
6	SW1338	40 X 190 Tabbed pin
7	SW1339	50 X 58 X 50 Oilite bush
8	SWB194	Ram mount base
9	SWB192	Ram mount /adjuster
10	SWB191	14 X 60 Roll pin
11	SWB195	Spring and clip
12	SWB193	Circlip
13	SWB190	Small R-clip
14	SWM12001	M12 Flat washer
15	SWB134	Brake ram
16	SWB188	12mm Clevis pin
	SWB571	710 x 26.5 Rim
	SWB572	710 x 45 x 26.5 tyre
	SWB573	Rim and tyre complete unit

DO NOT SCALE DRAWING

MACHINE/COMPONENT:

Sumo Quatro

TITLE:

# 6m Wheels and Brakes



Drawings and design information found herein remain the sole property of Sumo UK Ltd. Reproductions may only be made with the permission of the owner.

REVISION:

DATE: 09/04/14

INITIAL: TW

## 7.2 Wheels and Brakes

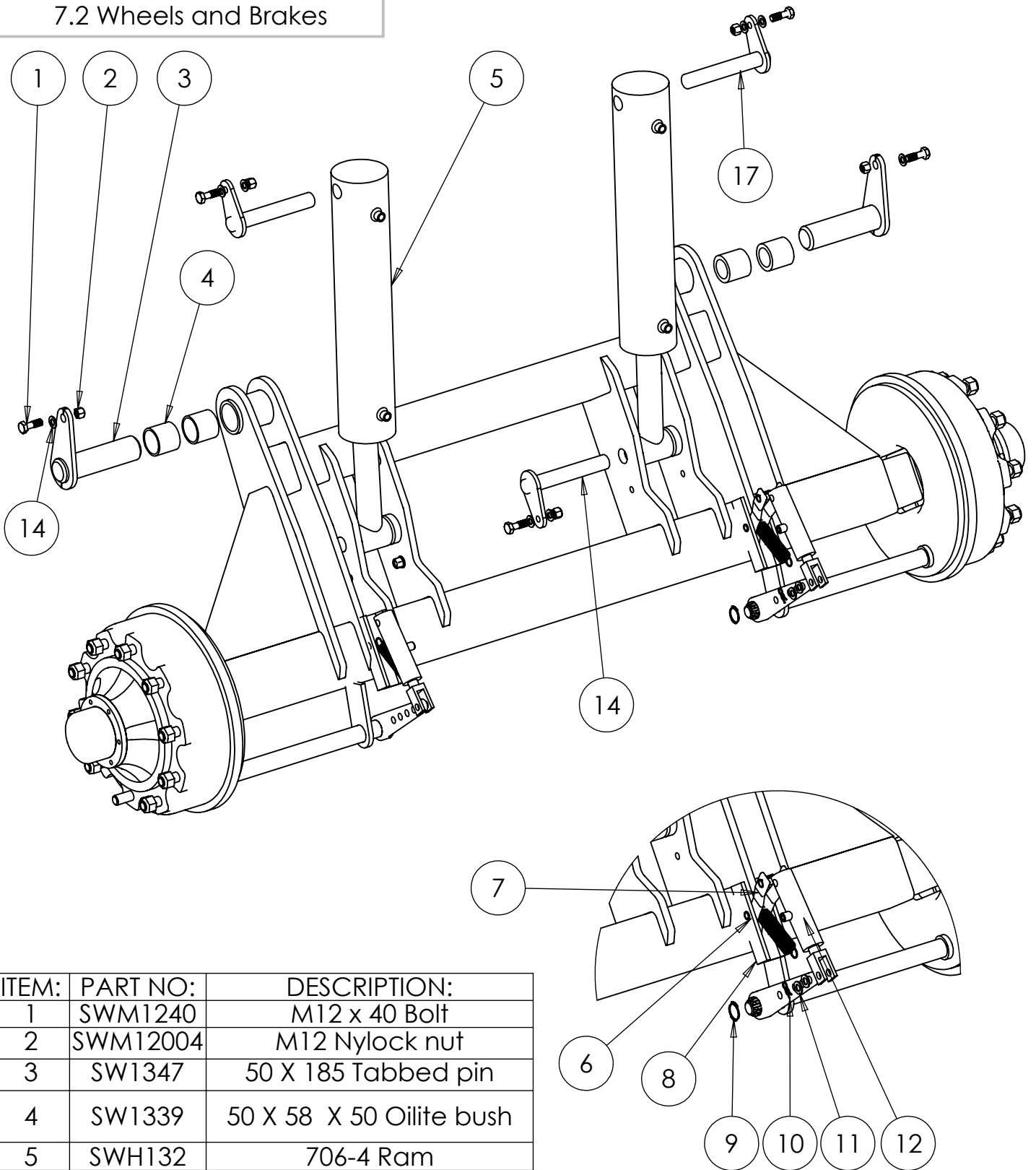

ITEM:	PART NO:	DESCRIPTION:
1	SWM1240	M12 x 40 Bolt
2	SWM12004	M12 Nylock nut
3	SW1347	50 X 185 Tabbed pin
4	SW1339	50 X 58 X 50 Oilite bush
5	SWH132	706-4 Ram
6	SWB191	14 X 60 Roll pin
7	SWB192	Ram mount / adjuster
8	SWB194	Ram mount base
9	SWB193	Circlip
10	SWB190	Small R-Clip
11	SWM12001	M12 Flat washer
12	SWB134	Brake ram
13	SWB188	12MM Clevis pin
14	SW1366	30 X 180 Tabbed pin
	SWB140	600 X 50 X 22.5 Tyre
	SWB141	22.5 X 600 Rim
	SWB414	Complete wheel unit
	SW826	30 X 185 Tabbed pin

DO NOT SCALE DRAWING

MACHINE/COMPONENT:

Sumo Quatro

TITLE:

# 4m Wheels and Brakes



Drawings and design information found herein remain the sole property of Sumo UK Ltd. Reproductions may only be made with the permission of the owner.

REVISION:

DATE: 09/04/14

INITIAL: TW

# 7.3 Leg Hydraulic Circuit

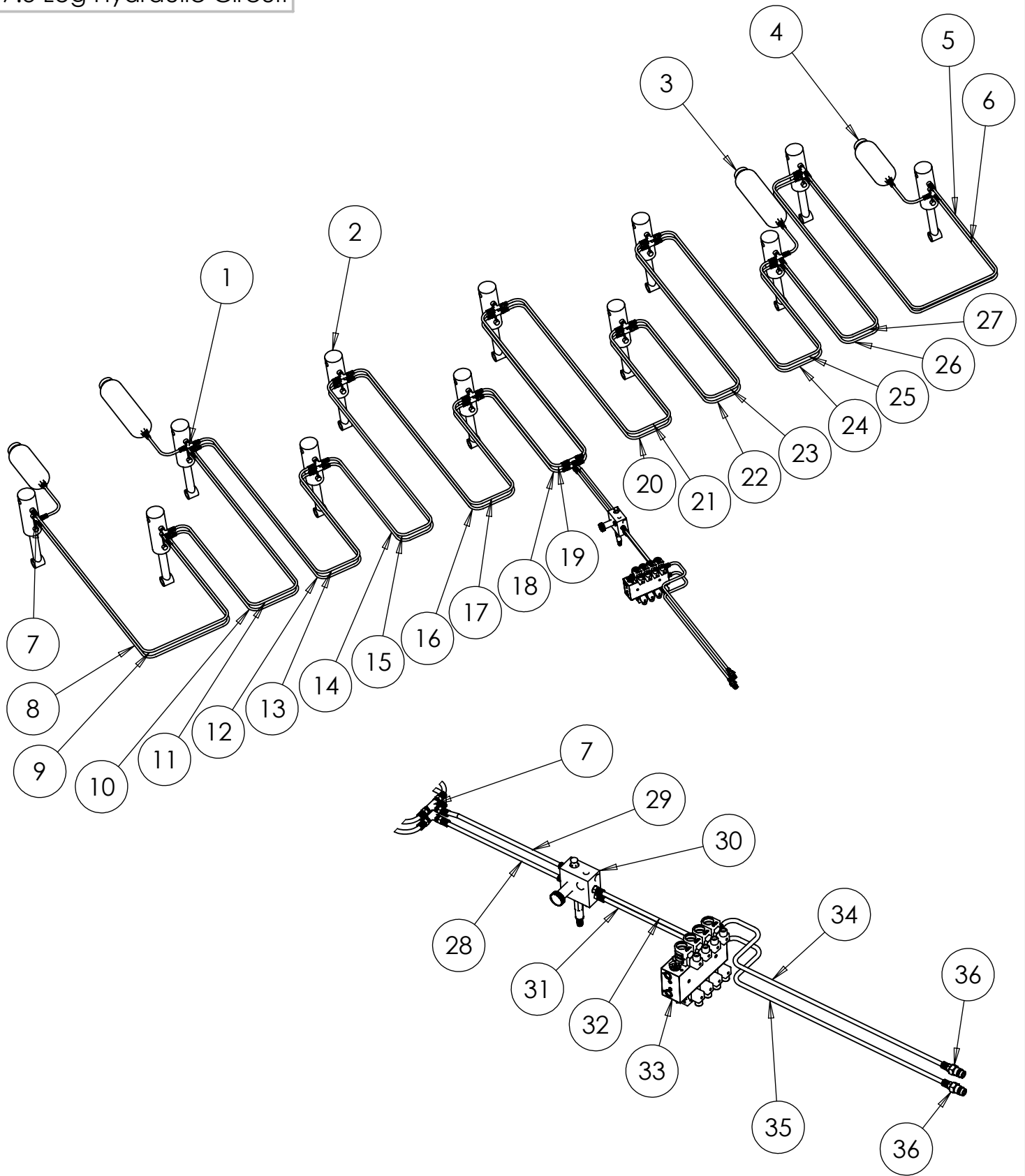

DO NOT SCALE DRAWING	
MACHINE/COMPONENT:	Sumo Quatro
TITLE:	Leg Hydraulic Circuit
	
REVISION:	DATE: 09/04/14 INITIAL: TW
<small>Drawings and design information found herein remain the sole property of Sumo UK Ltd. Reproductions may only be made with the permission of the owner.</small>	

7.3 leg hydraulic continued

ITEM:	PART NO:	DESCRIPTION:
1	SWH155	12L Cross junction
2	SWH286	705-1 Ram
3	SWH330	3L, 80 Bar accumulator
4	SWH331	1.5L, 20 Bar accumulator
5	SWH495	Leg hydraulic pipe
6	SWH496	Leg hydraulic pipe
7	SWH156	12L Tee branch
8	SWH497	Leg Hydraulic pipe
9	SWH498	Leg hydraulic pipe
10	SWH499	Leg hydraulic pipe
11	SWH500	Leg hydraulic pipe
12	SWH501	Leg hydraulic pipe
13	SWH502	Leg hydraulic pipe
14	SWH503	Leg hydraulic pipe
15	SWH504	Leg hydraulic pipe
16	SWH505	Leg hydraulic pipe
17	SWH506	Leg hydraulic pipe
18	SWH507	Leg hydraulic pipe
19	SWH508	Leg hydraulic pipe
20	SWH509	Leg hydraulic pipe
21	SWH510	Leg hydraulic pipe
22	SWH511	Leg hydraulic pipe
23	SWH512	Leg hydraulic pipe
24	SWH513	Leg hydraulic pipe
25	SWH514	Leg hydraulic pipe
26	SWH515	Leg hydraulic pipe
27	SWH516	Leg hydraulic pipe
28	SWH517	Leg hydraulic pipe
29	SWH518	Leg hydraulic pipe
30	SWH298	Auto re-set valve
31	SWH520	Leg hydraulic pipe
32	SWH521	Leg hydraulic pipe
33	SWH415	4 Channel hydraulic block
34	SWH522	Leg hydraulic pipe
35	SWH523	Leg hydraulic pipe
36	SWH147	Male quick couple

DO NOT SCALE DRAWING

MACHINE/COMPONENT:

Sumo Quatro

TITLE:

Leg Hydraulics Continued



Drawings and design information found herein remain the sole property of Sumo UK Ltd. Reproductions may only be made with the permission of the owner.

REVISION:

DATE: 09/04/14

INITIAL: TW

# 7.4 Hydraulic Wing Circuit

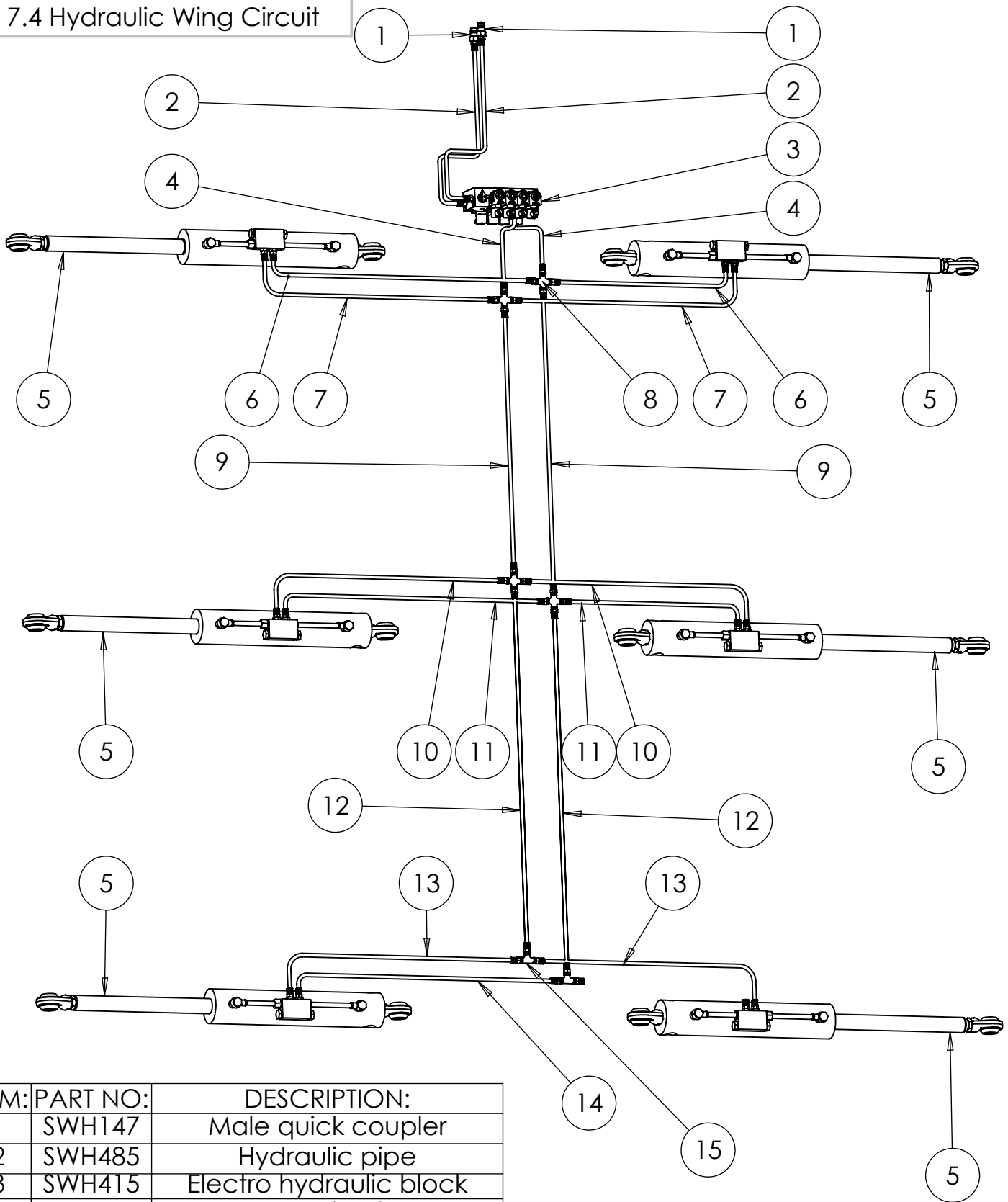

ITEM:	PART NO:	DESCRIPTION:
1	SWH147	Male quick coupler
2	SWH485	Hydraulic pipe
3	SWH415	Electro hydraulic block
4	SWH486	Hydraulic pipe
5	SWH361	706-4 Ball end ram
6	SWH487	Hydraulic pipe
7	SWH488	Hydraulic pipe
8	SWH155	12L Cross junction
9	SWH489	Hydraulic pipe
10	SWH490	Hydraulic pipe
11	SWH491	Hydraulic pipe
12	SWH492	Hydraulic pipe
13	SWH493	Hydraulic pipe
14	SWH494	Hydraulic pipe
15	SWH156	Hydraulic pipe

DO NOT SCALE DRAWING

MACHINE/COMPONENT:

Sumo Quatro

TITLE:

4m & 6m Wing Hydraulic Circuit



Drawings and design information found herein remain the sole property of Sumo UK Ltd. Reproductions may only be made with the permission of the owner.

REVISION:

DATE: 09/04/14

INITIAL: TW

# 7.5 Light Bracket

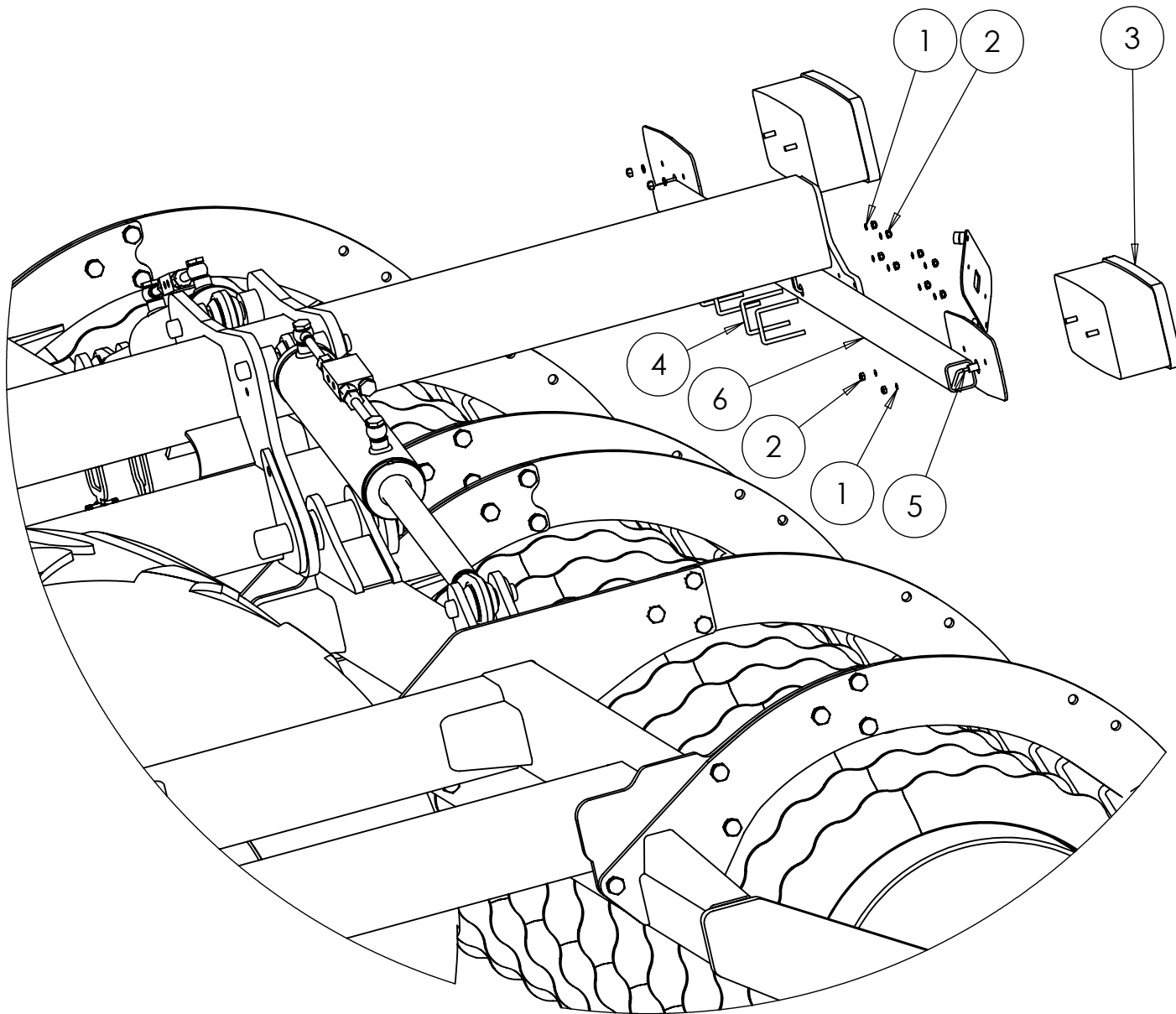

ITEM:	PART NO:	DESCRIPTION:
1	SWM8001	M8 Flat washer
2	SWM8004	M8 Nylock nut
3	SWB165	Rubberlite rear light
4	SWB556	M8 U-Bolt
5	SWB562	Wiring loom
6	SW1364	Light arm

DO NOT SCALE DRAWING	
MACHINE/COMPONENT:	Sumo Quatro
TITLE:	<b>Light Bracket</b>
	
<small>Drawings and design information found herein remain the sole property of Sumo UK Ltd. Reproductions may only be made with the permission of the owner.</small>	
REVISION:	DATE: 09/04/14 INITIAL: TW