



2015 FRONT HOPPER Operator Manual And Parts List



www.sumo1.com

Redgates
Melbourne
York
YO42 4RG
Tel. 01759 319900
Fax. 01759 319901



To activate your SUMO Warranty, you must complete this page and send it back to us at:

Sumo UK Ltd
Redgates
Melbourne
York
YO42 4RG
Tel. 01759 319900
Fax. 01759 319901

(NO REGISTRATION = NO WARRANTY)

SUMO SERIAL No:
For your own records.



Sumo customer Registration Document

NAME:

ADDRESS:

Postcode:

Telephone Number:

DATE:

SUMO SERIAL No.

DEALERSHIP
NAME AND
BRANCH:

COMMENTS:



Warranty

In this section Sumo UK Ltd. is referred to as the Company.

1. Subject to the provisions of this warranty the Company warrants each new machine sold by it to be sold free from any defect in material or workmanship.
2. If the machine or part thereof supplied by the Company is not in accordance with the warranty given in clause 1 the Company will at its option;-
 - (a) Make good the machine at the Company's expense, or
 - (b) Make an allowance to the purchaser against the purchase price, or replace the machine as soon as is reasonably practical.
3. This warranty shall not oblige the Company to make any repayment in respect of loss of profit or other consequential loss or contingent liability of the purchaser alleged to arise from any defect in the machine or impose any liability on the company other than that contained in clause 2.
4. Any claim under this warranty must be notified to the company in writing specifying the matters complained of within 12 months from the date of receipt by the purchaser or his/her nominee of the machine.
5. Any claim under this warranty must be made by the original purchaser of the machine and is not assignable to any third party.
6. If the purchaser hires out the machine to any third party the warranty shall apply only to matters notified to the Company within 90 days of the date of delivery and clause 4 shall be read as if the period of 90 days were substituted for the period of 12 months.
7. The warranty will cease to apply if:-
 - I. Any parts not made, supplied or approved in writing by the Company are fitted to the machine.
 - II. Any repair is carried out to the machine other than by or with the written approval of the Company.
 - III. Any alterations not expressly authorised by the Company in writing are made to the machine.
 - IV. The machine is damaged by accident.
 - V. The machine is abused or overloaded or used for a purpose or load beyond its design capabilities.
8. Any dispute as to whether the goods are sold free from any defect in workmanship or materials shall be referred to a single arbitrator to be agreed between the company and the buyer.

RDS Control system overview

The Artemis system (single motor kit)

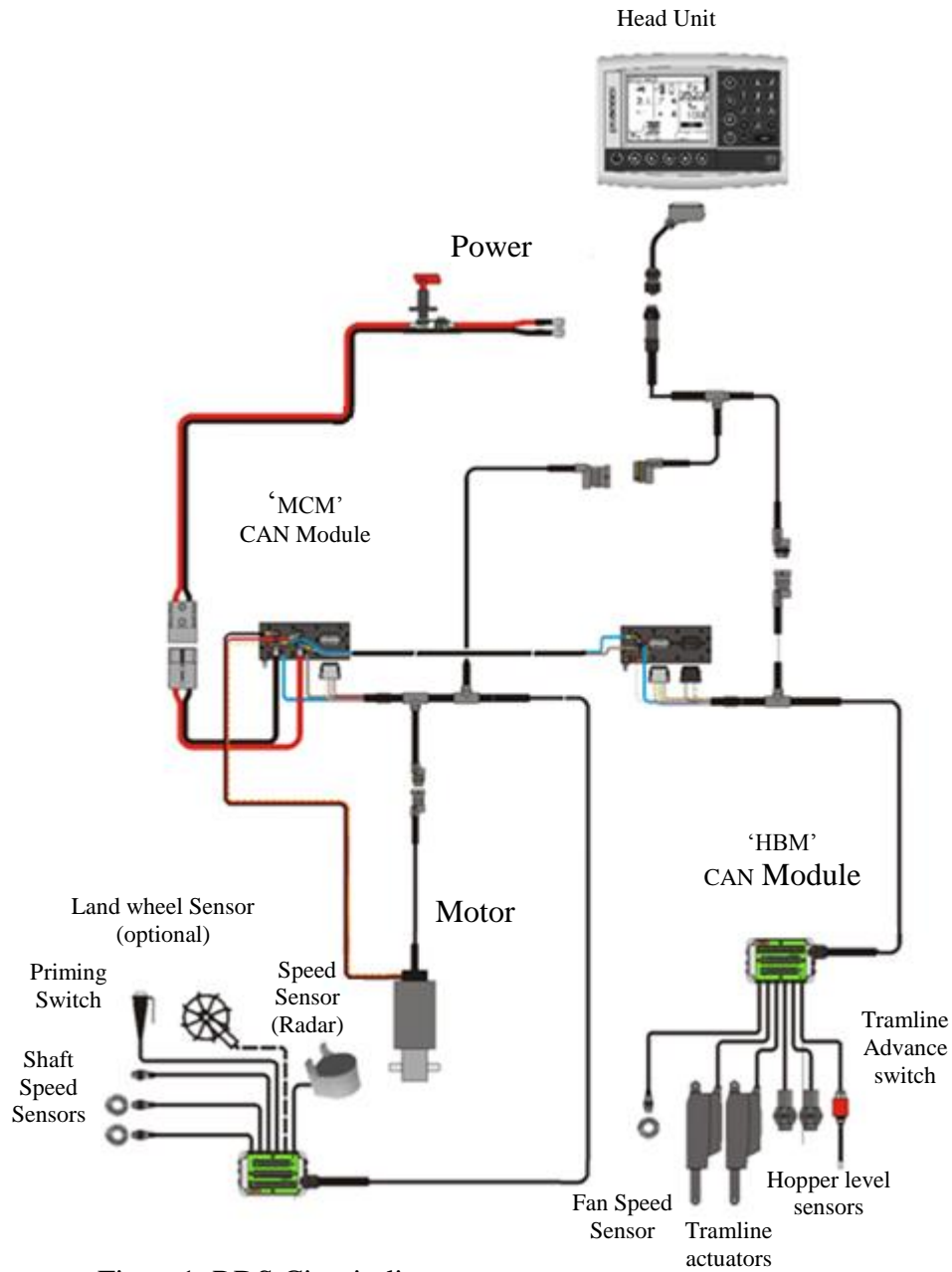

Figure1. RDS Circuit diagram

Main functions

The Artemis is designed to allow automatic, variable rate control of any drill. You can at any time, also manually override the predetermined rate as field conditions require.

The basic functions are:

- Variable Rate Control
- Tramline Control
- Forward Speed Alarms
- Hopper Level alarm
- Fan Speed & alarm
- Information totals

The instrument has a special software routine that makes calibration of the metering unit(s) very easy. In the calibration mode each metering unit is controlled via a 'priming switch' to dispense the product.

During normal operation the control system is started and stopped automatically via a magnetic sensor as the drill is put into and taken out of work. Depending on the particular installation, this sensor is triggered either by the operation of the lift/lower action or by the markers.

Control Modes and Data Logging

Automatic Control Mode

The application rate is automatically regulated as forward speed varies, to ensure that the actual application rate constantly matches a preset target rate. The application rate can be manually nudged up and down from the target rate as required.

Field data ("job summaries") can be logged and are stored in the instrument memory. Up to 75 summaries can be stored. With a GPS receiver and SD data card, as well as creating a job summary, you can also log the vehicle route and application data to a "dynamic log" file on the SD card. The job summary data is also appended to this file.

VRT (Variable-rate treatment) Control Mode

This enables the system to be controlled via treatment instructions prepared using Precision Farming software in conjunction with DGPS position data. To enable fully automatic variable-rate treatment for Precision Farming applications, the *PS 8000i* requires a suitable DGPS receiver and a formatted SD data card to implement treatment plans generated in the Precision Farming software.

A work record file is automatically created on the card to log data confirming the actual treatment. The job summary data is also appended to this file, which can be viewed in the Precision Farming software

Menu keys

All instrument functions are accessed by nine menu keys adjacent to the LCD display.

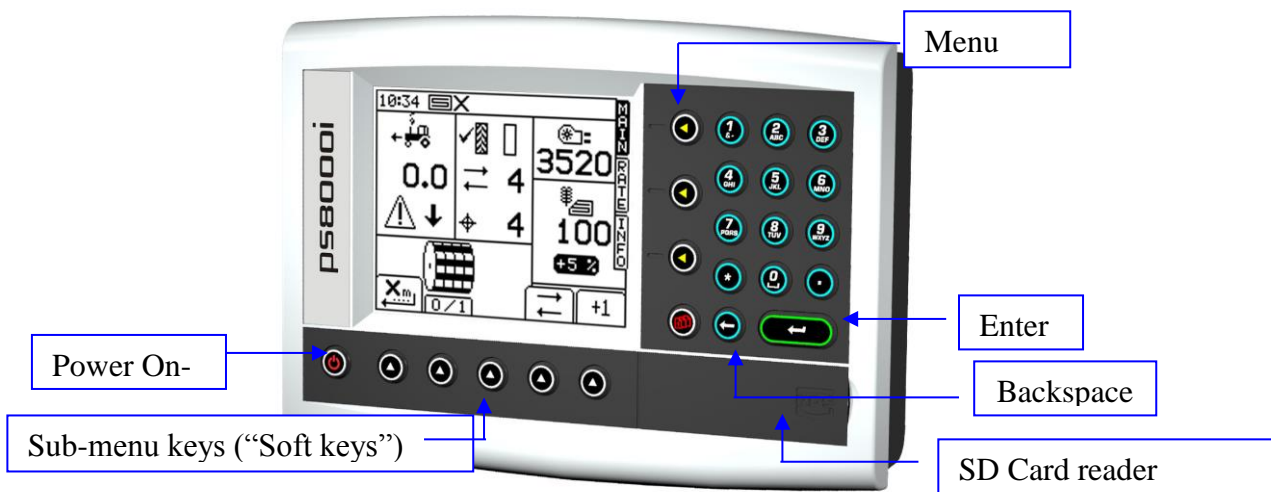

Figure 2. Artemis control box

The four menu keys to the right of the screen access the primary screen pages (those viewed during normal operation). There are three primary screens MAIN, RATE and INFO for normal operating functions, and a SETUP screen for calibration functions.

The five sub-menu keys below the screen control the various display functions and settings for each of the primary screen pages. Text or icons are displayed adjacent to the sub-menu keys to denote their function.

RDS Control Unit Operation

Status Indicators

All the operating screens have a status bar at the top of screen displaying the time as well as a number of different icons. These icons indicate the following:

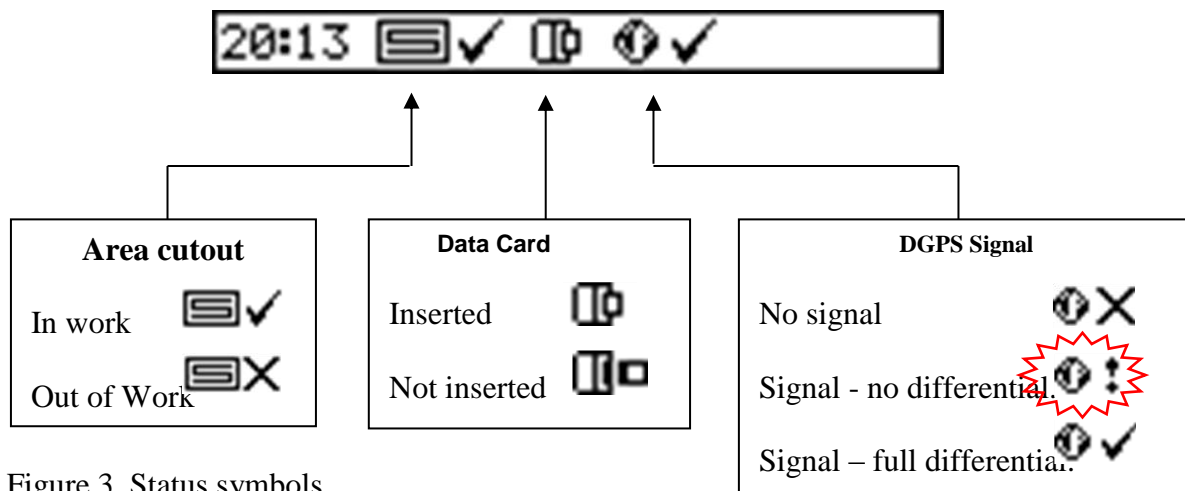

Figure 3. Status symbols

NOTE: The Data Card and GPS icons are only displayed when these functions are enabled via the SETUP menu.

'MAIN' screen

The instrument will always default to the MAIN screen on startup. The MAIN screen is divided into 5 sections displaying the following functions,

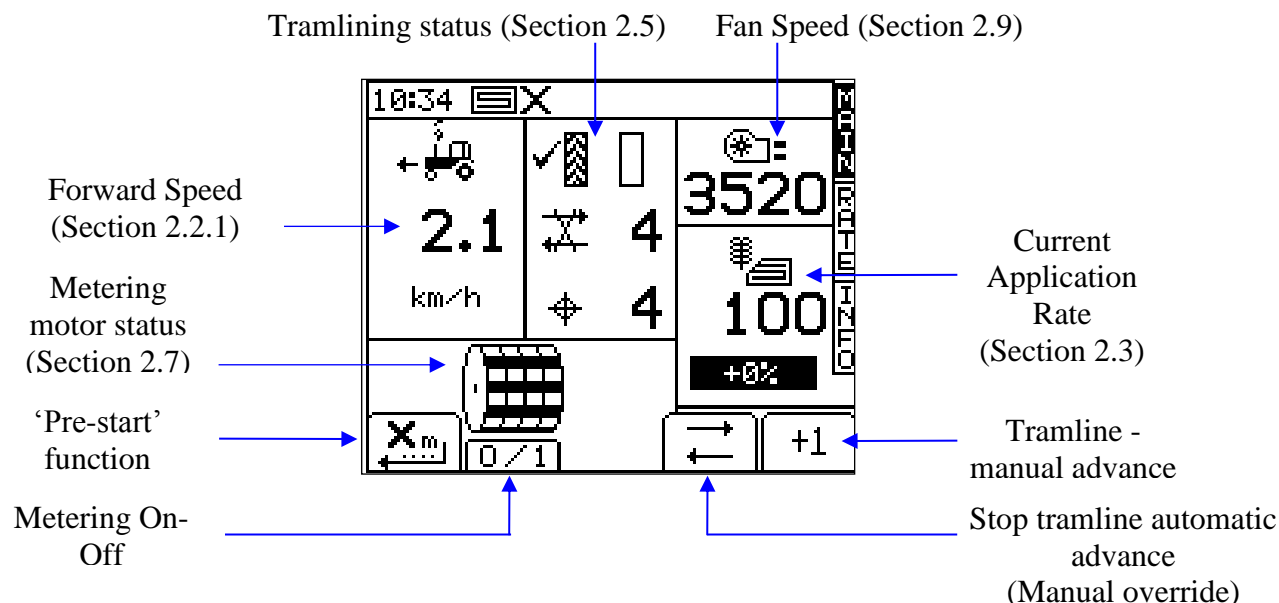
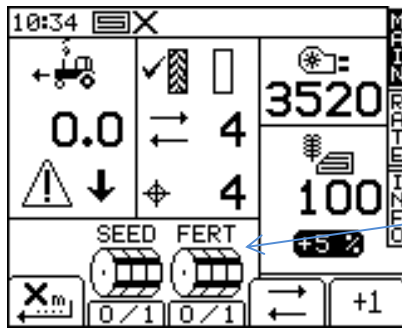

Figure 4. MAIN screen (single product / single metering)

NOTE: The Metering motor status part of the display will appear differently depending on the drill configuration



Display as Fig.4 except as shown



Figure 5. MAIN screen (dual product / single metering)

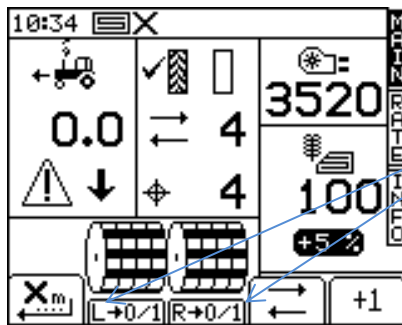

Display as Fig.4 except as shown



Figure 6. MAIN screen (single product / dual metering)

1 Forward speed display and alarm functions

Display smoothing

Except for sudden changes in speed, the forward speed displayed at any moment will be the average speed calculated over 3 seconds.

Speed alarms on MAIN screen

The instrument is programmed with low and high forward speed alarms.

If the drill is in work and the speed is less than 0.5 km/h then this section of the MAIN display will flash the following

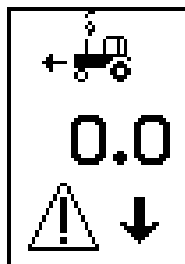

If the drill is in work and the speed is above the maximum that proportional control can achieve (indicated on the RATE screen), then this section of the MAIN

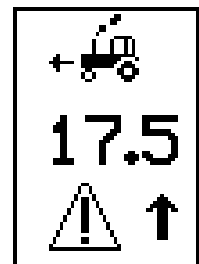

When setting a new target rate on the RATE screen, the instrument re-calculates and displays the maximum forward speed at which that rate can be maintained (Fig.7). It is calculated from the rate set, drill working width, current calibration factor, gearbox ratio and maximum motor speed.

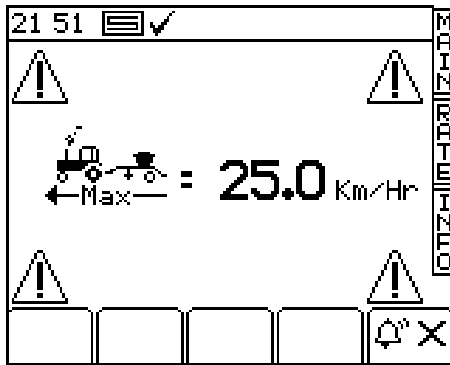



Figure 7. Maximum speed reminder

Simply press the  key to return to the RATE screen.

NOTE: If the speed is too low, the operator must open the metering unit and re-calibrate to increase the calibration factor (ref. the 'Calibration' manual).

2 Tramlining status/functions

The MAIN screen shows the current status of tramlining.

Tramline rhythm:-

Output status
( = ON)

Current bout

Target no. of
bouts

Symmetrical

Assymetrical left

Assymetrical Right

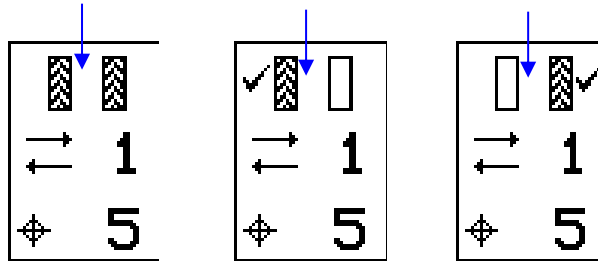



3 Advancing the bout number

On starting up the instrument the tramline sequence always starts at '1'.

If necessary, press the  key to select the correct current bout number, e.g. if entering work on a bout other than bout 1 of the tramline sequence.

4 Holding the bout number

Press the  key to hold the current bout number (e.g. to prevent the bout no. advancing if it is necessary to take the drill out of work, or depending on the drill setup - lift a marker, to negotiate a field feature).

The  icon indicates that the bout no. is held. Press the  key to resume normal bout advance.

NOTE: The tramlining sequence is set up via the SETUP page (ref. section 2.5).

'RATE' screen

This screen allows the drilling rate to be adjusted. Either kg/ha or seeds/m² units can be set via the SETUP menu.

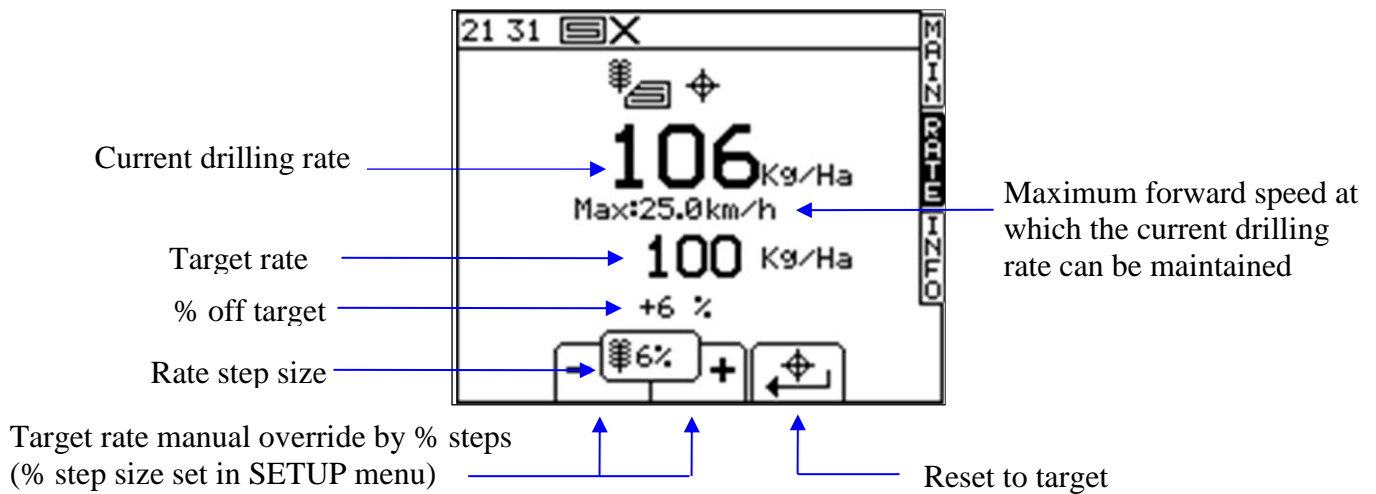

Figure 8. RATE screen - single product

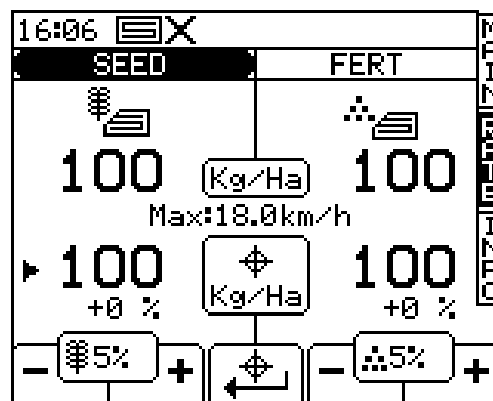

Figure 9. RATE screen - dual product

NOTE: The maximum forward speed shown is the lowest for the 2 products.

1 Setting /overriding the target rate

To set the target rate, simply enter the value and press the ENTER key to confirm.



To set the target rate or manually adjust the rate for either product, first press the ENTER key to select SEED or FERT.

The application rate on the MAIN screen is the same as that shown on the RATE screen above. If however on the rate screen, the current rate is manually adjusted above or below the target rate, then this number will flash (on for 1 second, off for 0.5 second).

When operating from a treatment plan, then this number should only flash if the instructed rate has been changed using the '+' or '-' percentage buttons on the rate screen.

To override the target rate, use the keys. The % step is configured from the SETUP menu.



To return to the target rate, press the key.

Both products are reset to their respective target rates

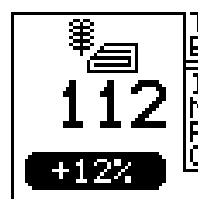

'INFO' screen

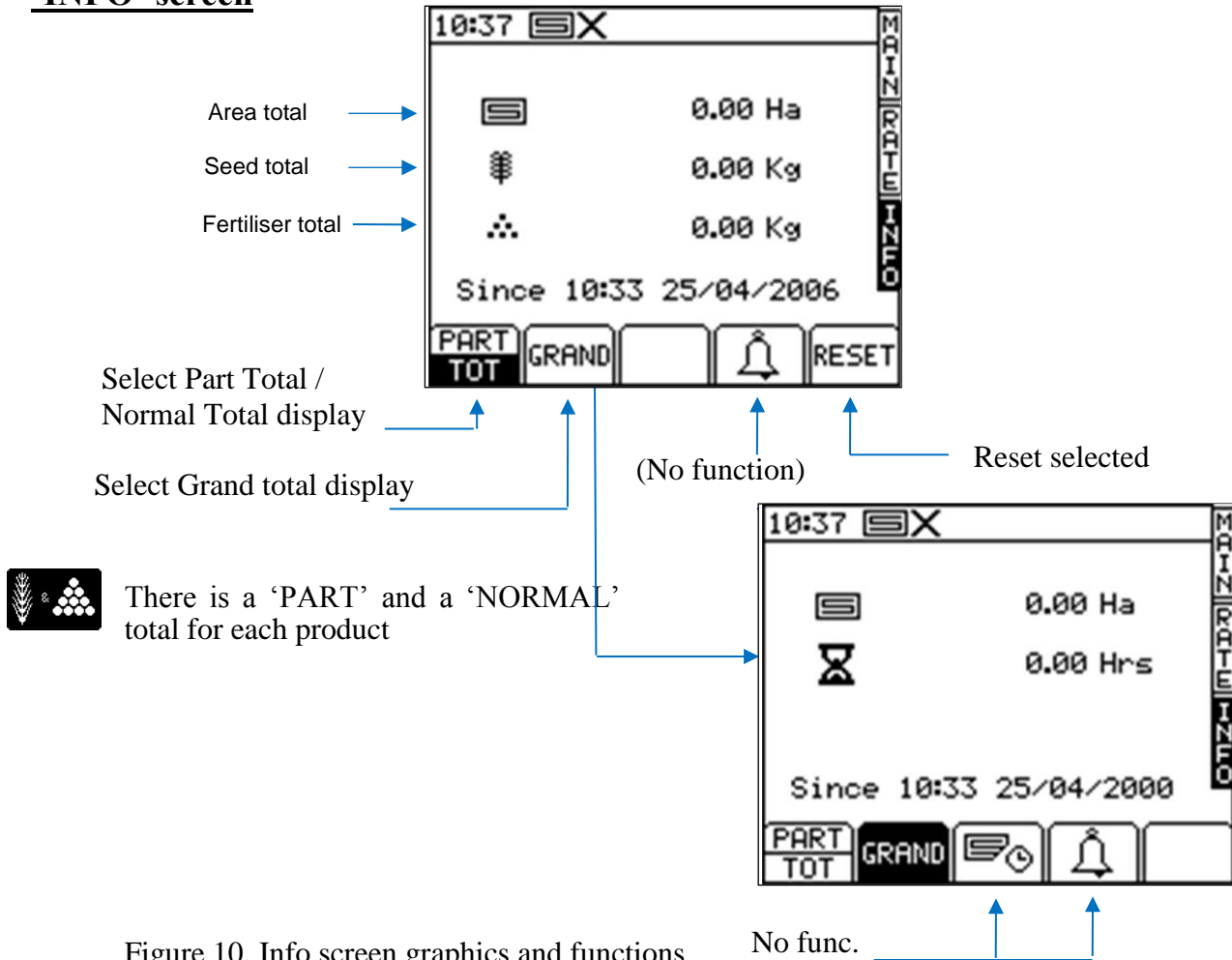

Figure 10. Info screen graphics and functions

Tramlining

To set the desired tramline rhythm, select the SETUP screen and press the key.

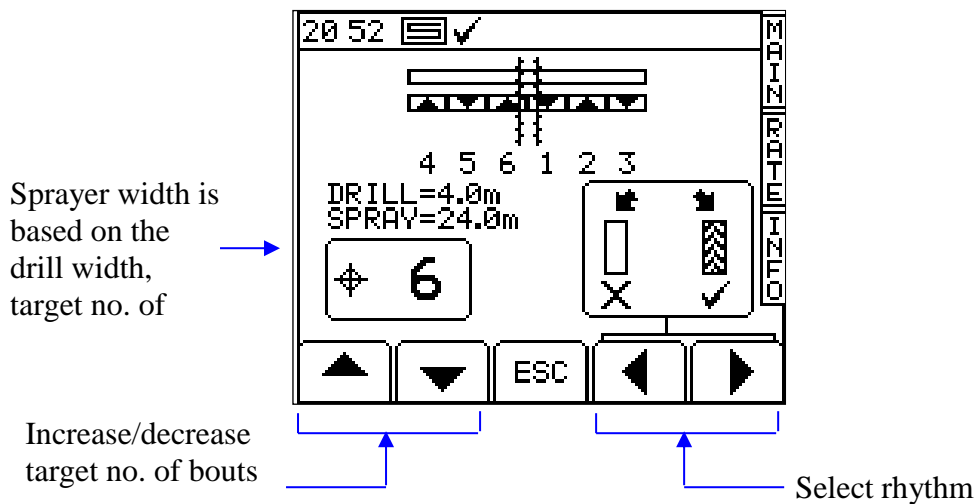
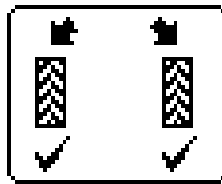
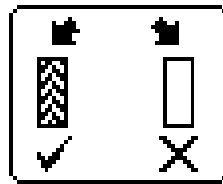

Figure 11. Tramline set up screen

The target no. of bouts can be selected up to 10, with, symmetrical, asymmetrical left or asymmetrical right rhythm selectable.



Symmetrical



Asymmetrical left

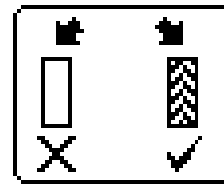

Asymmetrical right

The instrument displays the drill/sprayer width combination for the selected target no. of bouts.

Beyond 10 bouts, a number of special asymmetric rhythms can be selected to suit the following drill/sprayer width combinations.

- '8-pass' 4m drill/10.7m sprayer, 4.5m drill/12m sprayer
- '10-pass' 4m drill/10m sprayer, 6m drill/15m sprayer
- '10-pass' 4m drill/13.3m sprayer, 6m drill/20m sprayer
- '14-pass' 3m drill/14 sprayer, 4m drill/18.7m sprayer
- '16-pass' 4m drill/21.3m sprayer, 4.5m drill/24m sprayer
- '18-pass' 4m drill/18m sprayer
- '22-pass' 4m drill/29.3m sprayer

The tramline sequences ('L' – Left, 'R' – Right) are as follows:

Bout	8-pass	10-pass	10-pass	14-pass	16-pass	18-pass	22-pass
1							
2	R	R	L				
3				L	R	L	
4	L	L					L
5	L		R				
6			R				
7	R	L		R		R	
8				R	L		
9		R	L		L		
10							
11							R
12				L		R	R
13							
14					R		
15							
16						L	
17							
18							
19							L
20							
21							
22							

Metering motor – manual override/Half-Width Shut off (HWSO) drilling

As fitted to 6m and above drills. When wanting to only drill with one half of the machine, it is achievable by switching either the right or the left hand side motor. Seed is then delivered to just one of the distribution heads and subsequently just one half of the machine.

Simply press the desired key(s) to switch off either the left half or the right half of the machine.

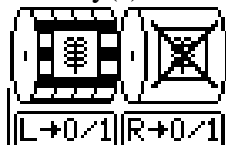

The metering motor(s) can be stopped using this system manually as desired, if for example:

- An area of field needs further cultivation before seeding.
- In the case of a front-mounted hopper, the metering motor is switched off just before the end of the bout to clear the seed through (the opposite of the 'pre-start function').
- You want to drill at half-width in order to correctly align tramlines

When half width is enabled the main screen displays as follows:

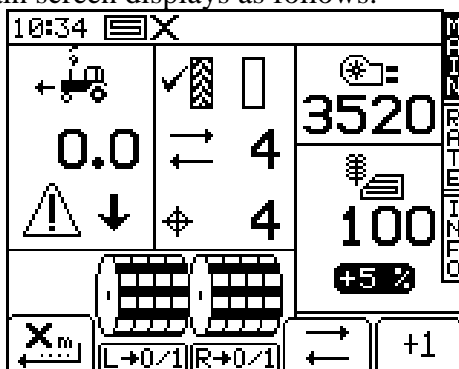

Figure 12. Usual operating screen for single product, dual metering.

With one half shut down (the right in this case) the screen displays as follows:

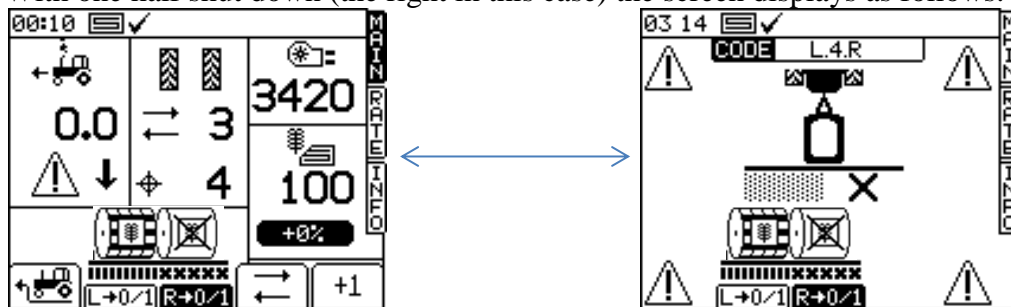

Figure 13. HWSO operating screen (RHS shut) and the reminder screen

If left or right is switched off and a product calibration is initiated the following screen is shown:



Figure 14. Select full width warning.

The appropriate side can then be turned back on again. This screen will remain shown until the appropriate motor is switched back on at which point product calibration can then be commenced normally. If the alarm cancel button is pressed the P*Si* simply goes back to the previously shown screen.

Product calibration

1 Initial product calibration

Set up the drill in the usual way for a bucket test.

1. From the SETUP screen, press the  key.



2a. If the instrument is configured for dual products, first select the product you want to calibrate (Fig.15).

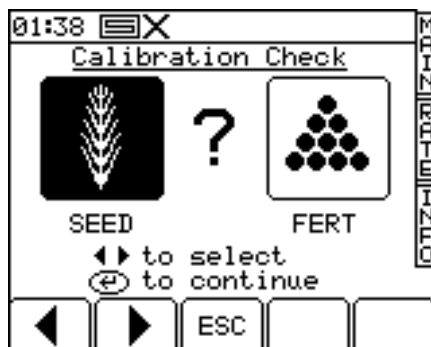

Figure 15. Dual product/Single metering



2b. Or if configured for dual metering, select the metering unit to be calibrated (Fig. 16).



Figure 16. Single Product/Dual metering

3. Otherwise, select the desired units then enter the weight required to be metered out (Fig.17) and press ENTER. The metering unit will then operate at the programmed calibration speed to dispense the correct amount of product, then stops. The instrument then displays a weight figure based on the existing programmed product calibration factor.

NOTE: If a priming switch is employed for calibration the calibration routine will commence from Fig. 15.

4. Weigh the contents of the container, and then enter the *ACTUAL* weight dispensed (Fig.19) and press ENTER to confirm.

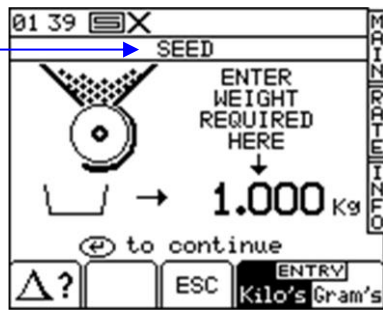

Figure 17. Pre-calibration screen

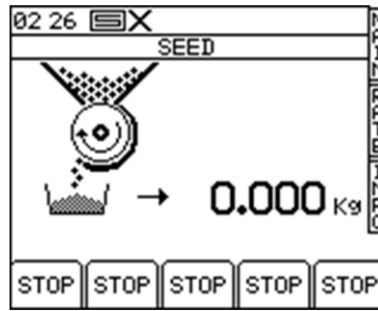

Figure 18. During calibration screen

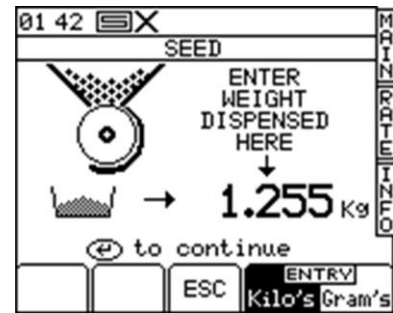

Figure 19. Calibration correction screen

NOTE: The heading will be either SEED / FERT / LEFT / RIGHT according to steps 2a , 2b.

5. Press ENTER again for the instrument to re-calculate and display the new calibration factor in kg/rev, the error %, and the maximum forward speed that is permissible based on the application rate set for the product (Fig.20).



Figure 20. Calibration confirmation screen

6. Press ENTER again to confirm and store the new calibration factor, or press ESC to return to the SETUP menu screen.



It is recommended to reset the PART TOTAL to zero before commencing drilling. This will enable you after drilling an area, to quantify any error in the calibration factor by logging the theoretical amount of product used against a known amount used (a whole bag for example).

You can then adjust the calibration factor precisely, if necessary (section 2.7.2).

2 'CALIBRATION NUDGE' - Adjusting the calibration factor

The 'calibration nudge' procedure enables you to adjust the existing calibration factor without having to redo a bucket test.

1. First note down the PART TOTAL for the product displayed in the INFO screen. This is the theoretical quantity that the instrument has calculated.

From the SETUP menu, press either the  key (CAL. CHECK), or the  key (DRILL SETUP).



If the instrument is configured for dual products, first select the product you want to calibrate (Fig.15).



If configured for dual metering units, likewise, first select the left or right unit (Fig.16)

2. From either screen, press  key to select the 'Calibration Nudge' screen (Fig.21).



Figure 21. Calibration nudge screen



Figure 22. Enter amount screen

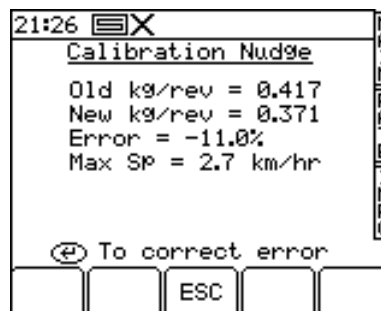



Figure 23. Nudge confirmation data

3. Enter the theoretical ('Expected') weight noted from the INFO screen at step 1 and press ENTER twice.
4. Enter the actual weight dispensed and press ENTER twice.
5. The cal factor is re-calculated and displayed along with the % error and maximum forward speed (Fig.23). Press ENTER again to store the new factor.

Set Fan Speed and Hopper Level alarm thresholds

To view the alarm thresholds (Fig. 24), from the SETUP menu, press the  key.

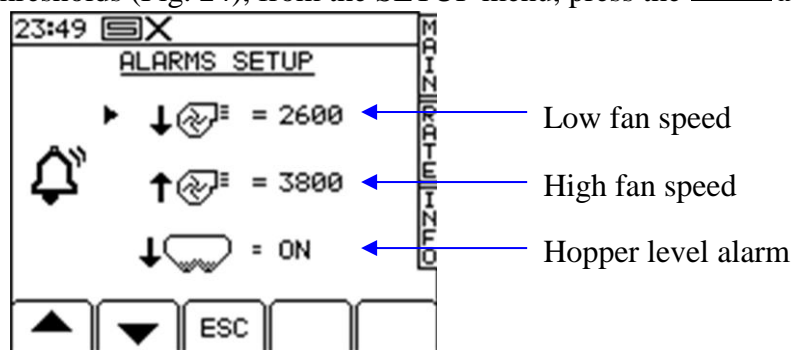



Figure 24. Alarm set up screen

To adjust the threshold, simply enter the figure and press the ENTER key.

Speed simulation

In the unlikely event that the radar speed sensor stops working, you can continue drilling by simulating a forward speed signal. Remember though that your actual forward speed should match the simulated speed as close as possible, otherwise the drilling rate will not be correct. Drive faster than the simulated speed and you will under-apply, and vice-versa.

To set the simulated forward speed, from the SETUP screen, select '1 User Setup' then '2. Speed Sensor Setup'.

Press the  key (Fig.25), then enter the desired sim.speed (Fig.26).

Press the ENTER key again to start speed simulation.



Figure 25. Speed factor screen



Figure 26. Simulated speed screen

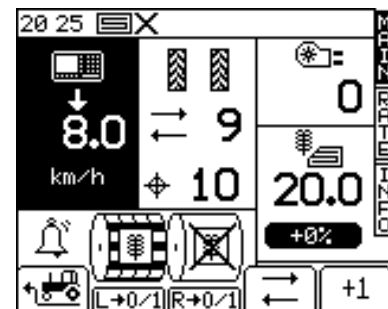

Figure 27. Calibration nudge screen

As long as speed simulation is running, the forward speed display on the MAIN screen will flash (Fig.27)

NOTE: The pre-start function works as normal with a simulated speed.

Select units / Rate step%

From the SETUP screen, select '1 User Setup' then '3. Customise'.

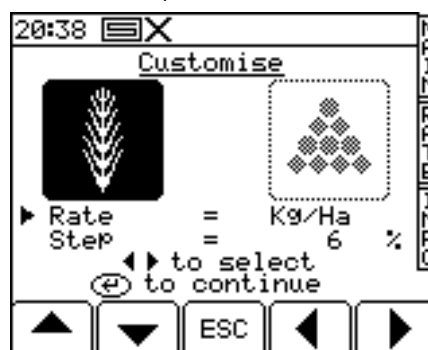

Figure 28. Rate units screen



If the instrument is configured for dual products, first select the product with the LEFT/RIGHT arrow keys (Fig.28).

Use the UP/DOWN arrow keys to select the parameter.

Use the LEFT/RIGHT arrow key to select the units (kg/ha or seeds/m²).

Use either the LEFT/RIGHT arrow keys to adjust the rate, or simply enter the desired figure using the keypad and press ENTER to confirm.

Speed Auto-cal. routine

This procedure is required to calibrate the radar for the location it is positioned in. Certain machines have differing positions and proximity to the ground. Tractor pickup hitch, drawbar fluctuations etc. can all affect the perceived forward speed signal.

1. Press the red button 

2. Press "1" user setup

3. Press "2" speed sensor factor

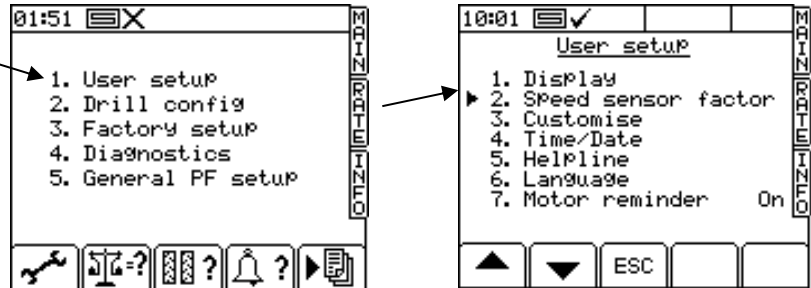

Figure 29. Main menu screens

4. Go down to option 2 and press enter.

N.B. At this point, you can manually edit option 1, the SSF as displayed.

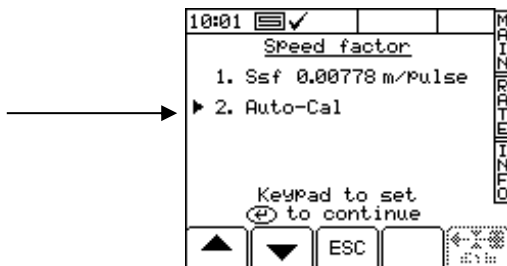

Figure 30. SSF screen

5. When you are ready, with the machine **in work, in a field**, press enter to start.



Figure 31. Auto-Cal test in progress screen

6. Drive at any speed exactly 100m and stop
7. Once stopped, press enter to complete process
8. When complete save the new factor (Don't forget that 0.0076 is the default setting).

GPS Configuration

Hardware/software set up Procedure to receive a GPS speed signal and variable seed rate signal

Outline procedure:

- 1, Port set up
- 2, Baud rate (match GPS device to the RDS box)
- 3, Select the speed sensor option.
 To use GPS, choose NMEA VTG, option 4
 To use the radar, choose option 3
- 4, Load Variable rate maps from the log page



Port cable configuration

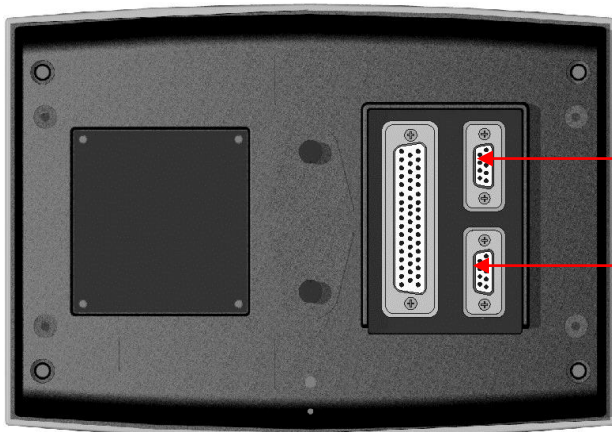

Top Port options

- **GPS** – e.g. GPS 16 or any compatible receiver

Bottom Port options

- **Receiving VRT instructions** from OEM controller
 e.g. Fieldstar Type 1
 Soyl Opti
 Agrocom ACT
 Yara-N Sensor
- **receiving VRT instructions from SD card**
 e.g. RDS PF MODULE

Figure 32. Port connections

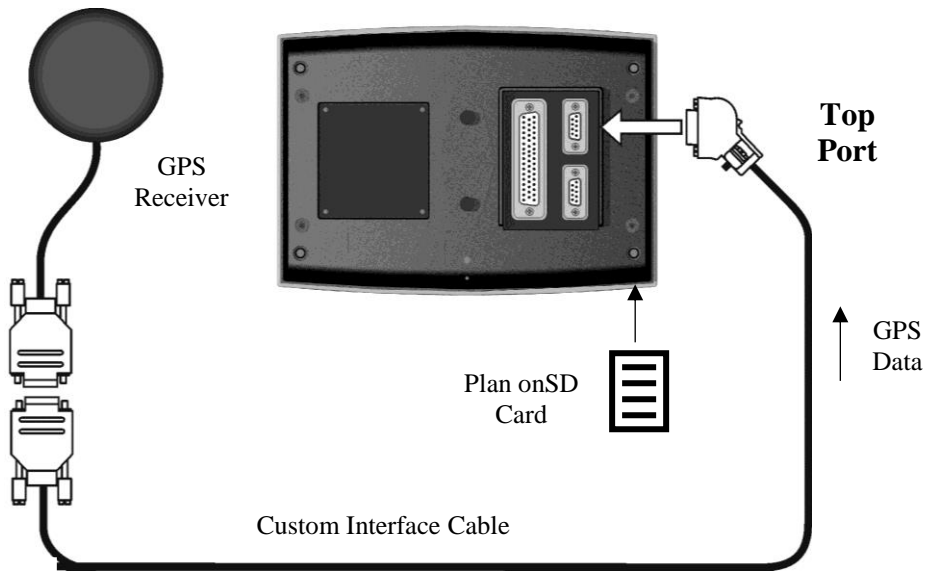

Figure 33. Typical Setup – Psi sending rate instructions via SD card

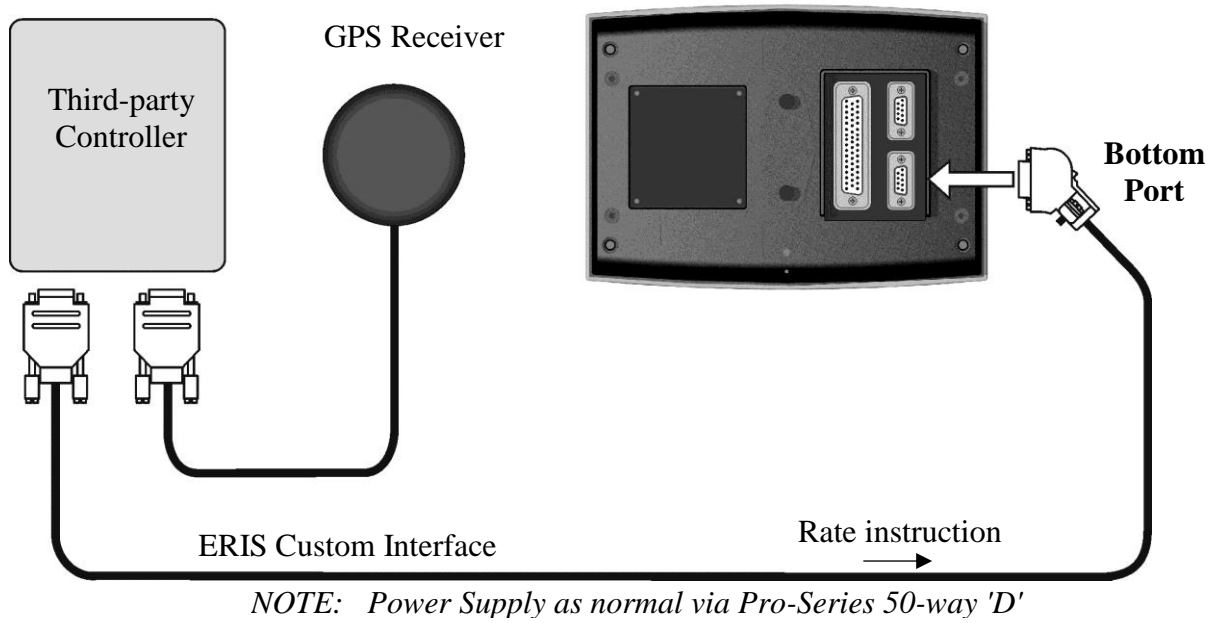

Figure 34: Typical Setup- Psi receiving rate instructions E.G Soyl Opti, John Deere Greenstar

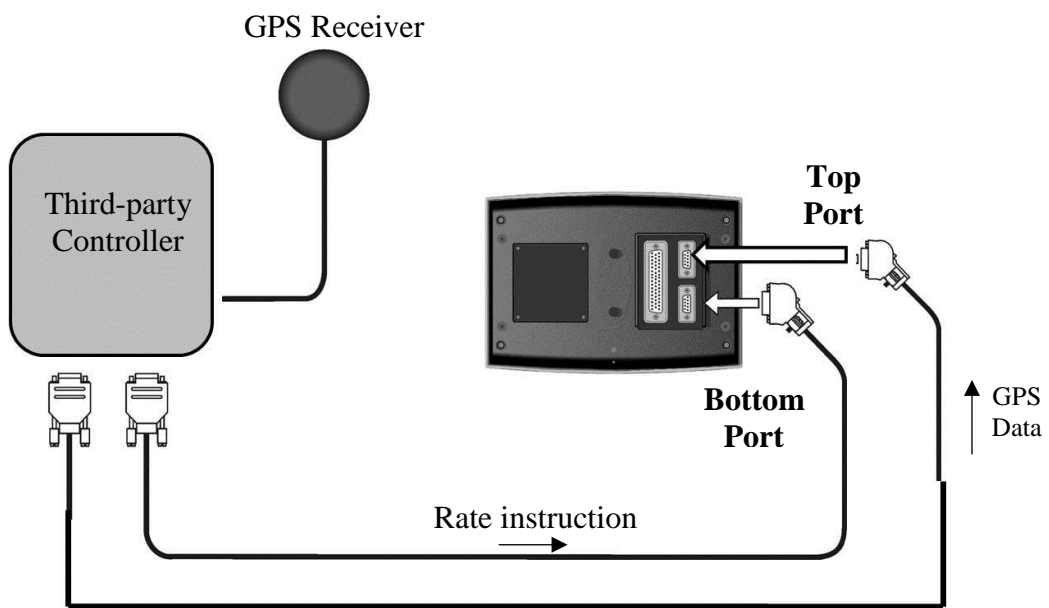



Figure 35. Typical Setup- Psi receiving rate and GPS instructions via separate cables E.G Trimble

Head Unit Configuration - Port Settings

Having connected the hardware to the appropriate port(s), you need to configure the port settings.

Press  to select SETUP then,

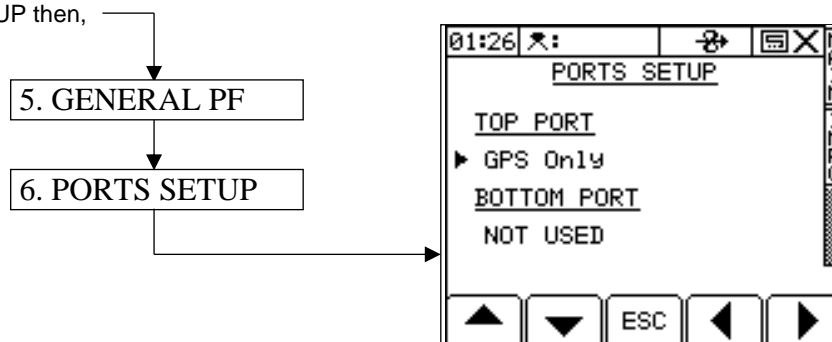

Figure 36: Configuring the ports process & screen

The 'Ports Setup' screen can also be accessed via the Technician Config menu (PIN=1234). Use the arrow keys to select the correct option and press ENTER to confirm.

Table 3: Port Options

Top Port	Function
NOT USED	Factory default setting
GPS ONLY	GPS input for a standalone RDS P.F. control system
GPS + AMATRON PLUS	Third-party interface: GPS input + <u>sending</u> Variable-rate Treatment (VRT) instructions to an OEM third-party rate controller.
GPS + BOGBALLE	
GPS + LH5000 v.4	
GPS + KVERNELAND	
GPS + RAVEN	
GPS + FIELDSTAR	
Bottom Port *	
NOT USED	Factory default setting
RDS PRINTER ICP200	Printing Field Summary data / Calibration data
PC DOWNLOAD	Output via cable to PC
RDS PF MODULE	Enables the internal Data Card Module Using an (older) external RDS Data Card Module
FIELDSTAR TYPE 1	Third-party interface: <u>Receiving</u> Variable-rate Treatment (VRT) instructions from an OEM third-party rate controller.
AGROCOM ACT	
YARA N-SENSOR	
JD GREENSTAR	
RAVEN 4800	
RAVEN 9600	

* **INSERTING A DATA CARD DISABLES THE BOTTOM PORT!**

Internal Data Card Module



Figure 37. SD Data Card Module

The internal data card reader accepts SD/MMC cards of up to 2Gb, to store data generated from harvesting, soil sampling, or variable-rate treatment. It can also upload data e.g. treatment plans or navigation data for soil sampling.

Typically, a 64Mb card can store data for up 2500 hectares.

Cards must have a directory called "**Rds_data.xxx**" in which all data is stored and retrieved. This directory should be automatically created when you first insert the card into the Data Module. All PF data is written to this directory. If the folder "Rds_data.xxx" is not created automatically, manually create it in the normal way from Explorer.

NOTE :The bottom port is disabled when an SD card is inserted in the internal data card module. On removing the card, the port will revert to the function configured on the PORT SETUP screen (Table 3).

GPS Receiver

1 'GPS 16' GPS Receiver

RDS's own GPS receiver for GPS position and speed

The receiver comes fitted with a magnetic base. Mounting on a plastic roof will require a metal base plate (not included) to be attached by suitable means. Run the combined antenna/power cable into the cab.

Connect the lead directly to the top port.

NOTE: The lead also powers the unit.

Pro-Series port settings:

Top Port: 'GPS ONLY'

GPS Baudrate: 9600

After the initial power-on, allow up to 5 minutes for the receiver to automatically establish its position. Subsequently the unit should establish position more quickly.

NOTE: The GPS icon at the top of the display indicates the status of the GPS signal.

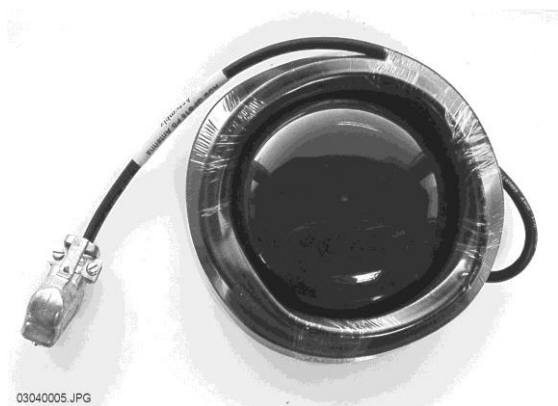

Figure 38. RDS GPS receiver

2 Third-party GPS Receivers

Any DGPS receiver may be used if the output is compatible with the head unit.

Changing the GPS baud rate.

Your existing GPS lead will not work if connected directly to the head unit. Connect it to the top port via the 'Pro-Series-Jupiter' lead Pt. No. S/CB/268-1-045.

NOTE 1: The GPS requires a separate power supply from a suitable switched-12V source.

NOTE 2: If sending VRT instructions to a third-party controller, the top port shares DGPS data in and VRT data out via a custom lead. Refer to section 6 for further information.

GPS Baud Rate

The RDS box needs to be configured as shown below to match the baud rate with the 3rd party GPS receiver to be compatible. The RDS Default = 4800.

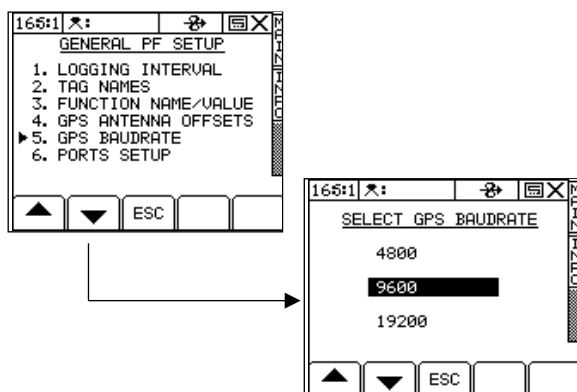

Figure 39. Baudrate setting

GPS Configuration

1 To enable the GPS to be used

From the main SETUP menu, select option 5. GENERAL PF SETUP.

Select 6. Ports Setup → using the arrow keys below the screen set the TOP PORT to 'GPS Only'.

If using an RDS GPS 16, select 5. GPS Baudrate and ensure that the baud rate is set to 9600. If a different GPS is being used then this speed must be established prior to configuration.



Figure 40. Enabling GPS

If the GPS is communicating correctly then a tick will be shown in the top header bar.

GPS Status:



= No position



= position/ no



diff.

Data Logging and Variable Rate Treatment

Data Logging and Variable Rate control functions are accessed from the SETUP screen.

1. Press the  key to display the logging screen (Fig.41).
The instrument then detects the presence of the data card.
2. Press the START key to select the JOB STARTUP page (Fig.42).

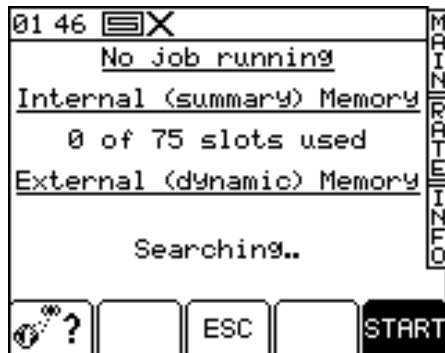

Figure 41. Logging screen

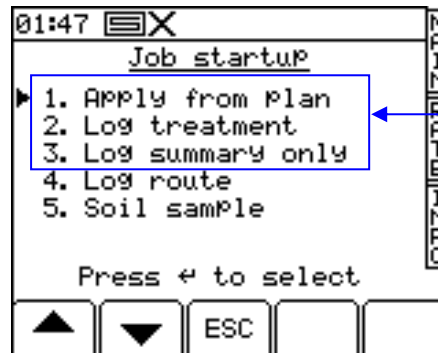

Figure 42. Startup page

Options applicable to Artemis

You are presented with a number of options. Only options 1,2 and 3 are applicable to the Artemis.

1. APPLY FROM PLAN (Variable-Rate Treatment or 'VRT')

- (a) The Pro-Series receives the rate from a treatment plan on the RDS Data Card Module and controls the application via the RDS control system. A full application record of the *actual* application is generated and saved on the Data Module.
- (b) The Pro-Series receives the rate from a treatment plan on the RDS Data Card Module and sends it to a third party controller, which controls the application via an OEM control system (System ERIS).
- (c) The Pro-Series receives the rate from a third-party controller and controls the application via the RDS control system (System ERIS). The Pro-Series can send back the actual application rate to the other controller

All setups allow the operator to commence a full VRT application.

For (a) and (b) a full application record of the *actual* application is generated and saved on the Data Module. The associated work record file can be viewed in the mapping/treatment plan software. Job summary data (iii) is also appended to the work record file.

2. LOG TREATMENT (Dynamic Data Logging)

A full application record is generated, logging rate and other parameters (e.g. "tags") in real time, attributing this data to a specific location. The associated "Dynamic Logging" file is viewed in the mapping/treatment plan software. A large amount of data is generated by dynamic logging and therefore must be saved onto an RDS Data Card Module. Job summary data (iii) is also appended to the dynamic logging file.

3. LOG SUMMARY ONLY (Field Data Logging)

For simple farm record keeping and traceability purposes, you can record a summary of each job or work session in the internal memory, and subsequently download directly to a PC, to a Data Module, or print to a printer. The amount of summary data for each job is small, and is saved in the internal memory. The instrument can store up to 75 individual job summaries.

Calibration Procedure

1. Open flap (1) to allow seed to flow out of the Air Transfer Pipe directly below the ORGA Metering Outlet.
2. Switch the scales ON and check units (kg). Zero the scales with the weight of the calibration bag and Hanger.
3. The calibration hanger and bag supplied with the DTS can then be hooked onto the Air Transfer Pipe. (See Right).



Caution! Always Prime the ORGA Metering Unit before Calibration

Press the Prime button fastened to the toolbox once. Then Press the button again at the point where seed flows evenly from the outlet. Empty contents of Calibration bag back into the hopper, Press ESC on Control Box, then proceed to step 4.

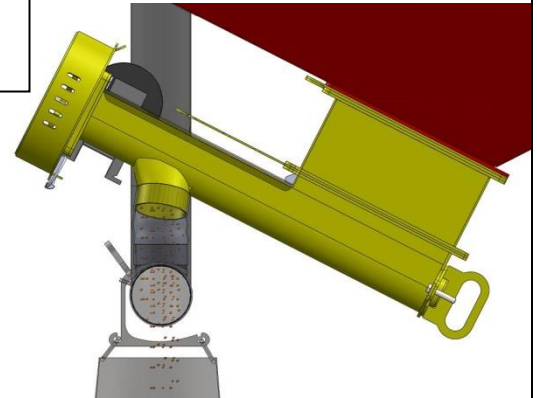
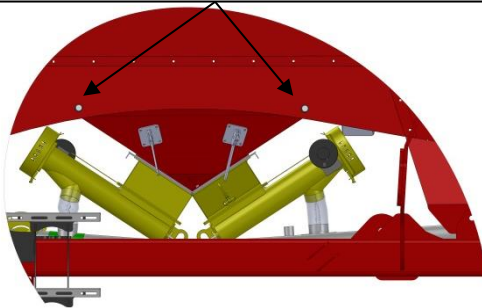
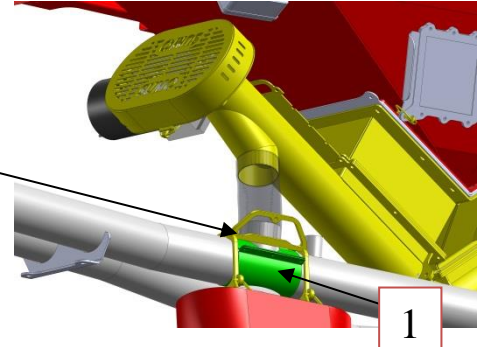

4. Press the white prime button once. This will put the control box in calibration mode and start the motor turning and metering seed.
5. Press the white prime button once again to stop the motor once a suitable sample is collected.
6. The seed dispensed out of the ORGA Metering Unit can be weighed using the digital weigh scales supplied with the drill.
7. Close Calibration flap (1) after last calibration procedure

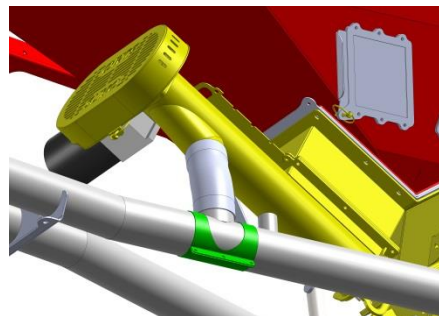
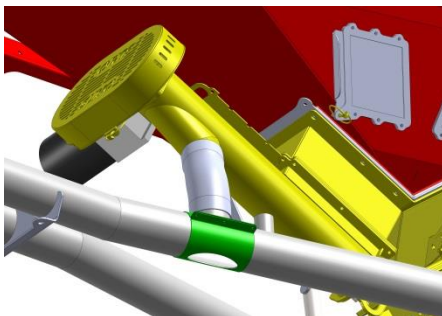

Ensure Calibration flap is shut after the calibration procedure.



NOTE: If a priming switch is deployed for calibration the calibration routine will commence.

- After the motor has been stopped with the white button the screen will show the expected weight.

Then enter the ACTUAL weight dispensed using the keypad (Fig.43) and press **ENTER** to confirm.

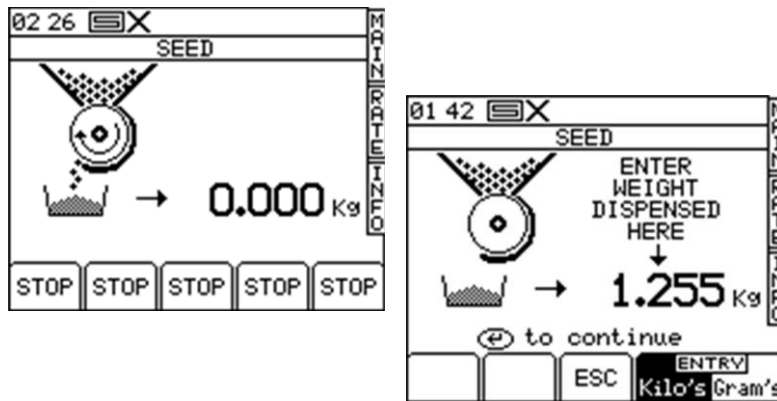

Figure 43. Screen appearance during calibration

NOTE: The heading will either be SEED / FERT / LEFT / RIGHT according to the drill setup

- Press **ENTER** again for the instrument to re-calculate and display the new calibration factor in kg/rev, the error %, and the maximum forward speed that is permissible based on the application rate set for the product (fig.44).

Figure 44. Newly calibrated data

- Press **ENTER again to confirm and store** the new calibration factor, or press ESC to return to the SETUP menu screen.
- This entire procedure should be repeated as many times as necessary until there is an acceptable error. (2 – 3 times is normally sufficient)

It is recommended to reset the PART TOTAL to zero before commencing drilling. This will enable you after drilling an area, to quantify any error in the calibration factor by logging the theoretical amount of product used against a known amount used (a whole bag for example).

7.3.1 ORGA Metering Setup

Before any calibration test is performed the ORGA Metering Unit must be set up for the seed required. Larger harder seeds like peas and beans do not require the nylon insert in the orga housing. This is simply removed by two bolts. The setup should be based on the required seed rate, working width of the drill as well as driving speed.

To ensure successful drilling, be sure to take into account the specific weight of the type of seed. It may also be beneficial to change the coulter outlets from the standard twin row tip to a single outlet type.

ORGA Metering Setup

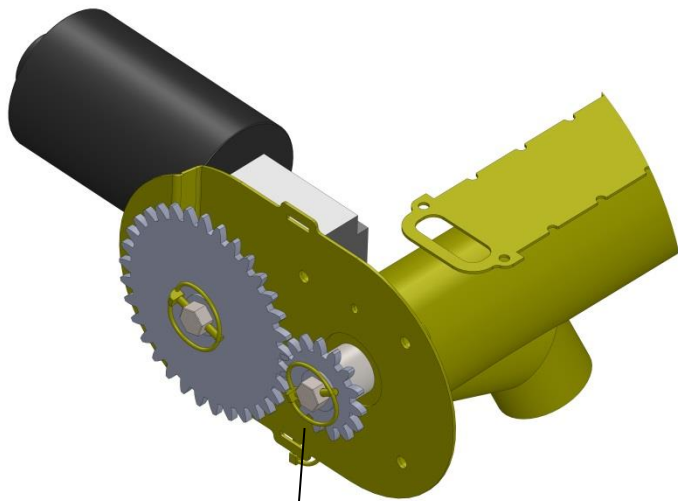

Gears are interchangeable between the Motor Shaft and Sumo ORGA shaft to achieve a wide range of seeding rates. E.g 3:1 gearing can be swapped to achieve 1:3. Each Metering Unit is supplied with a large and a small gear.



Agitation unit has two positions, 'in work' (illustrated) and 'out of work'. These positions are secured with a linch pin. The agitator should be used on notches 3 and 4 to combat possible bridging of seed, e.g. Grass seed.

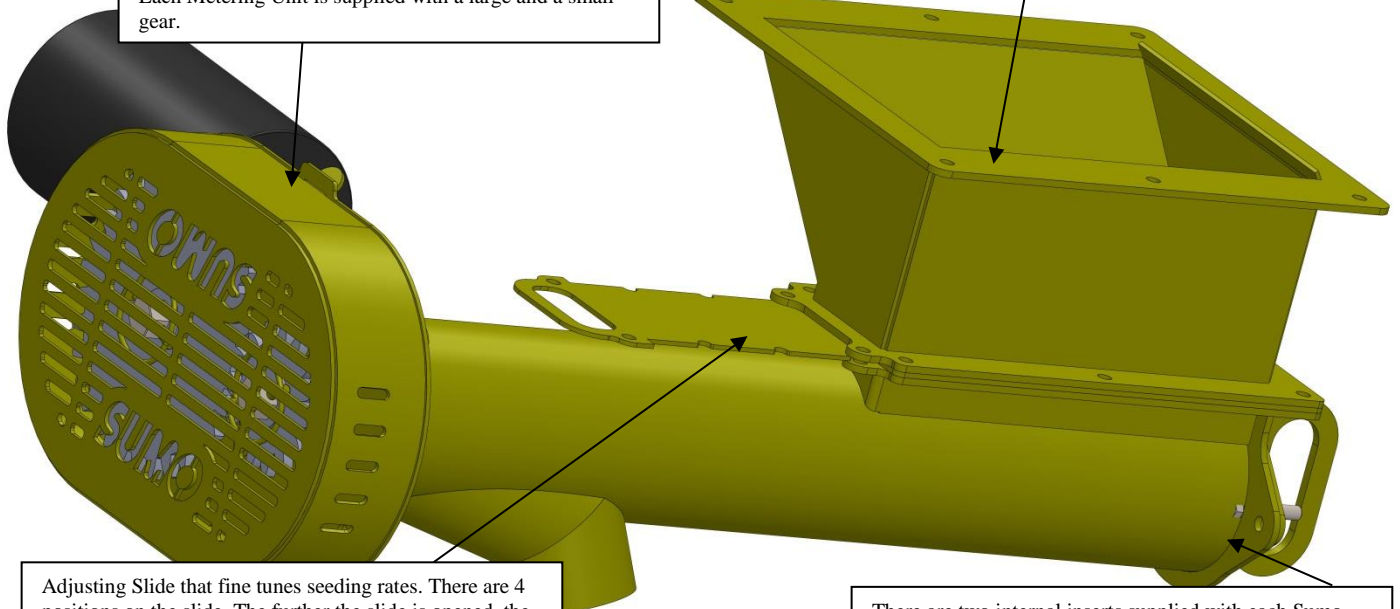

Adjusting Slide that fine tunes seeding rates. There are 4 positions on the slide. The further the slide is opened, the larger the inlet aperture thereby giving a larger seed rate. Please note that the further the slide is opened the larger the load on the motor. Where possible always use the lowest position possible without sacrificing speed or seed rate.

There are two internal inserts supplied with each Sumo ORGA. A long insert is used to reduce (approximately half) the seed rate for very low seed rates e.g. Oilseed Rape, Grass or Linseed. The inserts also act as a guide to align the Sumo ORGA. The Short Insert has no effect on seed rates and purely supports the end of the orga flighting.

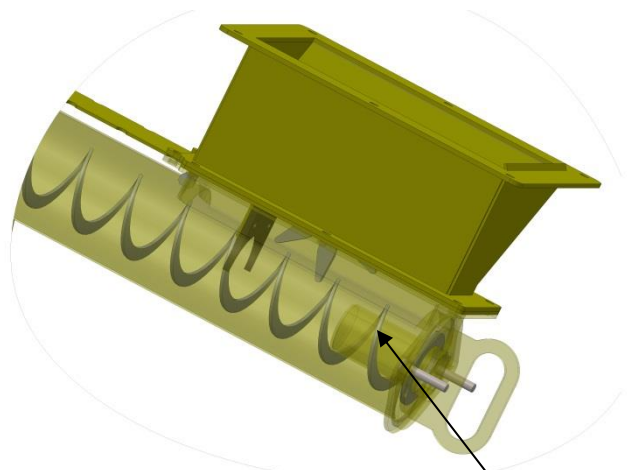
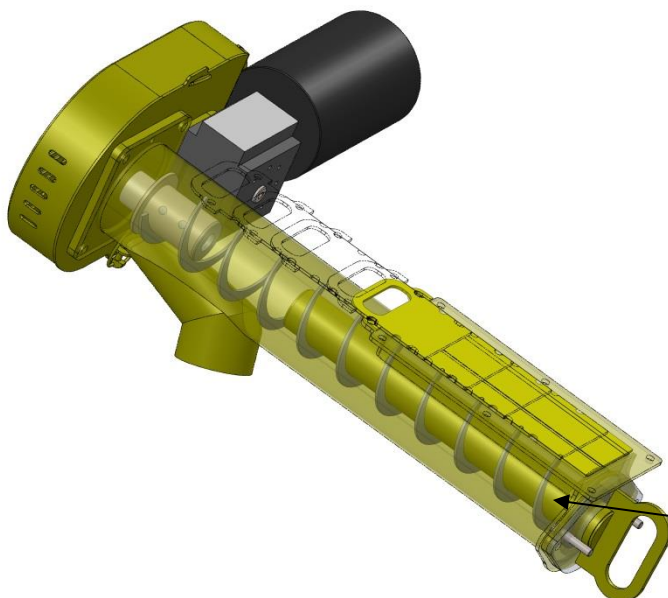

Large Insert

Short Insert

ORGA Metering Setup Overview

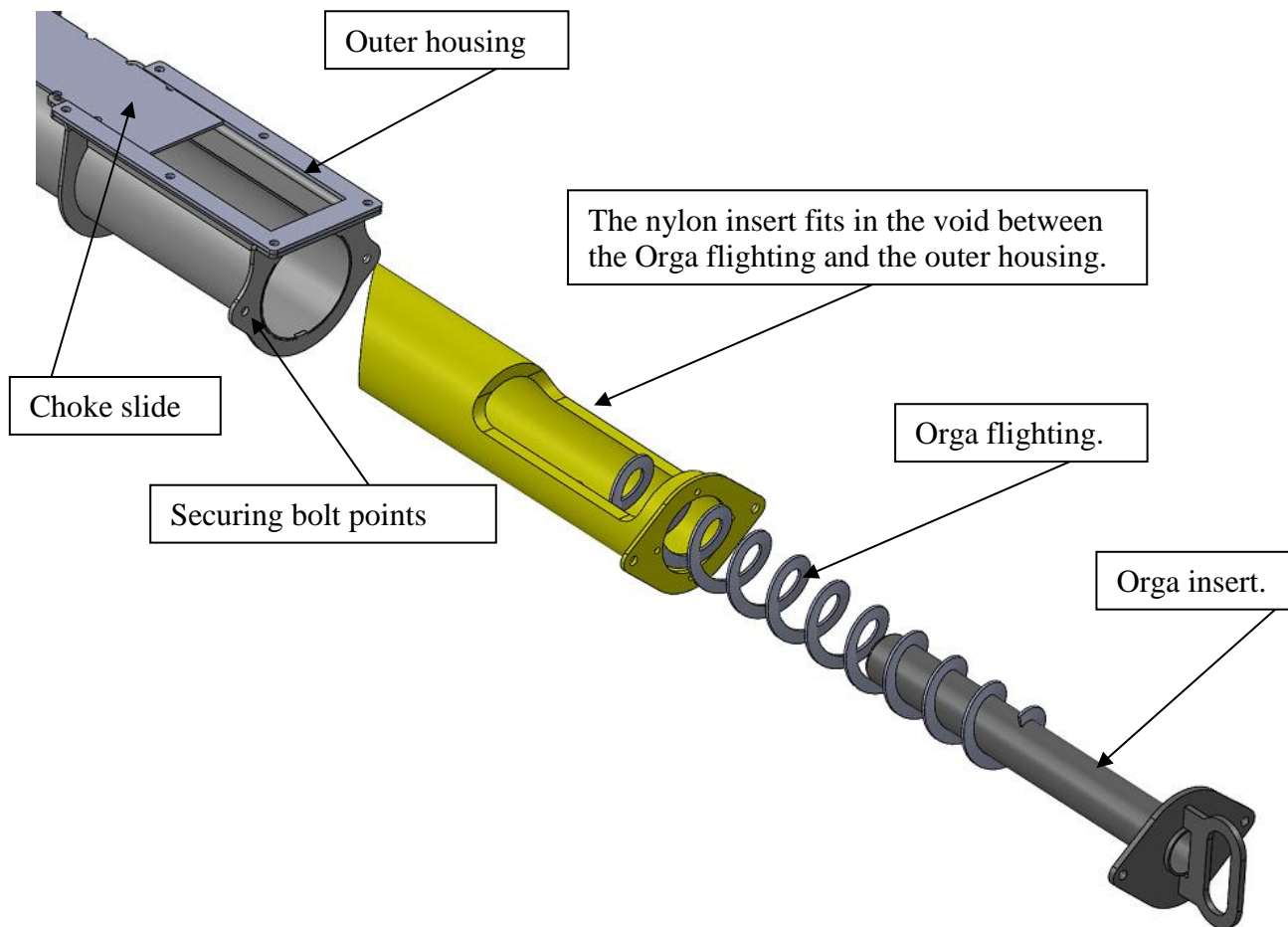

Up to 8m working widths it is recommended to operate the Orga metering unit with the nylon insert fitted for small seeds and cereals in order to prevent potential minor seedrate output fluctuations when drilling on gradients.

When drilling fertilizer, peas, beans and other similarly large and hard seeds, the insert should be removed. In this circumstance, the void is critical to allow smooth seed flow.

RDS Kit list and Part Numbers

Drill head unit



Item #	Part No.	Description	Qty
40	SWB314	Head Unit (S/HU/268-6-003)	1
41	SWB315	Cable - Head Unit (S/CB/268-6-045)	1
42	SWB316	Mounting Bracket Kit (S/PS/BKT/MK2)	1

Item #	Part No.	Description	Qty
1	SWB295	Motor Assembly (S/AC/268-6-043)	1
2	SWB296	CAN Module – MCM (S/HU/322-5-002)	1
3	SWB297	Wiring Harness – MCM (S/CB/322-5-021)	1
5	SWB298	Junction Box (S/AC/268-6-049)	(1 of 2)
6	SWB299	Sensor Kit – (for Seed Shaft) (K/SNR/503)	(2 of 4)
8	SWB300	Switch Kit – (for Priming - Product calibration)(K/ENT/SWCH)	1
9	SWB301	Magnet Carrier – (Seed Shaft) (S/MG/289-1-010)	2
10	SWB302	Blue Magnet - (Raise and lower) (S/MAGNET/002)	2
11	SWB303	Red magnet (Fan impeller) (S/MG/193-1-020)	2

Single Motor Drive – MCM related components



Single/Dual Motor Drive - HBM related components

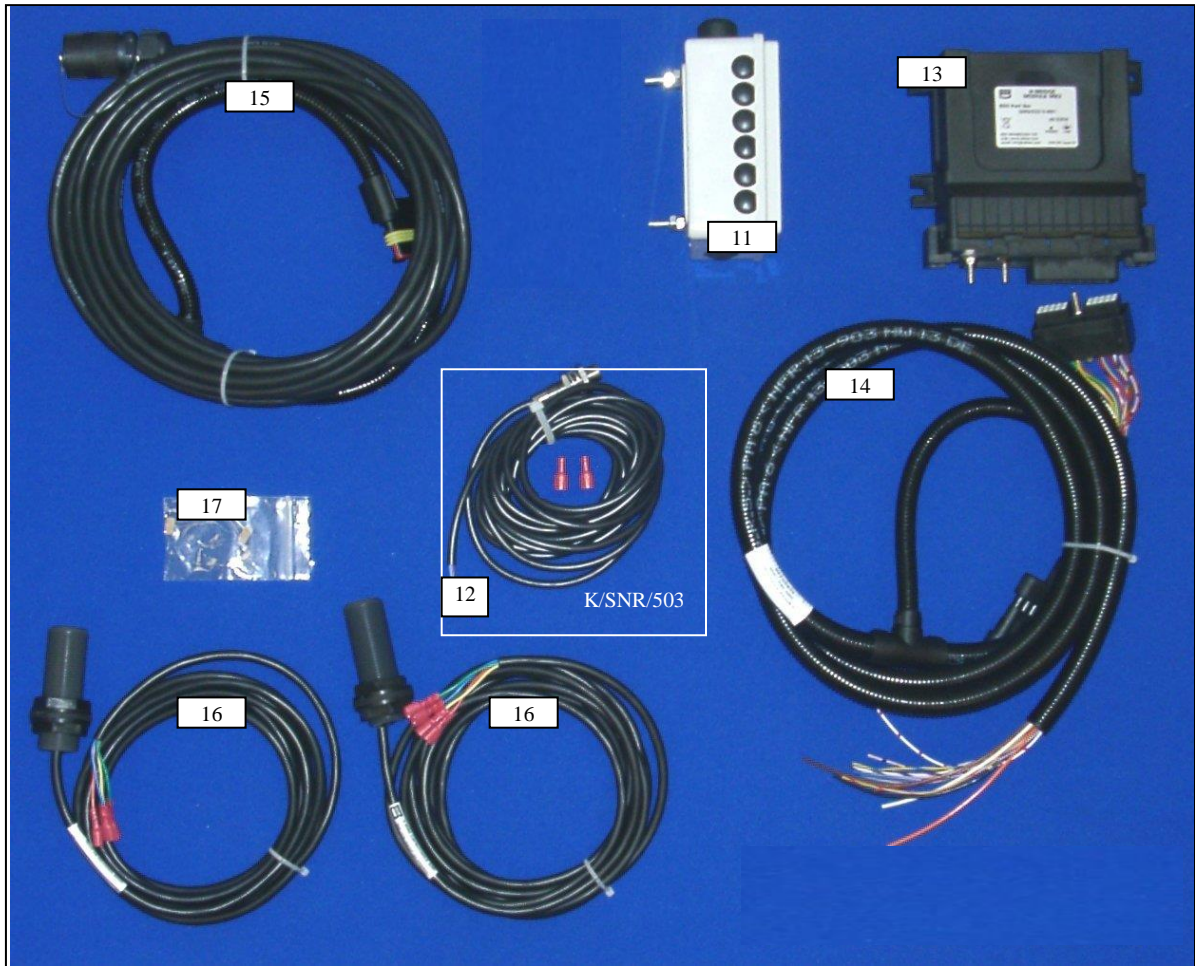

Item #	Part No.	Description	Qty
11	SWB298	Junction Box (S/AC/268-6-049)	(1of 2)
12	SWB299	Sensor Kit – (for Fan Shaft) (K/SNR/503)	(1 of 4)
13	SWB304	CAN Module – HBM (S/HU/322-5-001)	1
14	SWB305	Wiring Harness – HBM (S/CB/322-5-020)	1
15	SWB306	Wiring Harness - Main (S/CB/268-6-046)	1
16	SWB307	Sensor – (for Hopper Level) (S/SR/201-2-001)	2
17	SWB308	10K Resistor (S/R501-097)	2

Power Supply and Radar Sensor

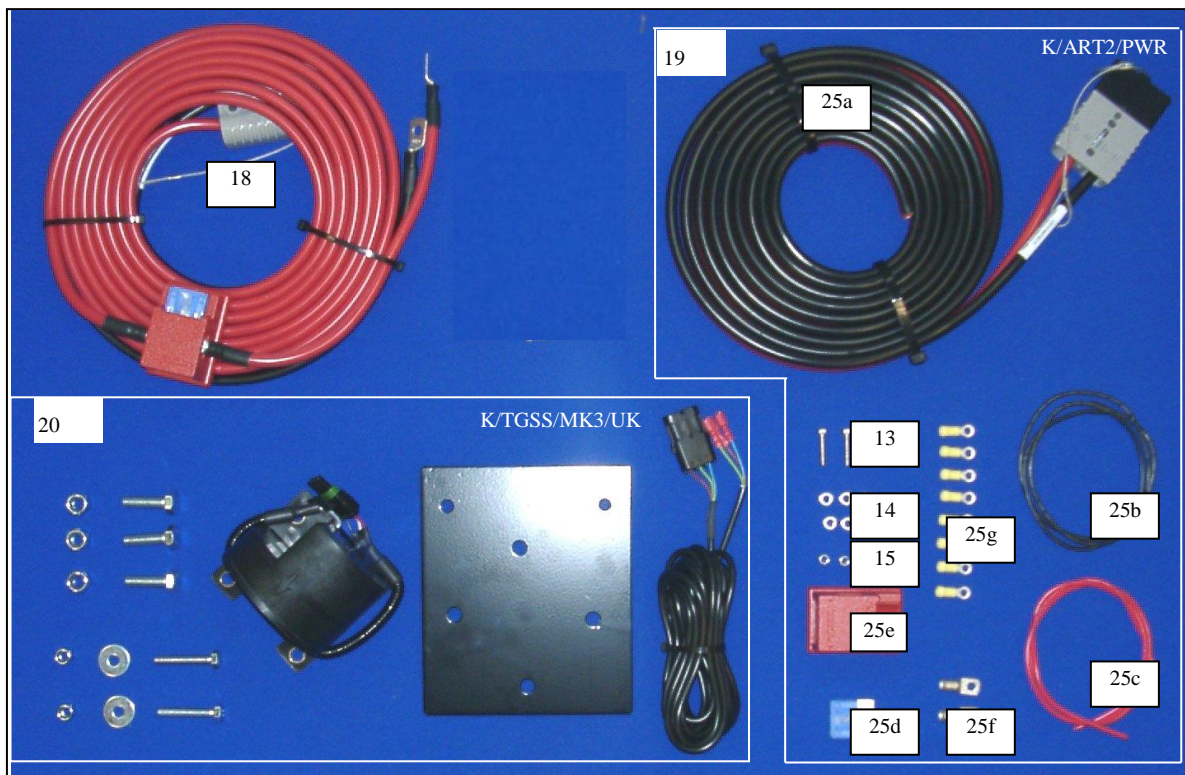

Item #	Part No.	Description	Qty
18	SW877	Power Cable – Tractor (S/CB/500-1-074)	1
19	SWB309	Power Supply Kit (K/ART2/PWR)	1
20	SWB310	Radar Sensor Kit (K/TGSS/MK3/UK)	1
25 e	SWB355	Power lead fuse holder (S/H661-012)	1
25 d	SWB363	60 amp fuse (S/H663-025)	1

Extension kit

A 4m extension cable kit for use with trailed drills

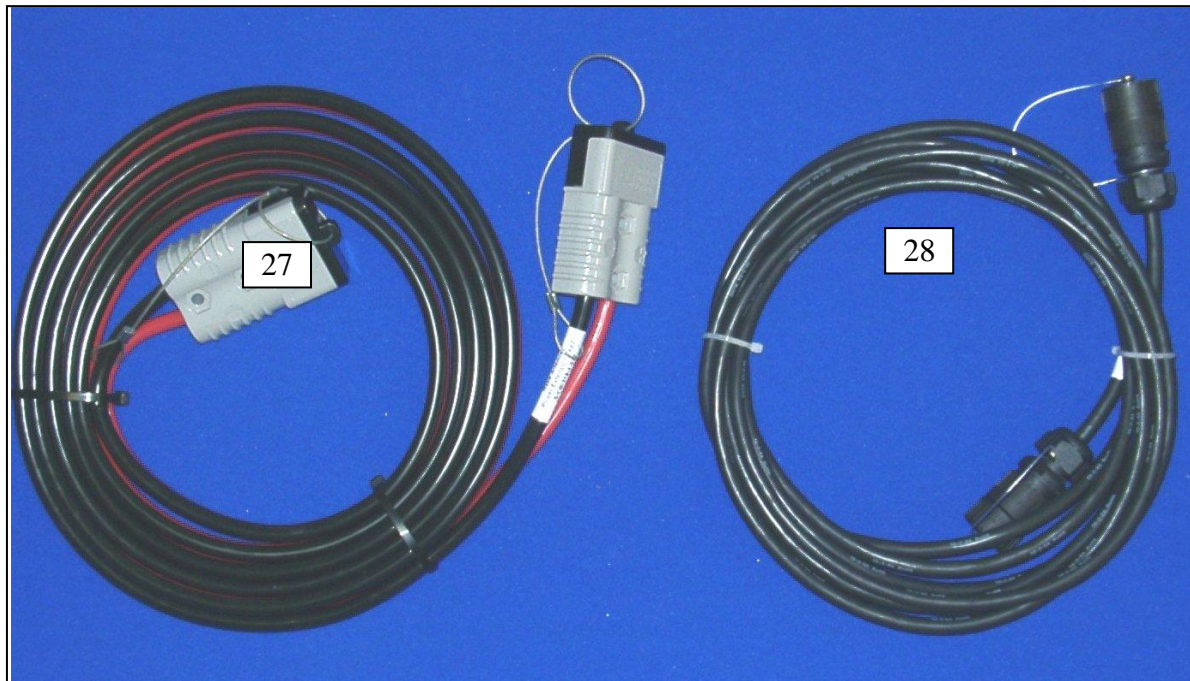

Item #	Part No.	Description	Qty
27	SW896	Power Supply Extension Cable – 4m (S/CB/318-1-022)	1
28	SW897	Instrument Extension Cable – 4m (S/CB/318-1-021)	1

Trailed Drill Settings



SAFETY NOTICE:
 Never operate Sumo ORGA Metering without gear guard in place.
 Never put any fingers into the Sumo ORGA Metering until unit is isolated from the power.
 Failure to do so may result in injury.



Crop	Rape	Rape	Grass	Linseed	Cereals	Cereals	Cereals	Cereals	Cereals	Beans****	Peas****
Drilling rate (kg/ha)	3	10	20	20	80	100	150	200	250	150	150/250
Insert *	Long	Long	Short	Short	Short	Short	Short	Short	Short	Short	Short
Notch**	1	1	3	3/4	3/4	4	4	4	4	3/4	3/4
Gear on Motor ***	Small	Small	Large	Small	Large	Large	Large	Large	Large	Large	Large
Gear on ORGA ***	Large	Large	Small	Large	Small	Small	Small	Small	Small	Small	Small
Min Fan speed (rpm)	1800	1800	1900	2200	2500	2600	2750	2900	3000	2500	2500

This table is to be used as a guideline to assist in setting up the drill. Fine tuning may be needed depending on environment.

* - Internal inserts are supplied in long and short lengths. The longer insert approximately halves the rate that the notched slide lets through its aperture. They also act as a guide to align the Sumo ORGA.

** - Notches are found on the adjustable rate slide. The Notches range from 1 to 4, and the more notches that are visible the higher the seed rate will be. Where possible, a smaller notch should be used to reduce motor loads if high drilling speeds are not necessary.

*** - The Gears supplied with the Sumo ORGA are specifically designed for the width of Drill that is specified. There will always be a small and a large gear supplied.

**** Nylon insert not to be used



3m Drill Settings



SAFETY NOTICE:
 Never operate Sumo ORGA Metering without gear guard in place.
 Never put any fingers into the Sumo ORGA Metering until unit is isolated from the power.
 Failure to do so may result in injury.



Crop	Rape	Rape	Grass	Linseed	Cereals	Cereals	Cereals	Cereals	Cereals	Beans****	Peas****
Drilling rate (kg/ha)	3	10	20	20	80	100	150	200	250	150	150/250
Insert *	Long	Long	Long	Long	Long	Long	Long	Long	Long	Short	Short
Notch**	2	2	4	2 or 3	4 or 5	3 or 4	3 or 4	4 or 5	4 or 5	3,4 or 5	4 or 5
Gear on Motor ***	Small	Small	Large	Small	Large	Large	Large	Large	Large	1:1 Gears	1:1 Gears
Gear on ORGA ***	Large	Large	Small	Large	Small	Small	Small	Small	Small	1:1 Gears	1:1 Gears
Min Fan speed (rpm)	1800	1800	1900	2200	2500	2600	2750	2900	3000	2500	2500

This table is to be used as a guideline to assist in setting up the drill. Fine tuning may be needed depending on environment.

* - Inserts are supplied in Long and Short lengths. The Longer insert approximately halves the rate that the Notched Slide lets through its aperture. They also act as a guide to align the Sumo ORGA.

** - Notches are found on the adjustable rate slide. The Notches range from 1 to 4, and the more notches that are visible the higher the seed rate will be. Where possible, a smaller notch should be used to reduce motor loads if high drilling speeds are not necessary.

*** - The Gears supplied with the Sumo ORGA are specifically designed for the width of Drill that is specified. There will always be a small and a large gear supplied.

**** Nylon insert not to be used



