



LOW DISTURBANCE SUBSOILER



2015 Operator Manual and Parts List



www.sumo1.com

Redgates
Melbourne
York
YO42 4RG
Tel. 01759 319900
Fax. 01759 319901

1.0 Registration

To activate your SUMO Warranty, you must complete this page and send it back to us at:

Sumo UK Ltd
Redgates
Melbourne
York
YO42 4RG
Tel. 01759 319900
Fax. 01759 319901

(NO REGISTRATION = NO WARRANTY)

SUMO SERIAL No:

For your own records.

(Serial plate on side of headstock)



LDS Registration Document

NAME:

ADDRESS:

Postcode:

Telephone Number:

DATE:

SUMO SERIAL No.

(Serial plate on side of headstock)

DEALERSHIP
NAME AND
BRANCH:

COMMENTS:



In order to obtain your free pair of Sumo overalls and baseball cap please fill in this form and send back to us at:

Sumo UK Ltd
Redgates
Melbourne
York
YO42 4RG
Tel. 01759 319900
Fax. 01759 319901



SUMO SERIAL No:

Overall size:
tick where applicable

Small (38 chest)	<input type="checkbox"/>
Medium (42 chest)	<input type="checkbox"/>
Large (46 chest)	<input type="checkbox"/>
Extra large (50 chest)	<input type="checkbox"/>
XX Large (54 chest)	<input type="checkbox"/>
XXX Large (58 chest)	<input type="checkbox"/>

NAME:

ADDRESS



2.0 Summary

The SUMO Low Disturbance Subsoiler has been developed to alleviate compaction in the subsurface region of most soil types. The design of the LDS enables this lift and fracture to be carried out whilst creating minimal surface disturbance.

When used in conjunction with the Sumoseeder the LDS becomes an effective tool for the establishment of OSR and other small seed crops.

Firstly

A leading row of straight serrated discs cut through any surface trash eliminating any build up around the following subsoiler legs. The discs have adjustable depth positions which are easily altered via a one-bolt system.

Secondly

The subsoiler legs then lift and fracture the soil alleviating any compaction. The legs are manufactured from 20mm Hardox 500, and have a pin adjustable depth of between 4”- 14” deep. The legs are available with either shear pin or hydraulic auto reset protection.

Finally

There are 4 choices of packer for the LDS

F Type Flat shark fin packer ensures important surface aeration across the full working width of the machine.

T Type packer utilising pneumatic tractor tread tyres which are positioned to run directly behind each leg firming up the area around the slot made by the subsoiler leg.

R Type packer similar to the patented Sumo multipacka again designed to consolidate the soil behind the subsoiler leg.

M Type packer is the patented Sumo mulitpacka

Before using the SUMO LDS it is absolutely necessary that you read this Operators Manual and Safety Instructions attentively.

Specifications, descriptions and illustrations in this brochure are accurate, as known, at the time of publication but may be subject to change.



Table of Contents

1.0 Registration	...Page 1
2.0 Summary	...Page 3
3.0 Safety	...Page 5
3.1 Qualification and Training	...Page 5
3.2 General Safety	...Page 6
3.3 Special Safety Instructions	...Page 6
3.4 Risk Assessment	...Page 7
4.0 Operation and Adjustment	...Page 8
4.1 Operation	...Page 8
4.2 Adjustments	...Page 8
4.3 Auto Reset Legs	...Page 8
5.0 Maintenance	...Page 9
5.1 Spares	...Page 9
5.2 Winter Storage	...Page 9
6.0 Parts and Assembly	...Page 10
6.1 Single Disc Unit	...Page 10
6.2 Front Disc Angle Adjustment	...Page 11
6.3 Packer Assembly	...Page 12
6.4 Packer Depth Assembly	...Page 13
6.5 Scraper Assembly	...Page 14
6.5.1 Flat Roller Scraper	...Page 14
6.5.2 Ringed Roller Scraper	...Page 15
6.5.3 Double Ringed Roller Scraper	...Page 16
6.6 Auto Reset Assembly	...Page 17
6.7 Leg and Point Assembly	...Page 18
6.8 Arable Leg Assembly	...Page 19
6.9 Light Assembly	...Page 20
6.10 Main Frame Headstock	...Page 21
6.11 Folding	...Page 22
6.12 Stickers and Paint	...Page 23

3.0 Safety

This manual contains basic advice which should be observed during setting-up, operation and maintenance. Therefore, this operating manual must be read by the personnel concerned prior to starting up, using the machine and be available at all times.

If safety instructions are not complied with, then this can lead to the risk of injury to yourself and others as well as damage to the environment or the machine. Non-compliance to the safety instructions can also lead to claims for damages becoming invalid.

3.1 Qualification and Training

- Ensure that only reliable, authorized personnel work on or with the machine. Statutory minimum age limits must be observed.
- Employ only trained or instructed staff; the individual responsibilities of the personnel concerning operation, setting up, maintenance and repair must be clearly established.
- Define the machine operators' responsibilities – also with regard to observing traffic regulations. The operator must have the authority to refuse any instructions issued by third parties, which contravene safety.
- Persons undergoing training or instruction or taking part in a general training course should not be allowed to work on or with the machine unless they are under the constant supervision of an experienced person.
- The use of spare parts, accessories and ancillary equipment not supplied and/or not approved by SUMO could have detrimental effects to the construction of the SUMO machine or on its functions and hence impair the active and/or passive driving and/or operational safety (accident prevention).
- SUMO shall not be responsible for any damage caused by the use of spare parts, accessories and ancillary equipment not supplied and/or approved by SUMO.
- Conversions of or modifications to the machine may only be carried out after consultation with SUMO.

3.2 General safety

- Warning signs and other notices on the machine provide important information for the safe operation. Observing them will serve your safety.
- Before starting work, make yourself familiar with all the equipment and controls as well as their functions.
- The user should wear close-fitting clothing.
- Keep the machine and in particular the bearings clean to avoid risk of fire.
- Check around the machine before moving off or starting up (watch out for children!). Make sure you have adequate all-round visibility.
- Always match your speed to the local conditions. Avoid sudden turning manoeuvres when driving uphill or downhill or when travelling across a slope.
- Observe the respective regulations when using public roads.
- Take into account the wide overhang and/or the sideways force acting on the machine when turning or negotiating curves.

3.3 Special safety instructions

- Take extreme care when hitching up or unhitching machine to/from the tractor.
- Never allow persons to stand between the tractor and the machine unless the tractor is secured against rolling away by means of parking brake and/or wheel chocks.
- During transport, secure the packer (using both pins) to prevent shock loading when encountering road undulations. Ensure stands are raised to their transport position.
- It is forbidden to allow persons to ride on the machine at any time. A safe distance should be maintained from the machine by observers when in work.
- Driving, steering and braking characteristics are influenced by mounted machines and ballast weights. Therefore, ensure adequate steering and braking ability.
- Never stand or work beneath suspended loads. Ensure stands are in position before commencing maintenance work.
- When making adjustments to the machines care should be taken not to trap any body parts in moving or pivoting parts.

Model: Low Disturbance Subsoiler

Year: 2014



3.4 RISK ASSESSMENT

Date assessment written: 22nd April 2014

Assessor: R. A. Hight

Notes: Ensure the operator manual is read and fully understood.

Purpose of machine: Primarily designed to alleviate compaction and improve soil structure with minimal surface disturbance.

Description of machine: A three-point-linkage mounted farm implement consisting of 3 major elements.

1. A row of rubber suspended, straight, notched discs.
2. A bank of staggered low disturbance subsoiler legs.
3. A toothed roller, optionally followed by a scarifying harrow.

All of the above is arranged in a heavy duty fabricated steel framework.

The Machine is designed to couple to a suitably powered tractor.

Hazard identified in using machine	Who might be harmed	Risk evaluation/level 1-5	Precautions in place	Further action required
Machine collision while in transport.	Operator, members of the public	2 - low_med	Tail lights, reflectors.	Take care when using in both field and road situations. Maintain good visibility at all times.
Trapped fingers during leg depth position change.	Operator	1 - low	Warnings, maintenance stands	Observe warning signs, maintain safe distance from moving parts, wear gloves. Ensure both of the stands are down. Clear excess soil (weight) from points before attempting to adjust legs.
Risk of crushing: - When coupling a tractor to the Sumo implement. - When changing points.	Operator	4 - med_high	Warnings, maintenance stands	Take extreme care when working on legs, changing depth, replacing points etc, make sure stands are down and the machine is on a suitable firm piece of land. Ensure tractor hydraulics are in good working order. Ensure tractor is safely positioned and the parking brake is engaged when coupling up to the Sumo implement.
Falling from machine	Operator	2 - low_med	Most alterations and maintenance do not require the operator the climb on the machine. If a seeder is fitted, then steps and a handrail will also be fitted to allow access.	Lower the machine to the floor to allow access for greasing discs, checking bearings etc...

4.0 Operation and Adjustment

4.1 Operation

Before attaching the Low Disturbance Subsoiler to a tractor is essential that the **stands are in the down position** to ensure a short top link once attached. Once attached securely to the tractor the machine can then be raised and the stands lifted out of the way. When the machine is removed from the tractor it is equally as important to leave the machine on the stands.

Due to the physical nature and weight distribution of the Sumo LDS **a category three enclosed ball top link** is highly recommended as the best option for dealing with the exaggerated loads experienced during normal working conditions.

The top link should be as short as possible whilst remaining as close to horizontal as is achievable. In the majority of cases this means using the bottom hole on the Subsoiler and the top hole on the tractor. It is important to ensure the machine is running level to allow the optimum level of soil disturbance as well as to prolong the life of the wearing parts.

Changing the points on the LDS must only be done on level ground. When it is deemed necessary to change the points, the stands should be lowered to the static position and other appropriate jacks, stands and chocks put into position in sensible locations. To avoid the risk of sinking and potential injury it is important to only change the points where ground conditions permit, i.e. solid concrete, tarmac etc. Care should be taken to ensure the LDS is firmly and safely held before changing the points. The tractor engine must be turned off with the parking brake applied.

Bearings should be greased (see section 5.0 Maintenance); stands must be in the raised position and all relevant pins in the correct holes prior to commencing work.

Forward working speed should be governed by the local conditions as well as the finish produced by the Sumo LDS.

4.2 Adjustments

Depth adjustment of the Subsoiler legs on the LDS is achieved by removing the lynch pin and depth pin then lifting or lowering the leg by the handle at the top and replacing the pin in the appropriate hole. The maximum leg depth is 350mm.

To adjust the working depth, the weight must first be taken off the packer arms before the lynch pins and depth pins are removed. A new depth position can then be selected by replacing the pins in higher or lower holes.

DO NOT TIGHTEN POINTS UP WITH AIR RACHETS OR OVER TIGHTEN WITH SPANNERS. EXCESSIVE TIGHTENING WILL RESULT IN POINTS CRACKING

4.3 Auto Reset hydraulic circuit

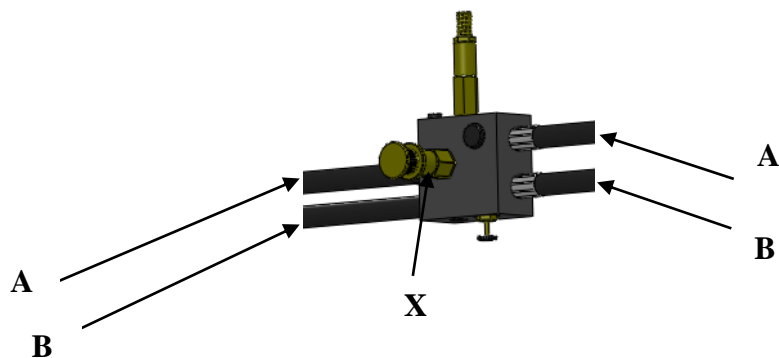
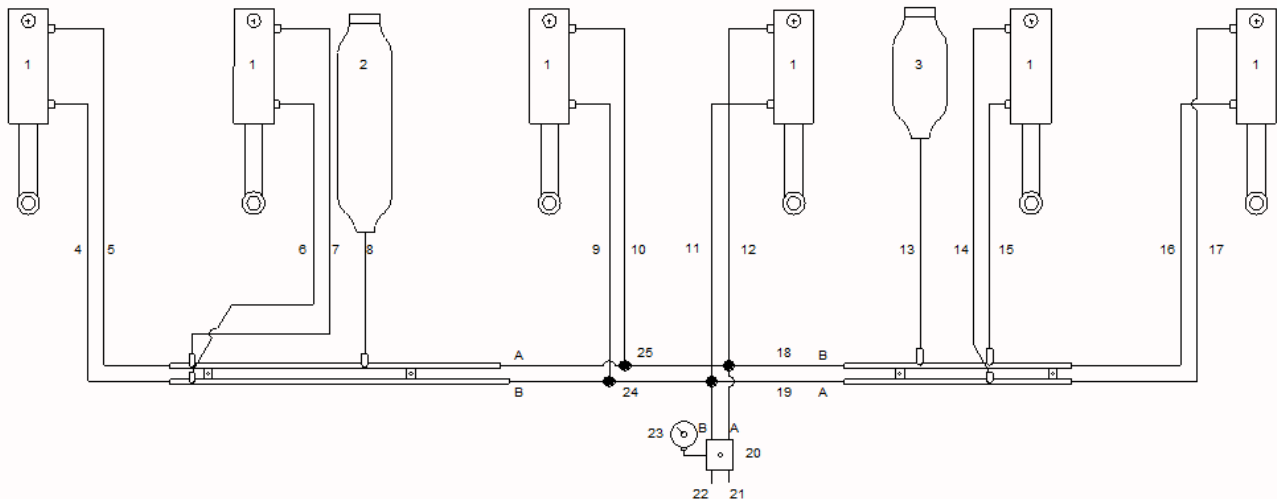

- 1) To lift the legs up and out of the work position; pressurize line B (the lower of the two hoses entering the valve block & marked "B" on the valve itself). The legs will lift as oil is returned to the tractor through Line A.
- 2) To lower the legs back down and into the work position; pressurize line A, the legs will lower one by one. Keep pumping until all of the legs come to a stop at the end of their stroke. Keep pumping for a few more seconds and the two lines will then pressure up. Keep an eye on the gauge on the right hand side of the machine as this displays the leg trip resistant pressure. The system needs then to be put into the "float" or pressureless state between the tractor and the valve so that any back pressure from the tractor does not affect the preset valve pressures. Putting the system into "float" means the factory set pressure readings of 80bar on the full bore side of the ram (gauge on RHS of machine) and 20bar on the rod side of the ram. This is unless of course they have been adjusted to suit local conditions. The resistant pressure is adjustable up to a maximum of 150bar
- 3) To increase the trip resistance of the legs – the knob marked X should be wound in. The lift and lower process should then be repeated.

5.0 Maintenance

The packer bearings should be greased with one pump once a week and after washing off.

The disc bearings should be greased until old grease is forced out once a week when in normal use and after washing off.

The condition of the subsoiler legs, the points and the discs should be regularly monitored in order to maintain the most efficient use of the machine.

The condition and position of the packer scrapers should also be observed in order to prevent soil building up on the packer. Ensure the scrapers are not touching the packer though, as this will add rolling resistance as well as causing premature wear of the packer.

Auto Reset - Grease points can be found on all rams on auto reset machines. These require one pump of grease every 50 hours. Exposed chrome ram rods should also be greased at the end of each season to prevent these valuable parts from rusting and causing costly oil leaks.

5.1 Spares

When ordering replacement parts please have your serial number, part numbers (listed in Section 6.0) and quantities at hand.

5.2 Winter storage

When machines are to be parked up for the winter period, correct storage techniques are an important part of protecting the machine to ensuring a hassle free season. When the machine has finished work it should be cleaned down and washed off to remove all traces of soil.

After washing the Sumo LDS, the packer bearings should be greased with one pump and the disc bearings should be greased until old grease is forced out. Other grease points are located on all rams on auto reset machines and these should receive two or three pumps of grease.

When the machine is parked up a note should be made of what wearing parts require replacing ready for the next seasons work. The wearing parts can then be ordered in time ready for the next season's work in good time to avoid delays when the machine is required earlier than expected!

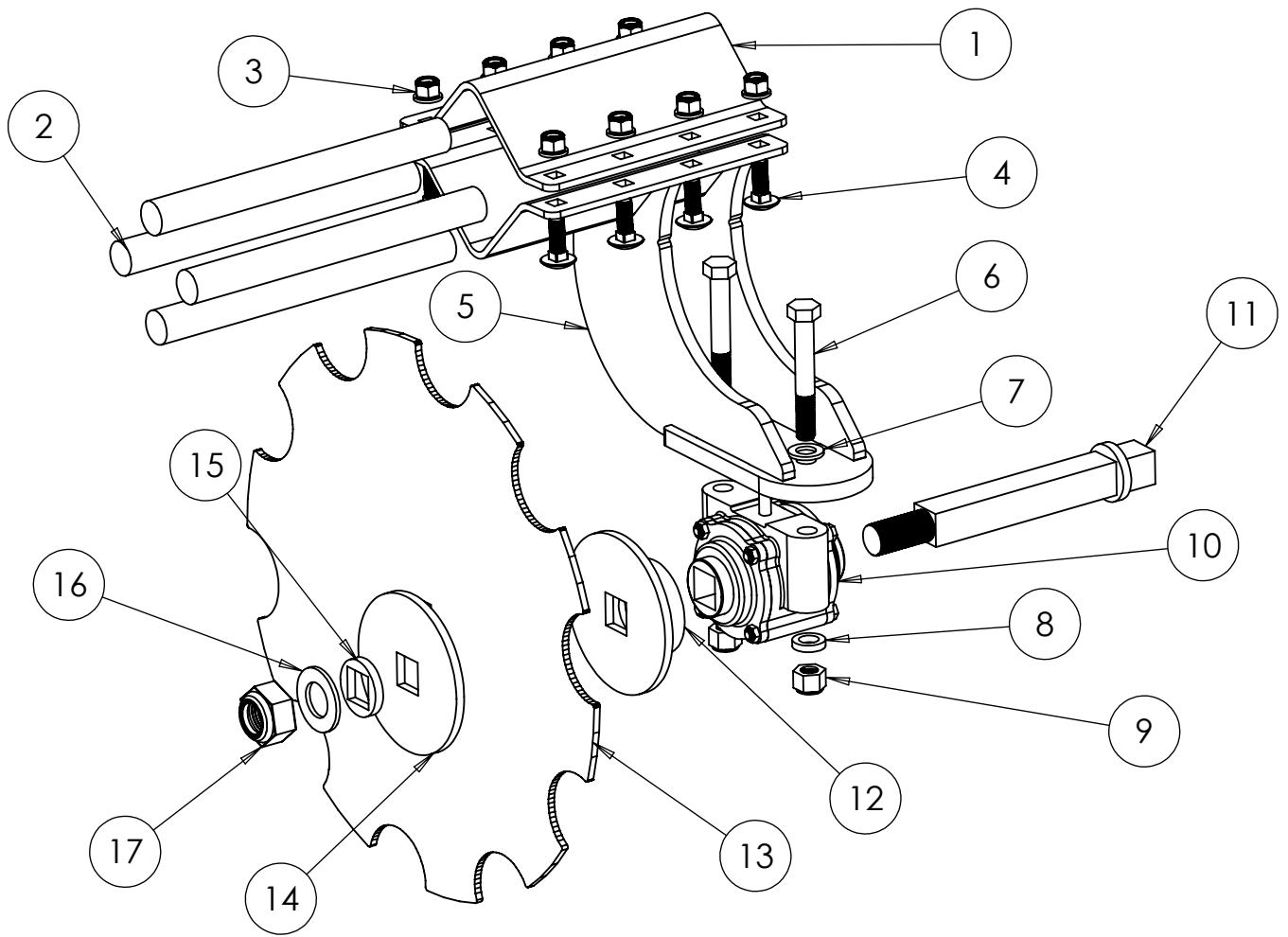

ITEM NO.	PART NO.	DESCRIPTION	QTY.
1	SW107	Clamp Plate	1
2	SWB103	Rubber	4
3	SWM12005	M12 Flanged Nut	8
4	SWM1235CHSQ	M12 x 35 Cup Head Square	8
5	SW547	Straight Disc Arm	1
6	SWM16110	M16 x 110 Bolt	2
7	SWM16001	M16 Washer	2
8	SW1153	M16 Thick Washer	2
9	SWM16004	M16 Nylock Nut	2
10	SWB102	Disc Bearing	1
11	SW1429	Single Disc Axle	1
12	SW546	Flat Washer and Dust Cover	1
13	SWB164	20" Straight Disc	1
14	SW548	Large Flat Washer	1
15	SW104	Small Washer	1
16	SWM30001	M30 Washer	1
17	SWM30004	M30 Nylock Nut	1

DO NOT SCALE DRAWING

MACHINE/COMPONENT:

LDS

TITLE:

Single Disc Unit



Drawings and design information found herein remain the sole property of Sumo UK Ltd. Reproductions may only be made with the permission of the owner.

SCALE: 1:10

REVISION:

DATE: 24/04/14

INITIAL: TW

6.2 Front Disc Angle Adjustment

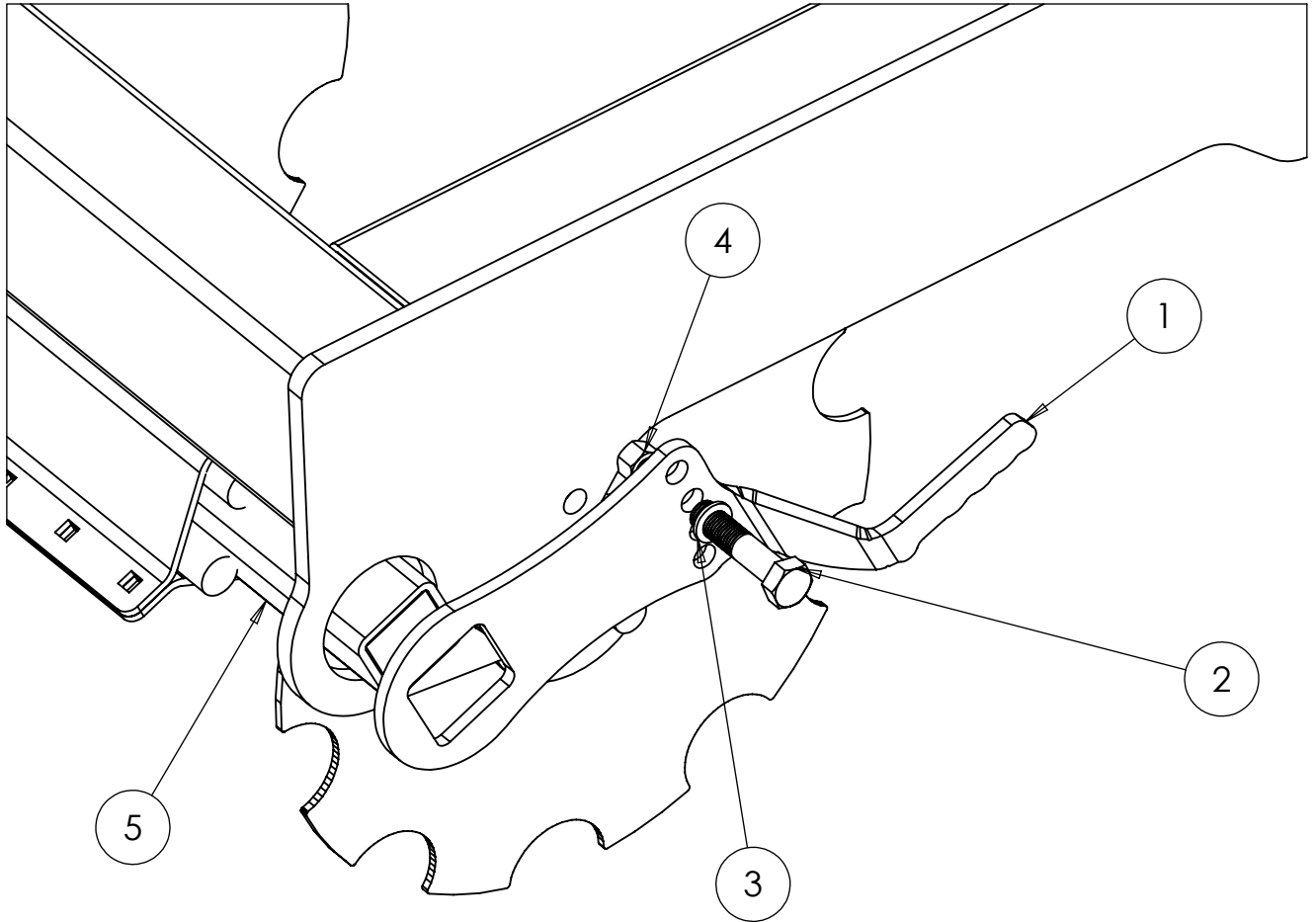

ITEM NO.	PART NO.	DESCRIPTION	QTY.
1	SW763	Front Disc Angle Arm	1
2	SWM1650	M16 x 50 Bolt	1
3	SWM16001	M16 Washer	2
4	SWM16004	M16 Nylock Nut	1
5	SW1548	3m Front Disc Bar	1

DO NOT SCALE DRAWING	
MACHINE/COMPONENT:	LDS
TITLE:	Front Disc Angle Adjustment
	
<small>Drawings and design information found herein remain the sole property of Sumo UK Ltd. Reproductions may only be made with the permission of the owner.</small>	
SCALE 1:5	REVISION:
DATE: 24/04/14	INITIAL: TW

6.3 Packer Assembly

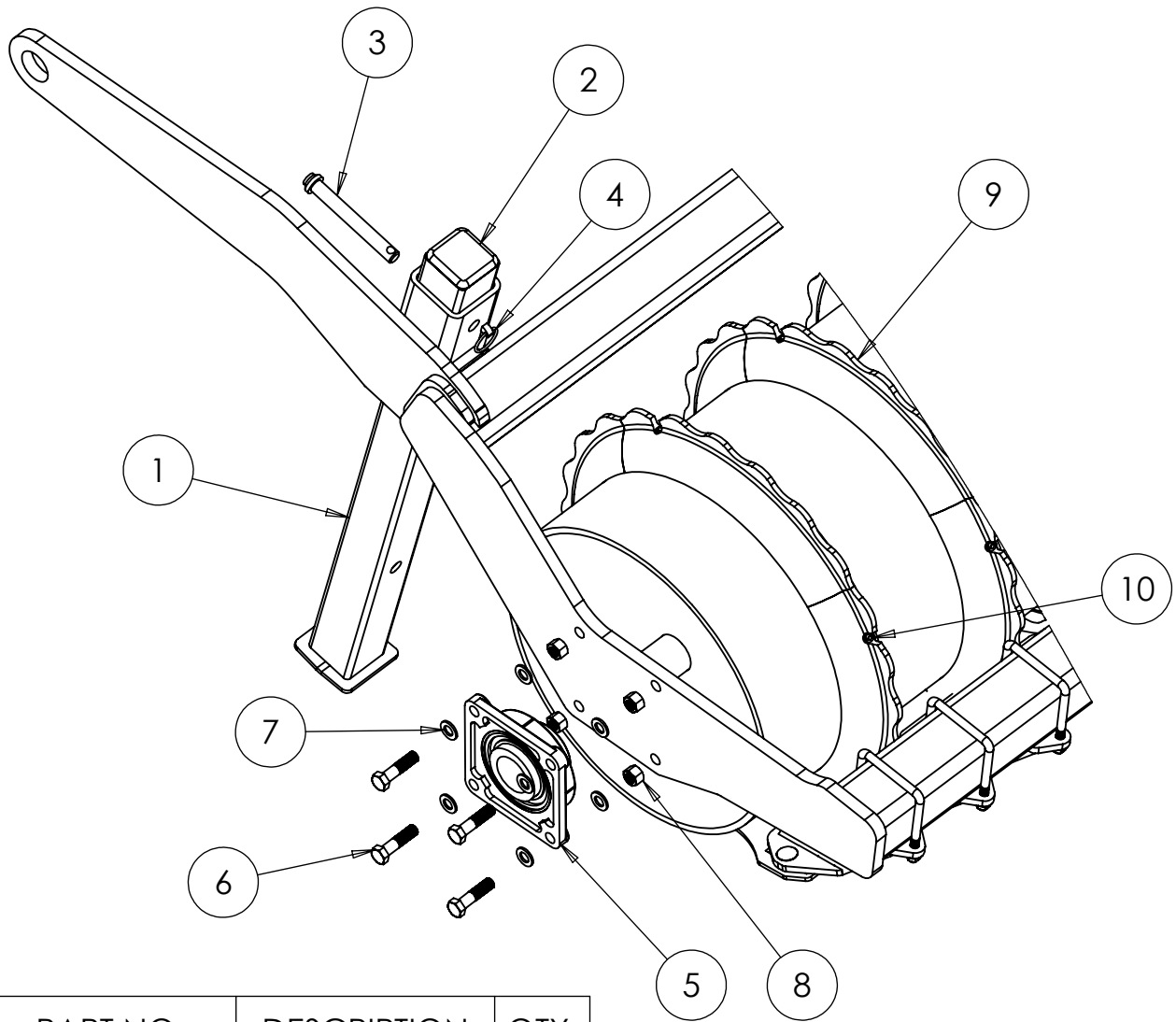

ITEM NO.	PART NO.	DESCRIPTION	QTY.
1	SW753	Rear Stand	2
2	SWB144	Rubber Stand Cap	2
3	SW118	Stand Pin	2
4	SWB105	Lynch Pin	2
5	SWB104	Packer Bearing	2
6	SWM1665	M16 x 65 Bolt	8
7	SWM16001	M16 Flat Washer	16
8	SWM16004	M16 Nylock Washer	8
9	SWB331	Packer Quadrant	44
10	SWM1240CH	M12 x 40 Cap Head Bolt	44
11	SWS4950	Weld on Tooth for Flat Packer (not shown)	36

DO NOT SCALE DRAWING

MACHINE/COMPONENT:

LDS

TITLE:

Packer Assembly



Drawings and design information found herein remain the sole property of Sumo UK Ltd. Reproductions may only be made with the permission of the owner.

REVISION:

DATE: 16 September 2014

INITIAL: TW

6.4 Packer Depth Assembly

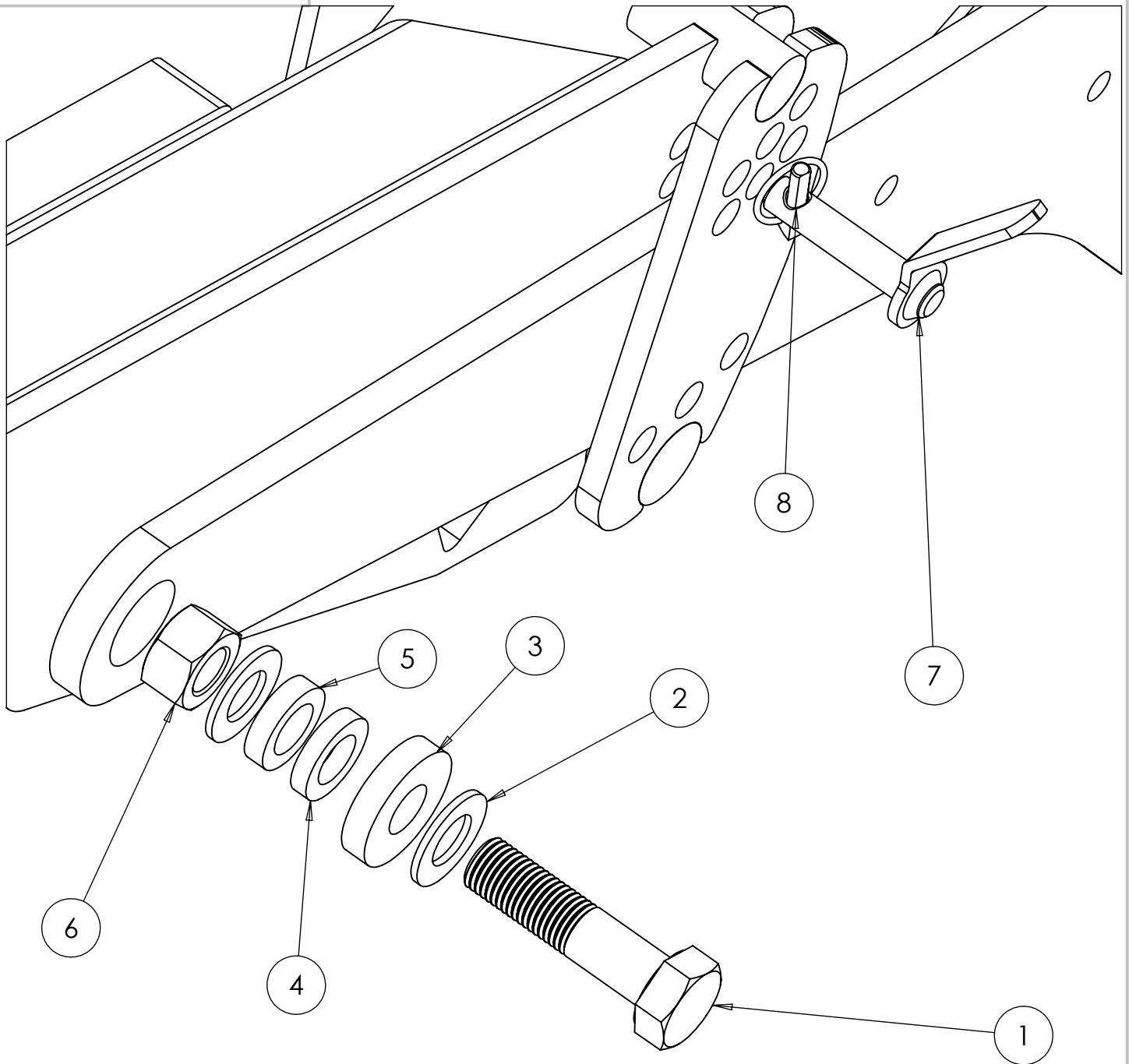

ITEM NO.	PART NO.	DESCRIPTION	QTY.
1	SWM30110	M30 x 110 Bolt	1
2	SWM30001	M30 Washer	2
3	SW129	15mm Large Washer	1
4	SW722	10mm Small Spacer	1
5	SW723	12mm Small Spacer	1
6	SWM30004	M30 Nylock Nut	1
7	SW130	Packer Depth Pin	1
8	SWB105	Lynch Pin	1

DO NOT SCALE DRAWING

MACHINE/COMPONENT:

LDS

TITLE:

Packer Depth Assembly



Drawings and design information found herein remain the sole property of Sumo UK Ltd. Reproductions may only be made with the permission of the owner.

SCALE 1:3

REVISION:

DATE: 24/04/14

INITIAL: TW

6.5 Double Ringed Scraper & Hanger Assembly

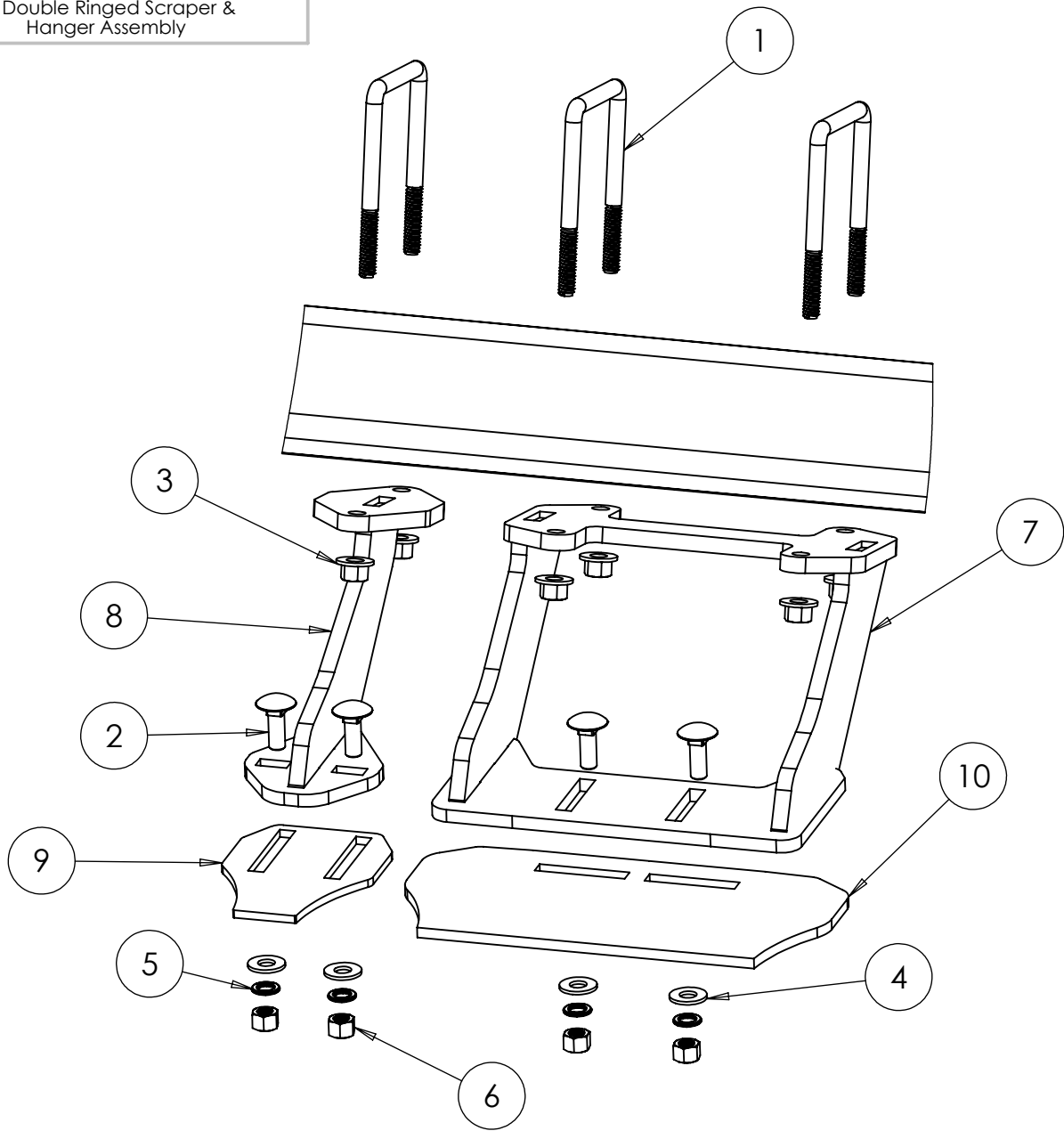

ITEM NO.	PART NO.	DESCRIPTION	QTY.
1	SWM12100ub	M12 x 100 U Bolt	3
2	SWM1235CHSQ	M12 x 35 Cup Head Square	4
3	SWM12004	M12 Nylock Nut	6
4	SWM12001	M12 Flat Washer	4
5	SWM12002	M12 Spring Washer	4
6	SWM12003	M12 Plain Nut	4
7	SW1549	Large Scraper Hanger	1
8	SW1967	Small Scraper Hanger	1
9	SW1053	Small Scraper	1
10	SW1975	Large Scraper	1

DO NOT SCALE DRAWING

MACHINE/COMPONENT: LDS - Double Ringed Roller

TITLE:

Scraper Assembly



Drawings and design information found herein remain the sole property of Sumo UK Ltd. Reproductions may only be made with the permission of the owner.

SCALE: 1:5

REVISION:

DATE: 03/09/14

INITIAL: TW

6.5 Ringed Roller Scraper & Hanger

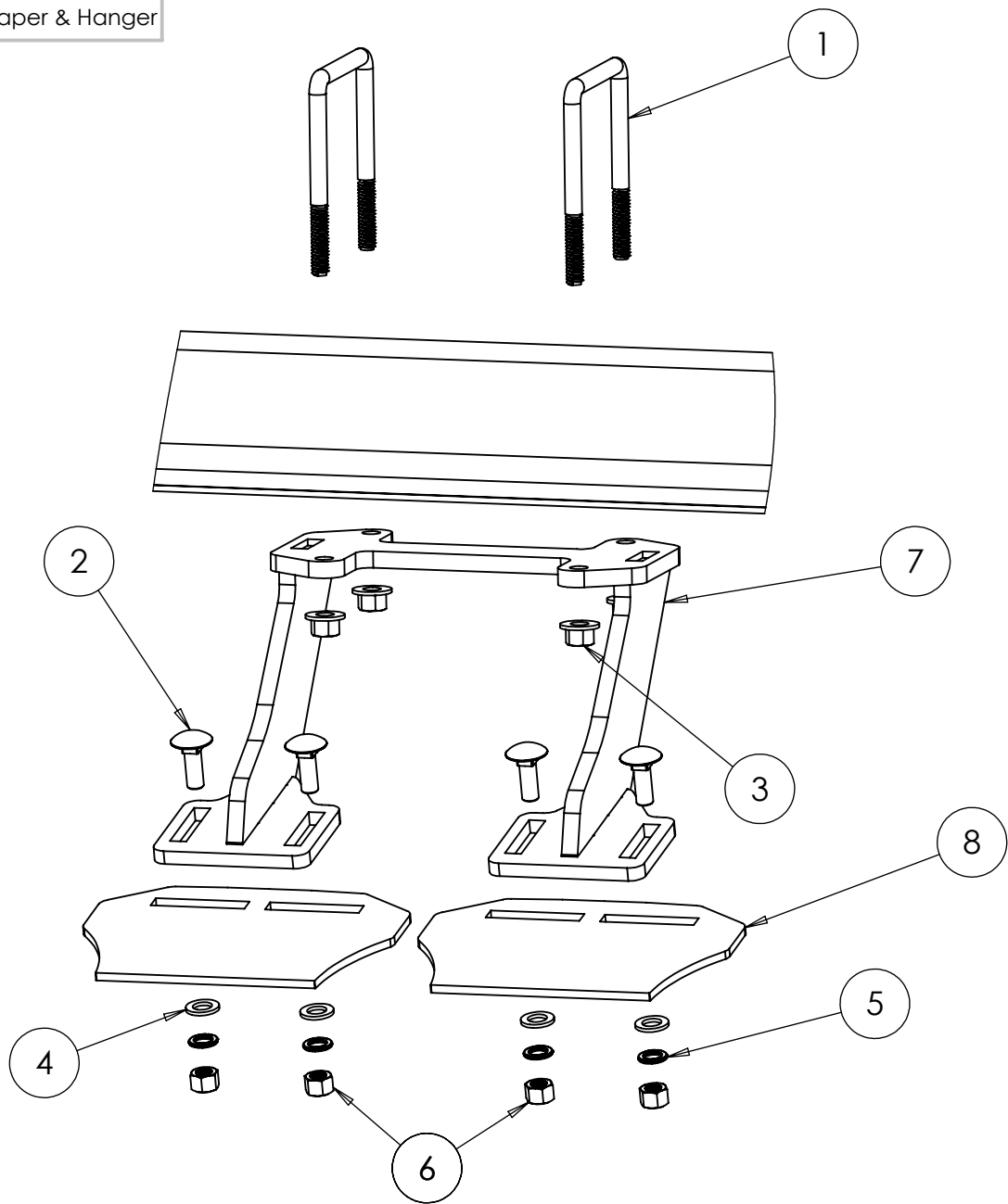

ITEM NO.	PART NO.	DESCRIPTION	QTY.
1	SWM12100ub	M12 x 100 U Bolt	2
2	SWM1235CHSQ	M12 x 35 Cup Head Square Bolt	4
3	SWM12004	M12 Nylock Nut	4
4	SWM12001	M12 Flat Washer	4
5	SWM12002	M12 Spring Washer	4
6	SWM12003	M12 Plain Nut	4
7	SW1044	Double Scraper Hanger	1
8	SW1043	Scraper	2

DO NOT SCALE DRAWING

MACHINE/COMPONENT:

LDS - Ringed Roller

TITLE:

Scraper Assembly



Drawings and design information found herein remain the sole property of Sumo UK Ltd. Reproductions may only be made with the permission of the owner.

SCALE: 1:5

REVISION:

DATE: 03/09/14

INITIAL: TW

6.5 Flat Roller Scraper & Hanger

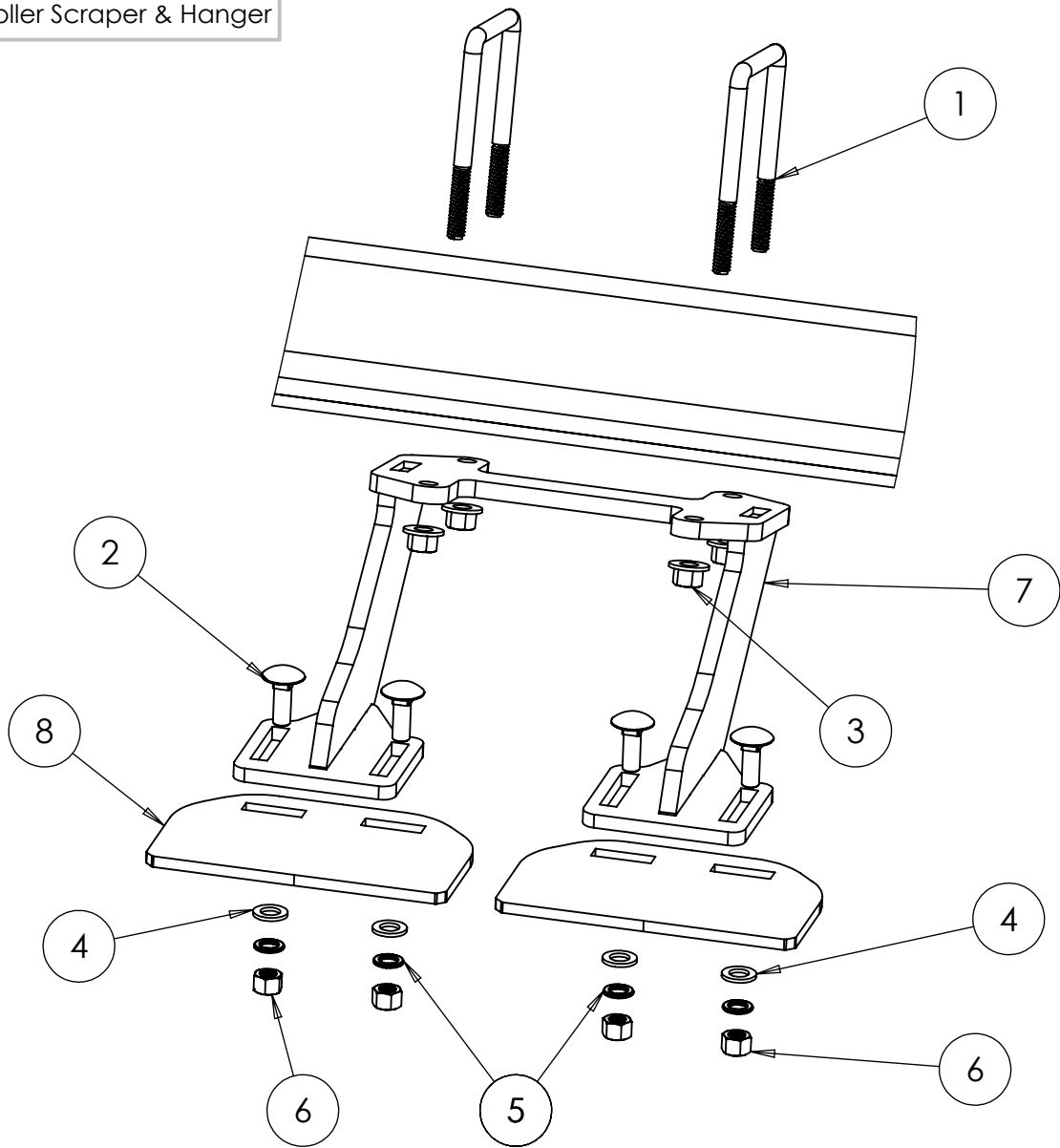

ITEM NO.	PART NO.	DESCRIPTION	QTY.
1	SWM12100ub	M12 x 100 U Bolt	2
2	SWM1235CHSQ	M12 x 35 Cup Head Square Bolt	4
3	SWM12004	M12 Nylock Nut	4
4	SWM12001	M12 Flat Washer	4
5	SWM12002	M12 Spring Washer	4
6	SWM12003	M12 Plain Nut	4
7	SW1044	Double Scraper Hanger	1
8	SW1976	Scraper	2

DO NOT SCALE DRAWING	PRE
MACHINE/COMPONENT: LDS - Flat Roller Packer	
TITLE: Scraper Assembly	
	
<small>Drawings and design information found herein remain the sole property of Sumo UK Ltd. Reproductions may only be made with the permission of the owner.</small>	
SCALE: 1:5	REVISION:
DATE: 02/09/14	INITIAL: TW

6.6 Auto Reset Assembly

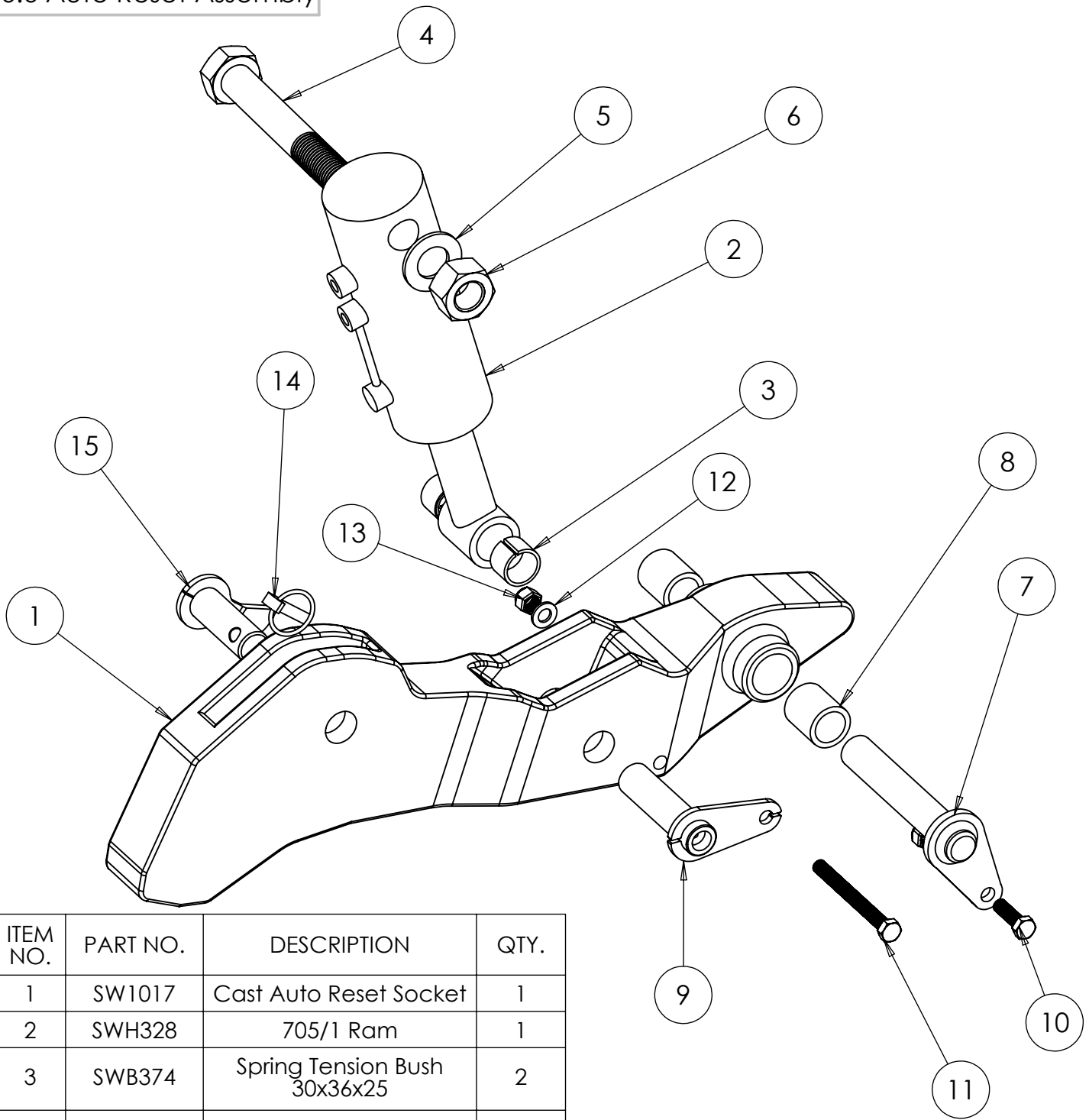

ITEM NO.	PART NO.	DESCRIPTION	QTY.
1	SW1017	Cast Auto Reset Socket	1
2	SWH328	705/1 Ram	1
3	SWB374	Spring Tension Bush 30x36x25	2
4	SWM30200	M30 x 200 Bolt	1
5	SWM30001	M30 Washer	1
6	SWM30004	M30 Nylock Nut	1
7	SW183	30mm x 170mm Tabbed Pin	1
8	SW188	PB1 Bush 30x40x45	2
9	SW1192/ SW1192R	30mm x 120mm Tabbed Grease Pin c/w grease nipple	1
10	SWM1240	M12 x 40 Bolt	1
11	SWM12130	M12 x 130 bolt	1
12	SWM12001	M12 Washer	2
13	SWM12004	M12 Nylock Nut	2
14	SWB105	Lynch Pin	1
15	SW451	Leg Depth Pin	1

DO NOT SCALE DRAWING

MACHINE/COMPONENT:

LDS

TITLE:

Auto Reset Assembly



Drawings and design information found herein remain the sole property of Sumo UK Ltd. Reproductions may only be made with the permission of the owner.

Scale 1:5

REVISION:

DATE: 24/04/14

INITIAL: TW

6.7 Leg and Point Assembly

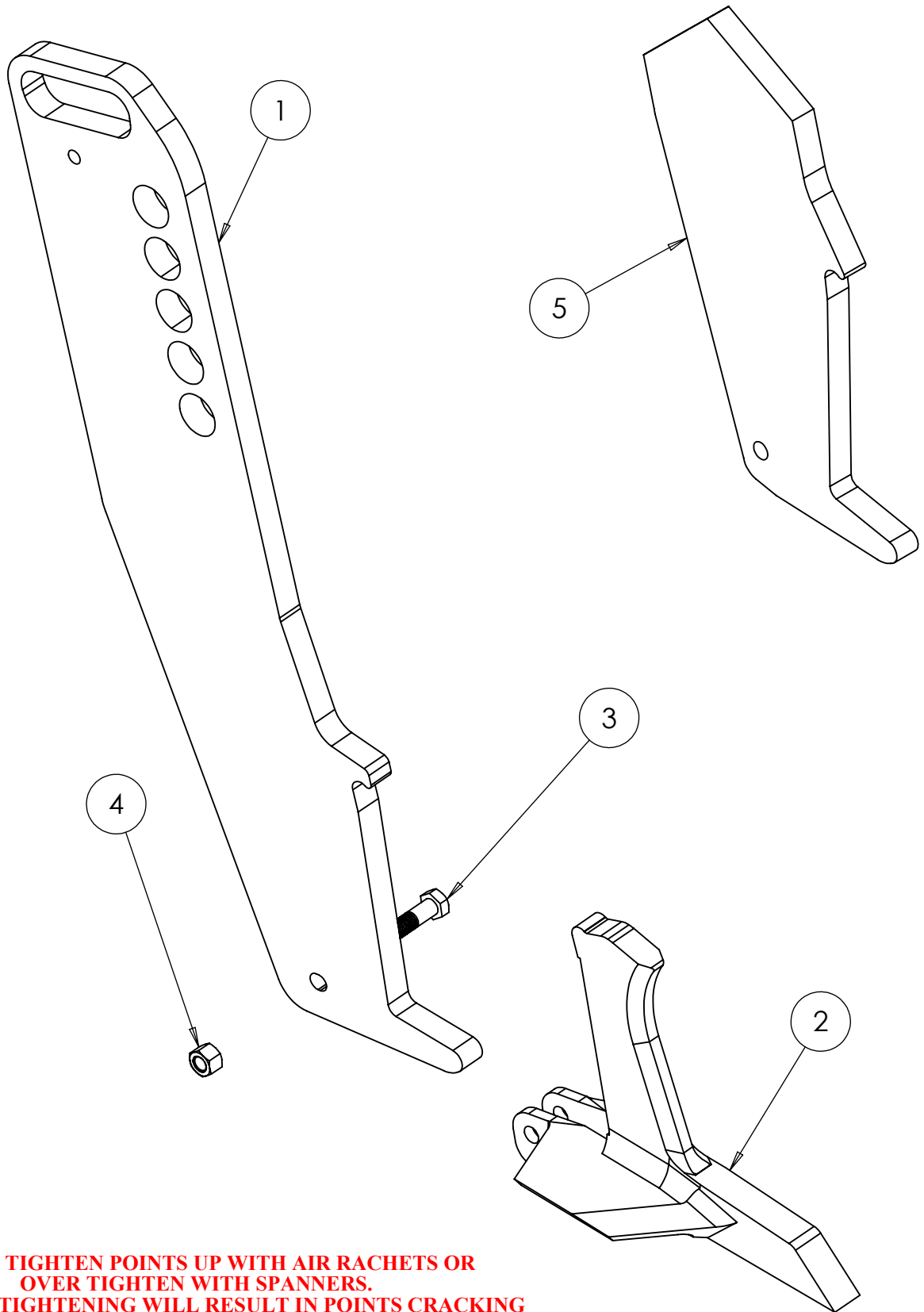

**DO NOT TIGHTEN POINTS UP WITH AIR RACHETS OR
OVER TIGHTEN WITH SPANNERS.
EXCESSIVE TIGHTENING WILL RESULT IN POINTS CRACKING**

ITEM NO.	PART NO.	DESCRIPTION	QTY.	DO NOT SCALE DRAWING	
1	SW1151	Leg	1	MACHINE/COMPONENT: LDS	
2	SW1116	Cast Point	1	TITLE: Leg and Point Assembly	
3	SWM1250	M12 x 50 Bolt	1	 Drawings and design information found herein remain the sole property of Sumo UK Ltd. Reproductions may only be made with the permission of the owner.	
4	SWM12004	M12 Nylock Nut	1		
5	SW1173	Weld on Leg Bottom	1	SCALE 1:4	REVISION:
				DATE: 26/10/12	INITIAL: TW

6.8 Arable Leg Assembly

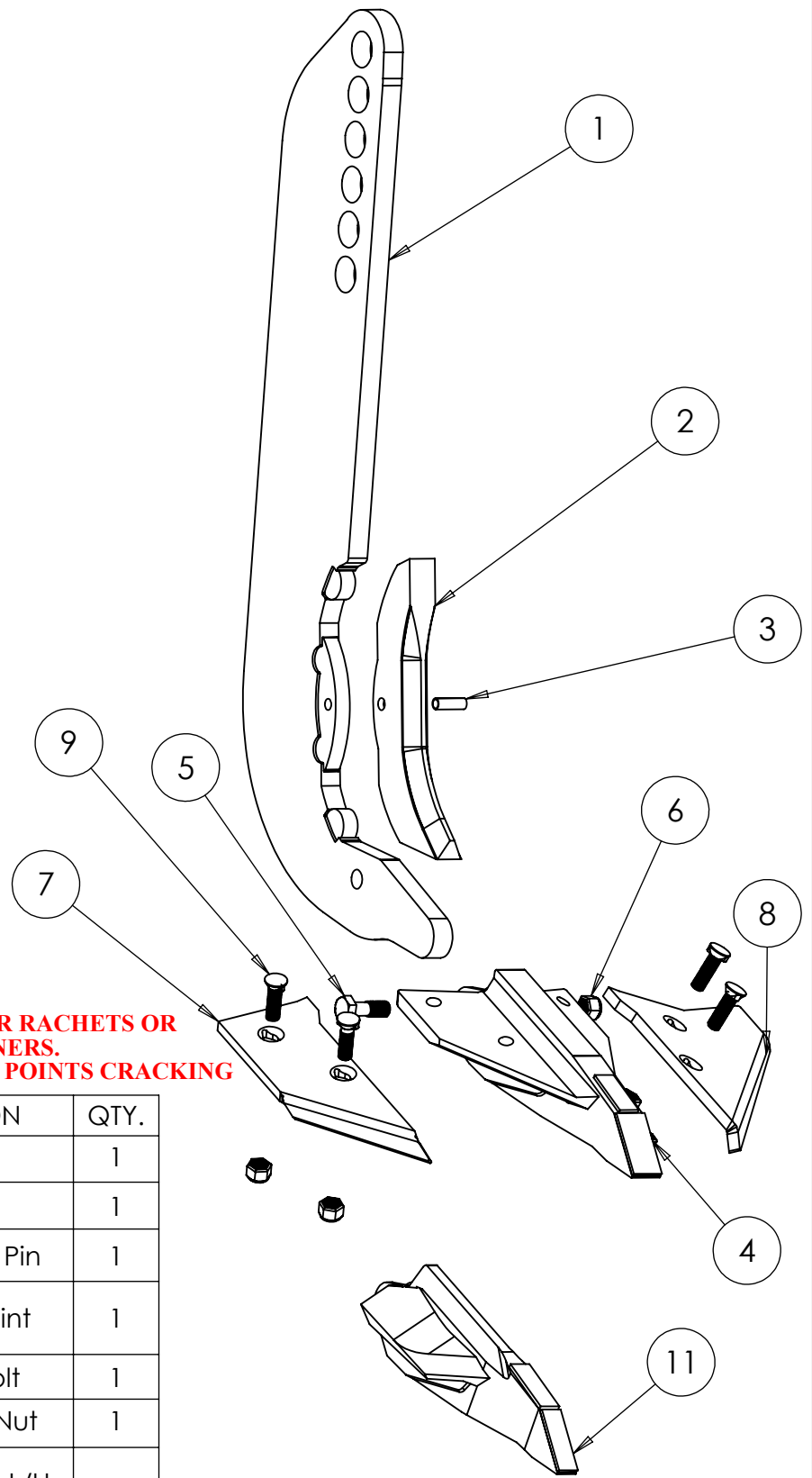
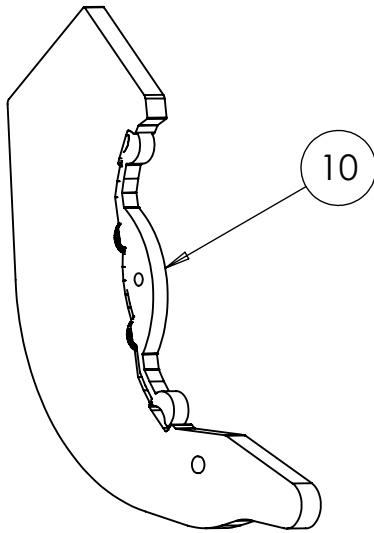

DO NOT TIGHTEN POINTS UP WITH AIR RACHETS OR OVER TIGHTEN WITH SPANNERS. EXCESSIVE TIGHTENING WILL RESULT IN POINTS CRACKING

ITEM NO.	PART NO.	DESCRIPTION	QTY.
1	SW1046	Leg	1
2	SW1048	Cast Shin	1
3	SWB183	M10 x 30 Roll Pin	1
4	SW1050	Concord Point	1
5	SWM1250	M12 x 50 Bolt	1
6	SWM12004	M12 Nylock Nut	1
7	SWB401/400	4" R/H Wing & L/H Wing (Not Shown)	2
8	SWB366/367	8" L/H Wing & R/H Wing (Not Shown)	2
9	SWM1235TN	M12 x 35 Twin Nibbed Bolt c/w Plain Nut	4
10	SW1047	Weld on Leg Bottom	1
11	SWB441	Low Disturbance Point	1

DO NOT SCALE DRAWING

MACHINE/COMPONENT:

LDS

TITLE:

Arable Leg Assembly



Drawings and design information found herein remain the sole property of Sumo UK Ltd. Reproductions may only be made with the permission of the owner.

SCALE 1:6

REVISION:

DATE: 24/04/14

INITIAL: TW

6.9 Light Assembly

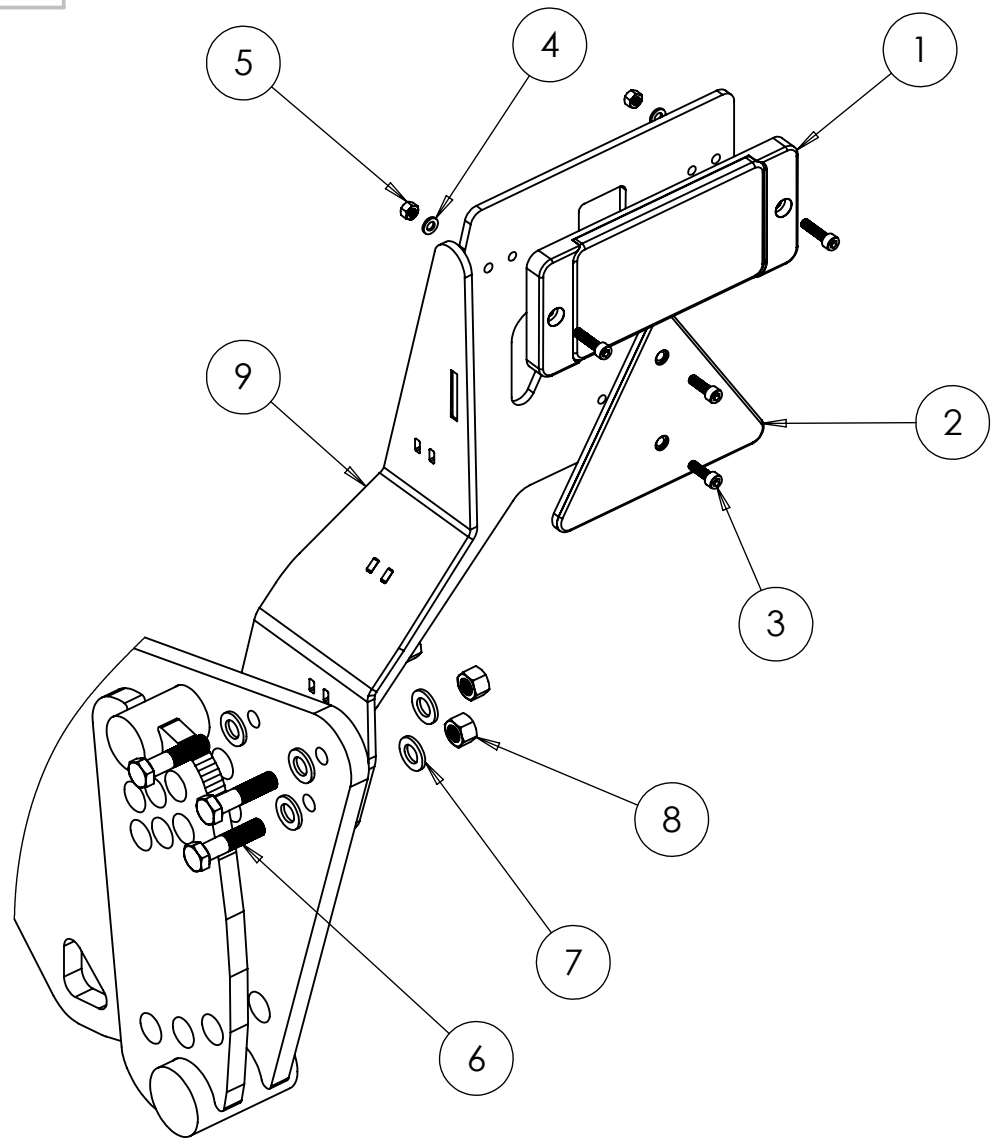

ITEM NO.	PART NO.	DESCRIPTION	QTY.
1	SWB715	Rear Light	1
2	SWB162	Warning Triangle	1
3	SWM616CSK	M6 x 16 Countersunk Bolt	4
4	SWM6001	M6 Washer	8
5	SWM6004	M6 Nut	8
6	SWM1650	M16 x 50 Bolt	3
7	SWM16001	M16 Washer	6
8	SWM16004	M16 nylock Nut	3
9	SW1554/SW1555	LDS Light Bracket L/H & R/H (not shown)	1
10	SWB175	Wiring Loom (not shown)	1

DO NOT SCALE DRAWING

MACHINE/COMPONENT:

LDS

TITLE:

Light Assembly



Drawings and design information found herein remain the sole property of Sumo UK Ltd. Reproductions may only be made with the permission of the owner.

SCALE 1:3

REVISION:

DATE: 24/04/14

INITIAL: TW

6.10 Main Frame Headstock

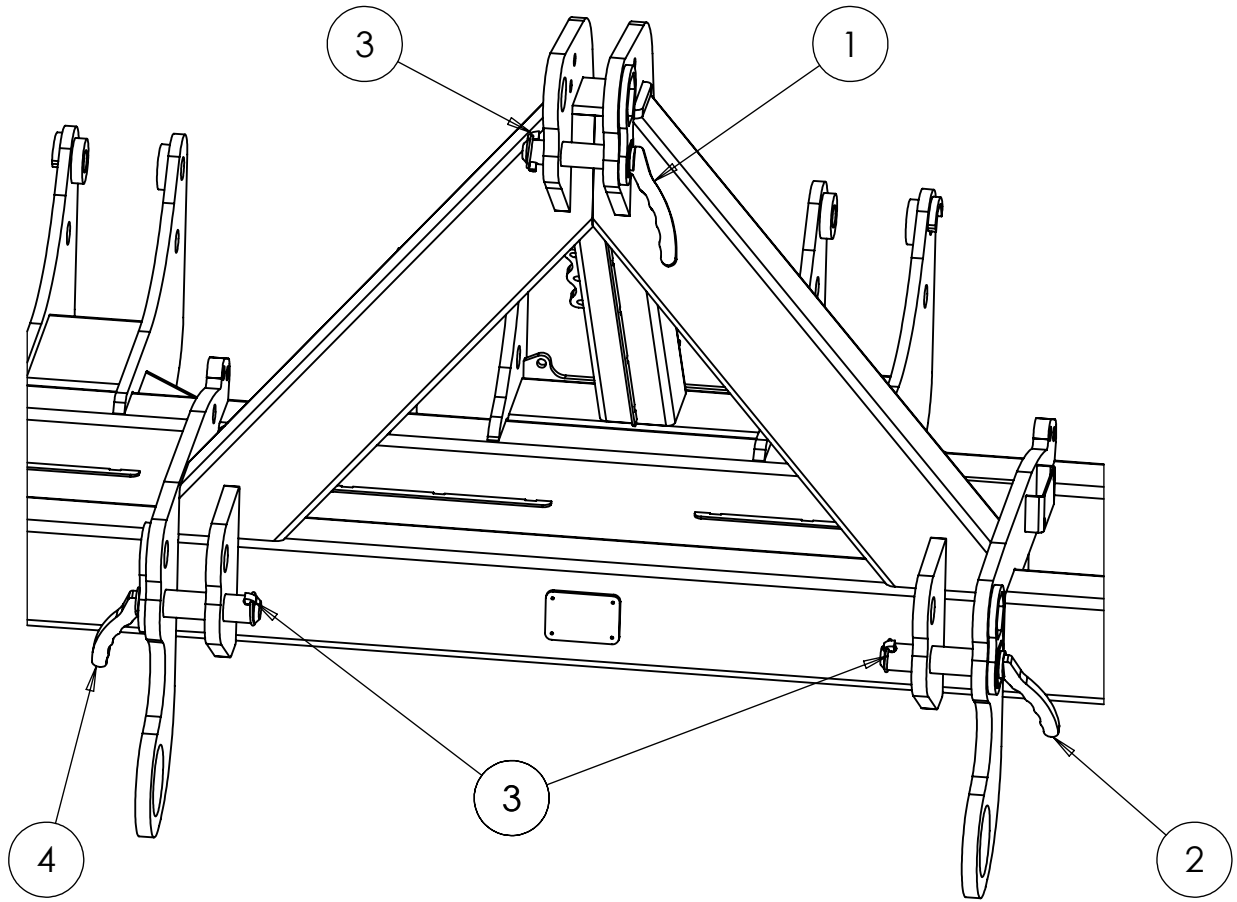

ITEM NO.	PART NO.	DESCRIPTION	QTY.
1	SW627	Cat III Top Link Pin	1
2	SW626	Cat III Lower Link Pin	2
3	SWB107	Cat II Safety Lynch Pin	3
4	SW1141	Lower Link Pin Spacer (not shown)	2
5	SW1142	Top Link Pin Spacer (not shown)	1

DO NOT SCALE DRAWING	
MACHINE/COMPONENT: LDS	
TITLE: Main Frame Headstock	
	
<small>Drawings and design information found herein remain the sole property of Sumo UK Ltd. Reproductions may only be made with the permission of the owner.</small>	
SCALE 1:10	REVISION:
DATE: 24/04/14	INITIAL: TW

6.11 Folding

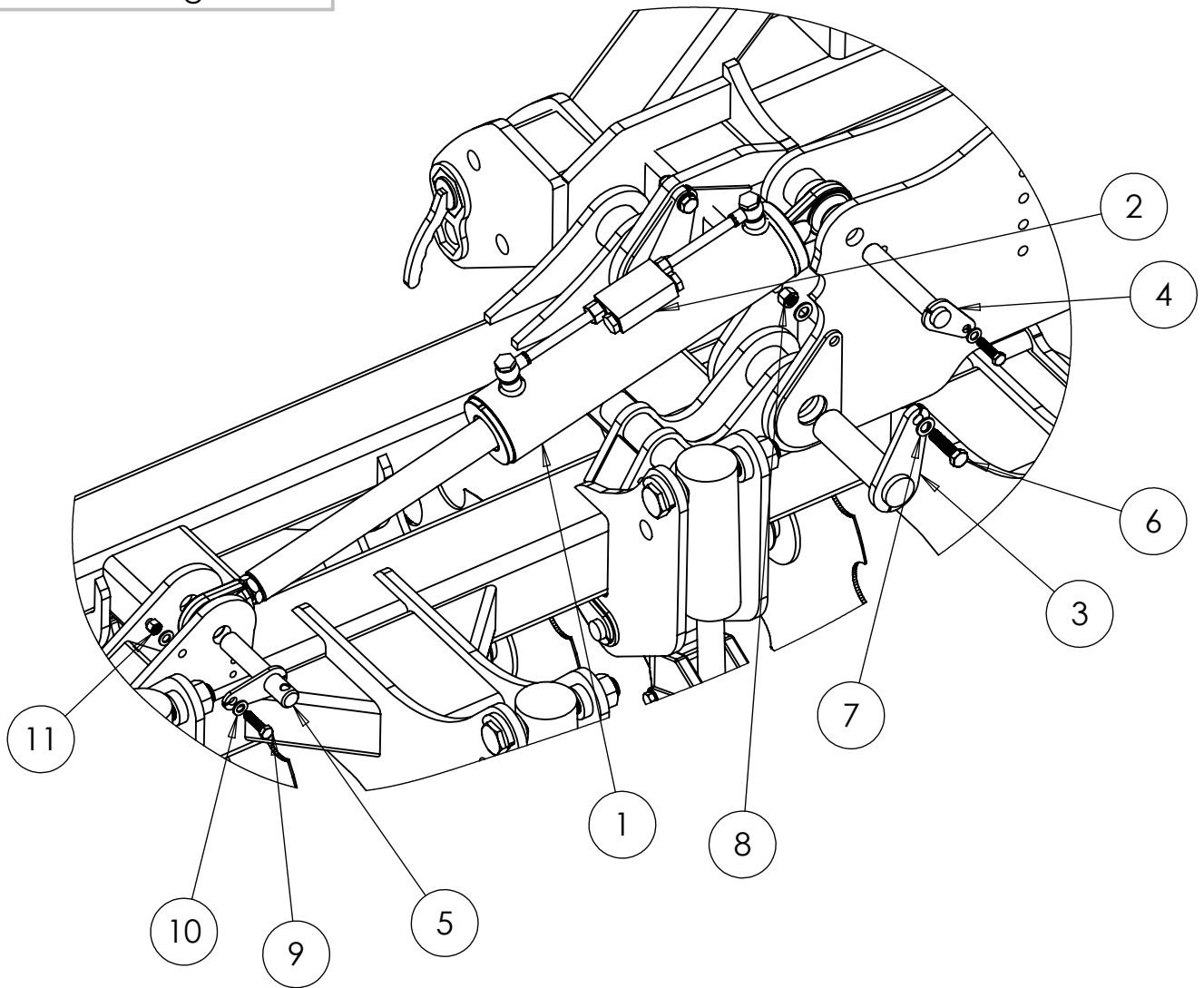

ITEM NO.	PART NO.	DESCRIPTION	QTY
1	SWH361	706/4 ball ended Ram	2
2	SWH154	Check Valve	2
3	SWP50x170	Hinge Pivot Pin	4
4	SWP30x170	Top Ram Pin	2
5	SWP30x110DB	Bottom Ram Dog Bone Pin	2
6	SWM1660	M16 x 60 Bolt	4
7	SWM16001	M16 Flat Washer	8
8	SWM16004	M16 Nut	4
9	SWM1245	M12 x 45 Bolt	4
10	SWM12001	M12 Flat Washer	8
11	SWM12004	M12 Nut	4
12	SW1998	Anti Fold Bar (not shown)	2
13	SW2106	Anti Fold Bar Holder (not shown)	1

DO NOT SCALE DRAWING

PRE

MACHINE/COMPONENT:

LDS

TITLE:

Folding Assembly



Drawings and design information found herein remain the sole property of Sumo UK Ltd. Reproductions may only be made with the permission of the owner.









SCALE:1:10

REVISION:

DATE: 08/12/14

INITIAL: TW

6.12 Stickers and Paint

Sticker	Description	Quantity	Part No.
	Big Sumo horizontal sticker 450 x 125mm	2	SWB125
	Big Union Jack sticker 150 x 100mm	2	SWB127
	Vertical Sumo sticker 80 x 295mm	2	SWB128
	Small Union Jack sticker	2	SWB129
	Small Sumo Reflective Sticker	2	SWB199
	Small Sumo Horizontal Sticker	4	SWB130
	Small LDS 3 Sticker	2	SWB677
	Large LDS 3 Sticker	2	SWB678
Sumo touch up paint	Sumo Red	1/2 Litre	SWB131
	Sumo Black	1/2 Litre	SWB132