

# **SUMO**

sumo1.com

# **STRAKE**

## **2016 Operator Manual and Parts List**

### **12m Strake**



**Read this manual carefully prior to operating the machine  
and store with the machine.**

SUMO Serial No. :



Redgates  
Melbourne  
York  
YO424RG  
Tel: 01759 319900  
Fax: 01759 319901  
[www.sumo1.com](http://www.sumo1.com)

## **EC DECLARATION OF CONFORMITY (RL 2006/42/EC)**

**MANUFACTURER:** Sumo UK Ltd

**ADDRESS:** Redgates, Melbourne, York, YO42 4RG.

**COUNTRY:** United Kingdom

**PRODUCT DESCRIPTION:** Sumo STRAKE

**MODEL:** 12m

**DATE:** March 2015

This product conforms to all the essential health and safety requirements of the EC Directive 2006/42/EC



This document is approved by:

**NAME:** Mr. Shaun Wealleans

**POSITION:** Technical Director

**SIGNATURE:**

**PLACE:** Sumo UK Ltd, Redgates, Melbourne, York, YO42 4RG, United Kingdom.

**DATE:** March 2015





**In order to obtain your free pair of Sumo overalls and baseball cap** please fill in this form and send back to us at:

Sumo UK Ltd  
Redgates  
Melbourne  
York  
YO42 4RG  
Tel: 01759 319900  
Fax: 01759319901

<b>Overall Size</b>	Tick where applicable.
Small (38 chest)	
Medium (42 chest)	
Large (46 chest)	
Extra-large (50 chest)	
XX Large (54 chest)	
XXX Large (58 chest)	

<b>Position</b>	
Farm Owner	
Farm Manager	
Farm Worker	

<b>Farm type</b>	
Arable	
Vegetable	
Livestock	
Mixed	

<b>Farm Size</b>	
0-250ac	
251-500ac	
501-1000ac	
1000+ac	



## Contents

1.0 Introduction .....	2	8.2 Adjustments – tine aggression.....	14
2.0 Warnings .....	2	8.3 Adjustments – tine spacing.....	15
3.0 Service .....	2	8.4 Adjustments - forward speed .....	16
3.1 Warranty claims .....	2	8.5 Adjustments – wing pressure .....	16
4.0 Safety and Responsibility .....	3	9.0 Maintenance .....	17
4.1 Intended use .....	3	9.1 Maintenance - points.....	17
4.2 Spares.....	3	9.2 Maintenance - greasing .....	17
4.3 Qualification of operators.....	3	9.3 Maintenance - storage.....	17
4.4 Machine operators.....	4	10.0 Hydraulic Systems.....	18
4.5 Sumo trained operators.....	4	10.1 Circuit diagram; Tine Adjust function (Row nos.1, 3 & 5).....	18
4.6 Children.....	4	10.2 Circuit diagram; Height Adjust function .....	18
4.7 Personal Protective Equipment (PPE) ...	4	10.3 Circuit diagram; Main Lift & Fold .....	19
4.8 Road transportation.....	4	10.4 Circuit diagram; Tine Adjust function (Row nos.2, 4 & 6).....	19
4.9 Operation Safety .....	5	10.5 Circuit diagram; Wing Fold .....	20
4.10 General Safety.....	5	11.0 Parts .....	21
5.0 Commissioning & Care .....	5	11.1 Lighting Assembly .....	22
5.1 Avoiding damage to the machine .....	6	11.2 Tine pivot assembly .....	23
5.2 Retrofitting.....	6	11.3 Push rod assembly .....	24
5.3 Hitching and Unhitching.....	6	11.4 Tine assembly .....	25
5.4 Hydraulic System.....	7	11.5 Tine bar overview .....	26
5.5 Pressure Accumulator .....	7	11.6 Headstock and parallel arms .....	27
5.6 Brake System.....	7	11.7 Wing and headstock overview.....	28
5.7 Overhead power lines.....	7	11.8 Depth wheel assembly.....	29
5.8 Environmental Protection.....	7	11.9 Decals.....	30
5.9 Danger Zone .....	8		
6.0 Safety Stickers .....	9		
7.0 Operation .....	10		
7.1 Operation - Overview.....	10		
7.2 Operation - Turning.....	10		
7.3 Operation – folding .....	11		
7.4 Operation – Hydraulics .....	13		
8.0 Adjustments .....	14		
8.1 Adjustments – wing height .....	14		



## 1.0 Introduction

Prior to operating the machine, these instructions must be read and complied with. This will reduce the chance of injury, reduce the chance of machine misuse which could result in failure of parts and significantly reduce the service life of the machine.

Sumo will not accept liability for any injuries or damage caused from failing to comply with the instructions within this manual.

The instructions within this manual will enable the operator to operate the machine in a safe manner and reduce risk to themselves and persons around the machine while it is in operation.

As well as reading the instructions of operation contained within this manual, a trained technician or dealer should also instruct you on the correct and safe use of the machine and maintenance of the machine to ensure a long service life.

By signing the document contained at the front of this manual you are accepting the receipt of this manual. The warranty starts on the day of delivery of the machine.

The illustrations within this manual may be subject to change and may differ from the machine you have received.

## 2.0 Warnings

Within these instructions are warnings of safety to protect the health of the user and the persons surrounding the machine during its operation.

Please read and ensure that these warnings are complied with.

The designations "left", "right", "front" and "rear" refer to the direction of travel, as seen in the direction of travel, as the operator is sat in the driving seat looking forward.

## 3.0 Service

Sumo endeavour to ensure that the machine leaves the factory in perfect working order, if this is not the case then please let us know as soon as possible.

If you encounter any issues with your machine please contact us or your Sumo dealer, and we will work to resolve the issue as quickly as possible.

To allow us to process the problem quickly we will need the following information:

- Customer name and address
- Sumo dealer name
- Machine model
- Serial number
- Area covered by machine
- Type of problem

### 3.1 Warranty claims

Any warranty claims must be submitted through your local Sumo dealer.

If damage to the machine has been caused by external influences then the warranty claim cannot be honoured. Influences such as:

- Excessive wear of wearing parts
- Missing wearing parts
- Excessive operating speeds
- Excessive transport speeds

- Incorrect set up of machine (hydraulic connections, non-even depth adjustment)
- Failing to comply with safety and operating instructions
- Neglect of maintenance of the machine.

## 4.0 Safety and Responsibility

The following warnings and safety instructions apply to all sections of these operating instructions.

The machine has been designed and manufactured to meet all of the relevant safety regulations. These regulations along with the instructions provided within this manual will ensure that risk of injury to yourself or others is minimised.

Please read **ALL** of these safety instructions prior to the first use of the machine to prevent safety issues or potential machine damage to the machine through incorrect use.

### 4.1 Intended use

Any use outside of the intended use of the machine can lead to injury or persons operating or within the area of the machine during operation and can also lead to invalidating the warranty. The machine is intended to be used for normal soil cultivation in agricultural practices.

Any faults with the machine should be rectified prior to use of the machine. Faults can cause safety issues and can also cause the machine to work in an unsatisfactory manner.

Only qualified persons may operate this machine, they must be familiar with the

machine and familiar with the dangers of the machine.

### 4.2 Spares

The machine has been designed to take Sumo manufactured spares; non-genuine parts may damage the machine as they are untested and not recommended for use with the Sumo machine. Sumo will not honour warranty claims if deemed to be caused by the use of non-genuine parts or accessories.

Safety stickers should always be replaced along with the components they are attached to; this will ensure the safety of the machine is not compromised.

### 4.3 Qualification of operators

Use of the machine by untrained operators can lead to injury or even death. To prevent accidents occurring ensure that operators have been trained by a Sumo dealer or technician. The following requirements must be met:

- Personnel must be of statutory minimum age in the country of operation.
- Ensure only authorised persons operate or work on the maintenance of the machine.
- The person has read and understood these instructions in full.
- The person is fully competent in operating the machine towing the equipment.
- Local traffic laws are abided by
- A person being instructed on the use of the machine must be done so under the instruction of a trained individual.

The owner of the machine must ensure that these requirements are met and the area of responsibility is met, train any per-

sons intending on using the machine to ensure they are up to the required standards and ensure that they have read and understood this manual.

#### **4.4 Machine operators**

These persons have been trained by the owner or dealer to use and set up the machine in the field, transport the machine on the road, maintain the machine and troubleshoot errors with the machine.

#### **4.5 Sumo trained operators**

Higher training by Sumo is required for the following operations; loading for truck transportation, commissioning of new machines, advanced troubleshooting and repair.

Any repair work to structural components of the machine must be carried out by Sumo or a workshop approved by Sumo, otherwise the warranty will be compromised.

#### **4.6 Children**

Young persons are less able to react to danger and are unlikely to have enough experience to react to situations so as such should be kept clear of the operating zone of the machine. Children should NOT be left in the tractor even when the machine has been shut down as hydraulics can still be operated if they are a mechanical spool. The minimum age of children riding on agricultural equipment locally in the country of operation must be adhered to.

#### **4.7 Personal Protective Equipment (PPE)**

To protect the user and persons surrounding the machine during operation suitable PPE must be worn.

Tight fitting clothes or overalls should be worn to ensure no loose clothing is able to get caught in the machine while it is in operation, this includes long hair, which should be tied up or placed in a hair net.

Suitable footwear should be worn, steel toe capped shoes/boots should be worn to protect when components are being lowered to the floor.

Eye protection such as safety glasses or goggles must be worn during the changing of wearing components as these may be under pressure and can release suddenly, and when working with hydraulic components as the pressure may not have been released properly and could release suddenly.

Jewellery such as rings, bracelets and watches should not be worn while operating this machine as it has the ability to get caught and cause further injury to the operator.

Hand protection should be worn during the attachment of the machine to a tractor as hydraulic oil can cause injury if it is under pressure as it can pierce the skin and can cause serious health problems if it enters the blood stream.

#### **4.8 Road transportation**

When the machine is being transported on the road the local road regulations must be adhered to, regulations such as transport width and height. The route



planned should also be considered to ensure that the machine will fit under low bridges and between narrow gaps.

The way in which the Sumo Strake is configured means the transportation wheels are at the very rear of the machine, meaning that it cuts corners, ensure that a wide swing is taken to tackle corners to prevent damage being caused to the machine or the machine fouling other vehicles on the highway.

When transporting the machine on the highway it must be folded into the correct transportation position.

#### **4.9 Operation Safety**

This manual contains basic advice, which should be observed during setting-up, operation and maintenance. Therefore, this operating manual must be read by the personnel concerned prior to starting up and using the machine and be accessible at all times.

If safety instructions are not complied with, then this can lead to the risk of injury to yourself and others as well as damage to the environment or the machine. Non-compliance to the safety instructions can also lead to any warranty claims becoming invalid.

#### **4.10 General Safety**

To avoid serious injury please ensure that the tractor keys are removed before making any adjustments and maintenance.

Warning signs and other notices on the machine provide important information for the safe operation. Observing them

will serve your safety. Before commencing work, make yourself familiar with all the equipment and controls as well as their functions. Keep the machine and in particular; any bearings clean to avoid risk of fire.

Check around the machine before moving off or starting up (watch out for children!). Make sure you have adequate all-round visibility. Always match your speed to the local conditions. Avoid sudden turning manoeuvres when driving uphill or downhill or when travelling across a slope. Observe the respective regulations when using public roads. Take into account the length, the wide overhang, the folded height and the sideways force acting on the machine when turning or negotiating corners.

### **5.0 Commissioning & Care**

Before operation of the Sumo Strake, a full commissioning should take place to avoid the potential for severe or even fatal accidents. Whilst the Sumo Strake undergoes a thorough inspection before leaving the factory, it cannot be guaranteed that it is safe to use for immediate operation. This could be due to a number of factors including tampering or the transport environment it has been delivered in. It is imperative that full instruction should be undertaken by an authorised SUMO dealer or by an appropriate SUMO UK technician, on initial operation. It is policy that a machine should be registered for use by the end user on delivery of the machine by Sumo UK or any authorised SUMO dealer. Any

initial operation prior to an official commissioning of the machine that leads to damage of the machinery, or the serious/fatal injury to personnel/third party claimants will not be the responsibility of SUMO UK. It is highly recommended that prior to initial/daily use that nuts and bolts be checked and tightened appropriately on vital components to avoid unnecessary damage and or injury.

### **5.1 Avoiding damage to the machine**

Avoiding unnecessary damage can both prolong the life of the machine and ensure that the machine can be operated safely throughout its life. Damage to the machine can result in serious or fatal injury to operators and third parties. Care should be taken in identifying damaged parts and appropriately replacing the damaged items with Sumo genuine parts. Unnecessary damage can be avoided if the machine is regularly serviced and maintained within SUMO guidelines. Items that should be inspected daily as a good safety practice are:

- Hydraulic System
- Brakes
- Hitch System
- Lighting
- Wheels and tyres
- Any safety Mechanisms

If a particular component is showing signs of damage that poses a risk to operator and/or third party safety, operation must either not commence or cease until the fault is assessed and rectified by a competent/qualified person(s).

### **5.2 Retrofitting**

Structural changes and extensions can adversely affect the functionality and the operational safety of the machine. This can lead to severe or even fatal physical injuries.

- Do not make any structural changes or extensions which have not been approved by SUMO UK.
- Structural changes and extensions must only be made in an authorised workshop or by an operator who has been instructed by SUMO UK.
- Comply with country specific instructions for weights, weight distribution and dimensions.

For retrofits influencing the weight or weight distribution one must check and comply with the regulations concerning towing facilities, support and axle loads.

### **5.3 Hitching and Unhitching**

Faulty hitching up of the machine to the tractor causes dangers, which could result in severe accidents. Hitching and unhitching of the machine should only take place on a secure and level surface with chocks placed under the machine transport wheels to prevent machine rolling away.

Never allow persons to stand between the tractor and the SUMO machine whilst the tractor is manoeuvring into position. Once the tractor is in position and secured against rolling away by means of parking brake and/or wheel chocks, can the operator/third party secure the machine to the tractor.

Ensure the wings are either fully up and folded in the “transport” position or fully

down in the “work” position before uncoupling from the tractor. The machine should always remain secured to the tractor when the wings are anywhere between fully up and fully down.

#### **5.4 Hydraulic System**

The hydraulic system is under high pressure. Hydraulic oil escaping under pressure can penetrate the skin and cause serious injuries. In the event of injury, consult a doctor immediately.

The machine's hydraulic system has several functions, which can cause injury to persons or damage to the machine, if operated incorrectly.

- Do not connect hydraulic hoses to the tractor, before both hydraulic systems on machine and tractor are de-pressurised.
- The hydraulic system is under high pressure. Check all lines, hoses and screwed connections regularly for leaks and any visible external damage!
- Use only appropriate means when searching for leaks. Repair any damage immediately! Oil sprays can cause injuries and fire!
- Power sockets and connectors on the hydraulic connections should be marked in order to exclude operating errors.
- In the case of injury, contact a doctor immediately!

#### **5.5 Pressure Accumulator**

The hydraulic system uses high pressure accumulators, which can present a danger if tampered with or misused. This includes drilling, welding or any other process that could compromise the safety of the accumulator. It is recommended that the

operator or any third party does NOT try to dismantle or adjust the accumulator in any way. If the accumulator fails it should be changed under the instruction of SUMO UK.

#### **5.6 Brake System**

Brake systems are usually one of two formats, either pneumatic or hydraulically operated. Each system should be checked daily before use to determine if the braking is fully functional. Any adjustments or modifications to the braking system should be carried out by or under the instruction of SUMO UK.

#### **5.7 Overhead power lines**

Special care should be taken when folding and un-folding a machine in the proximity of overhead power lines. To prevent severe injury or damage to the machine always keep a safe distance from pylons and powerlines when unfolding. When the machine is being operated it is important to manoeuvre around pylons and overhead power lines carefully to avoid damage to pylons that may even cause a pylon collapse resulting in severe or fatal injury and/or machine electrical damage. A machine should also never be parked or accessed beneath powerlines as this could cause a voltage flashover leading to severe/fatal electric shock or even fire.

#### **5.8 Environmental Protection**

Operating fluids such as hydraulic oil and lubricants are damaging to the environment. Special care should be taken to ensure that operating fluids are not leaking to ensure safe operation of the machine and damage to the environment. When servicing of the machine it is

important that the disposal of used operating fluids is done responsibly.

### 5.9 Danger Zone

The area marked red indicates the danger zone of the machine.

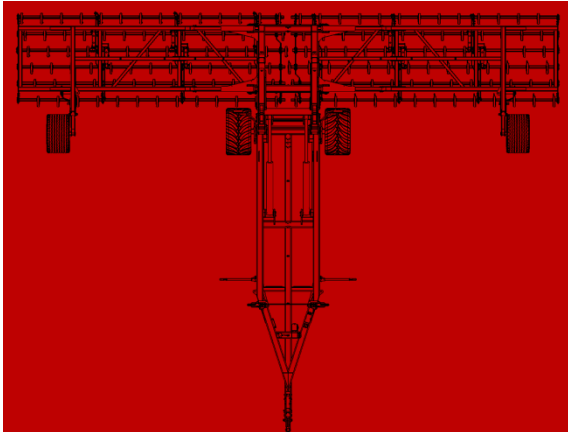

The danger zone around the machine poses the following endangerments:

- Accidental operation of the hydraulic system can trigger dangerous movements of the machine.
- Defective or not correctly fastened electric lines can cause electric shocks.

- With the drive still running, machine parts may rotate or swing out.
- Hydraulically raised machine parts can lower slowly and unnoticed.

Failing to pay attention to the danger zone can result in severe or even fatal physical injuries.

- Do not stand under lifted loads. Lower such loads to the ground first.
- Instruct persons to leave the danger zone around the machine and tractor.
- Before working in the danger zone of the machine or between machine and tractor: **Shut down the tractor!** This also applies for short-term inspection work. **Many accidents happen because of carelessness and running machines!**
- Pay attention to the information in all operating instructions.

## 6.0 Safety Stickers

Safety stickers on the machine warn of dangerous points and are an important part of the safety equipment of the machine. Missing safety stickers increase the risk of severe or even fatal physical injuries.

	<p>Risk of falling.</p> <p>No persons to ride on the machine.</p>
	<p>Risk of crush injuries.</p> <p>Stay clear of unfolding and/or swinging elements of the machine.</p>
	<p>Stay clear of machine while manoeuvring and working.</p>
	<p>CAUTION.</p> <p>Read manual carefully before operation</p>
	<p>Never reach in to working parts.</p> <p>Risk of crush injury.</p>

## 7.0 Operation

### 7.1 Operation - Overview

The SUMO Strake is a versatile machine which offers a multitude of benefits. The even distribution of chaff and straw combined with mixing with soil is essential when encouraging the growth of unwanted seeds including blackgrass.

The 15mm carbide tips, combined with powerful spring tines prove an ideal combination when wanting to achieve a shallow tilth. This disturbance will provide the ideal conditions for the rogue seeds to chit.

The superior frame build quality and tine design allows forward speeds of 10 – 25kph giving unrivalled performance even in the hardest ground

The Sumo Strake prepares the stubble for the next pass which makes drilling, cultivating or ploughing easier due to even trash distribution.

### 7.2 Operation - Turning

Turning in work; there are several options depending on the method of working.

- Firstly, the wings can be jacked out of work via retracting the two main lift rams, this allows for the tine aggression angle to be exactly maintained.
- The second option is to leave the wings in their work position and simply rotate the tines out of work.
- The third and final method being to leave the wings and tine in “work” and take wide turns leaving large headlands, missing a bout is good practice. Turning too tightly while using this method can result in breakages both to the tines and the framework due to the extremity of the inside wing moving backwards forcing the tines against their natural spring action. In simple terms, ensure all areas of the wings are moving forward at all times while in work.

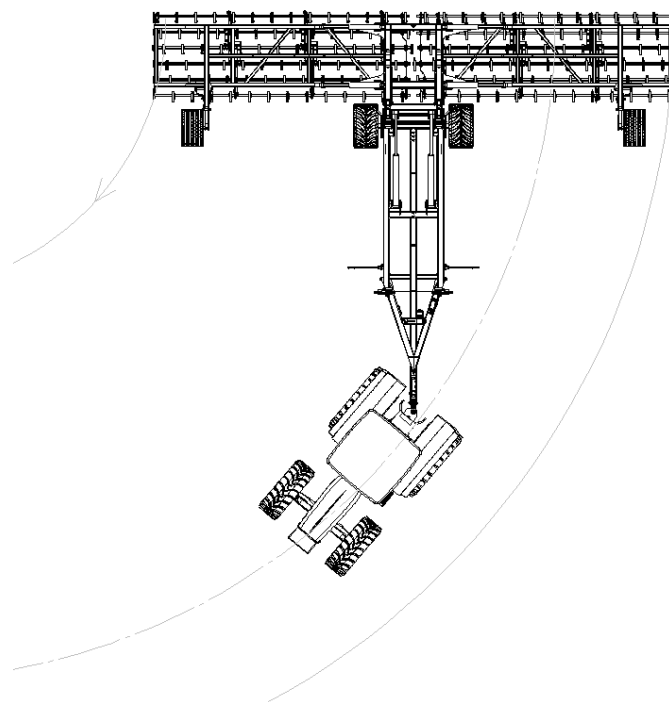

### 7.3 Operation – folding

When transporting the Strake it is absolutely imperative that the wings are folded and sat in their carrying cradles. Firstly the tines should be rotated to their upper most horizontal position.

To achieve the folding state, certain conditions must be applied; depth pins must be altered on both the headstock and the depth wheels in order to reposition the wings to the settings depicted below. Once the headstock pin is relocated, the parallel lift rams should be retracted down

Once this state is achieved, the main lift rams can then be retracted to a point where the wings are almost perpendicular to the ground. Next, the wing fold rams can be retracted to fold the wings inward. The rollers on the wing depth wheel mounts will contact against the rest back stop, at which point the main lift rams can be retracted their final amount to lower the roller into the carrying cradles.

1. Rotate both sets of tines up

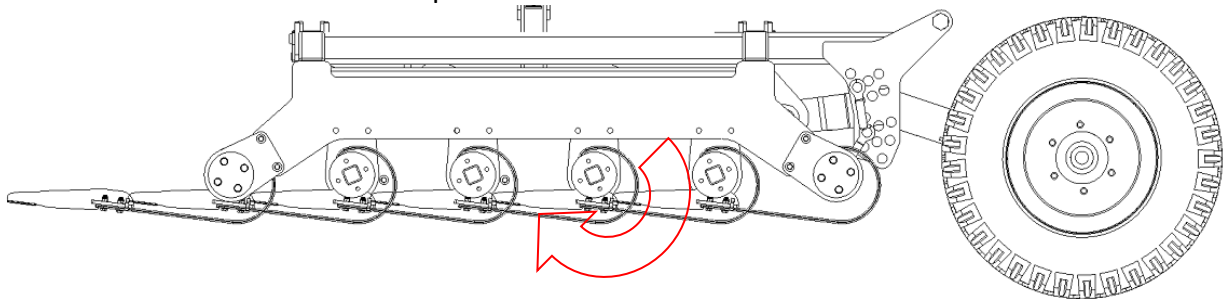

2. Set working height pins as per these images

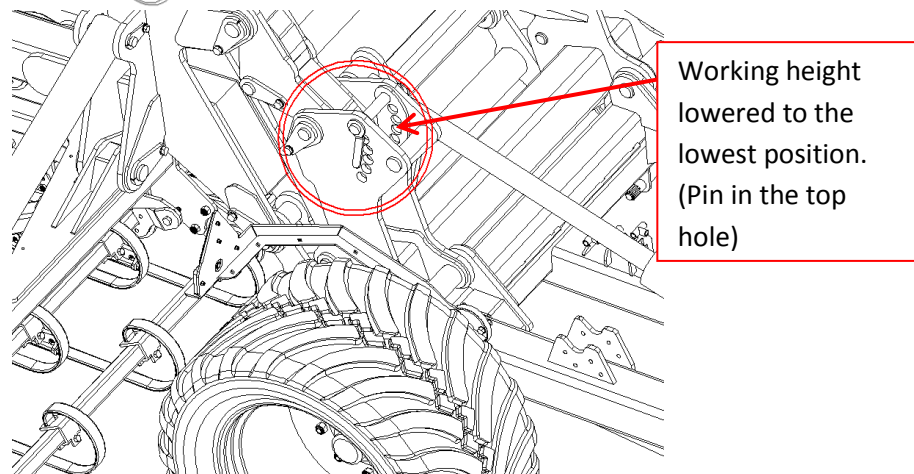
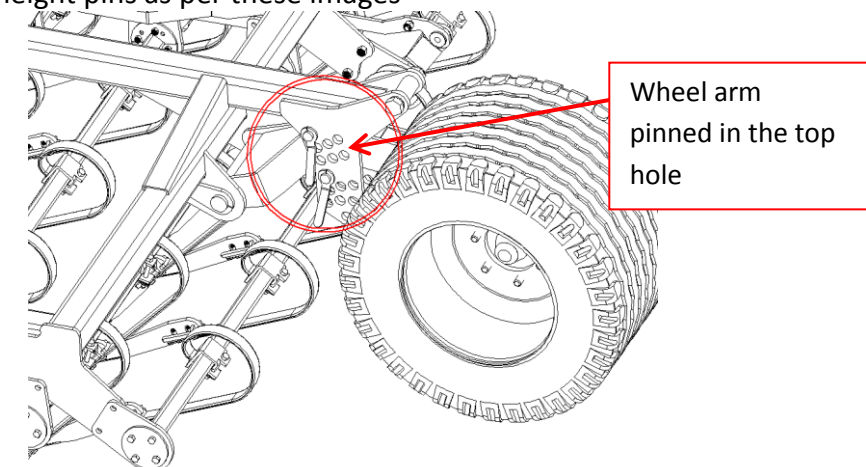

3. Fold headstock & wings up to almost (but not quite) vertical

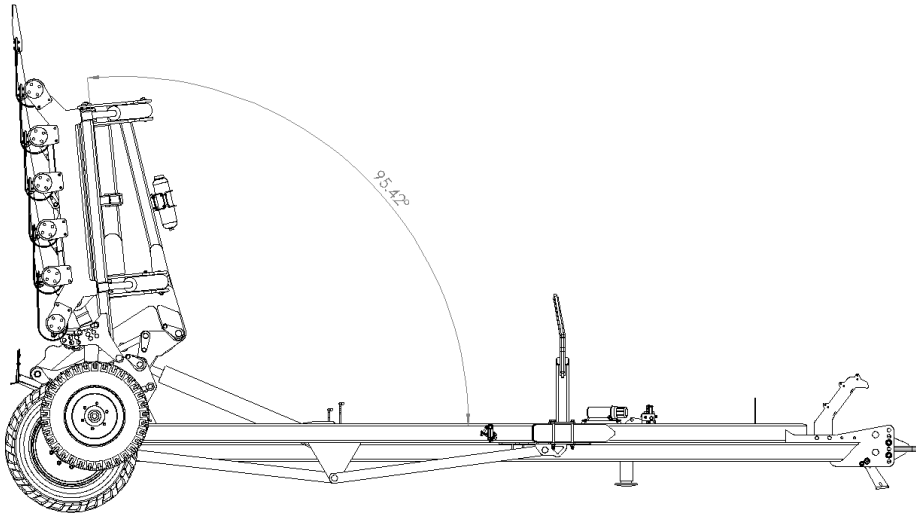

4. Fold wings in to the point at which the wing rollers contact the cradle backstop

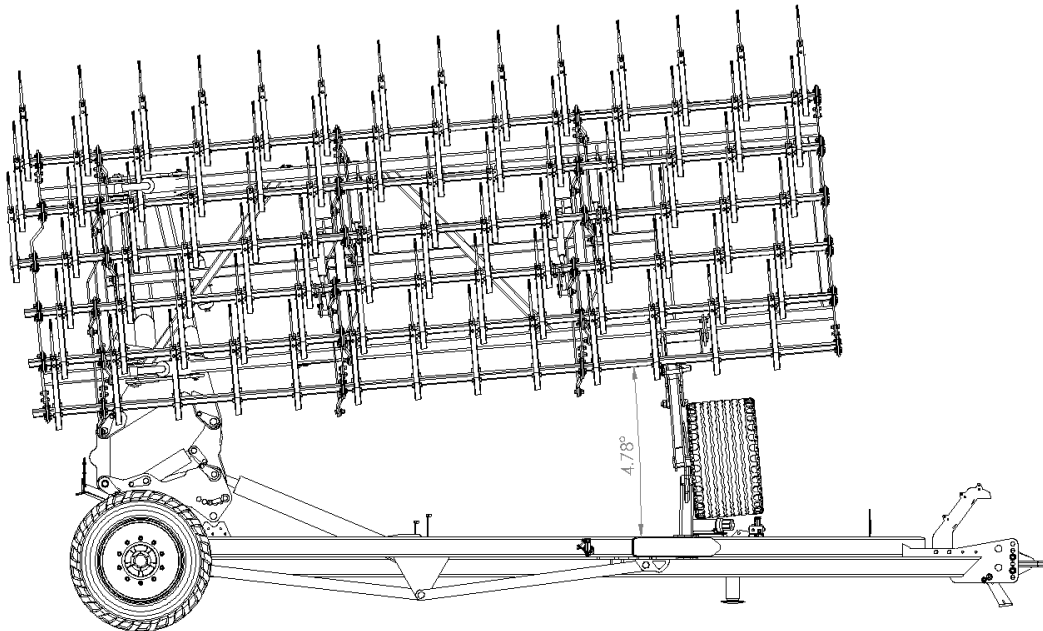

5. Gently lower the wings down into the carrying cradles

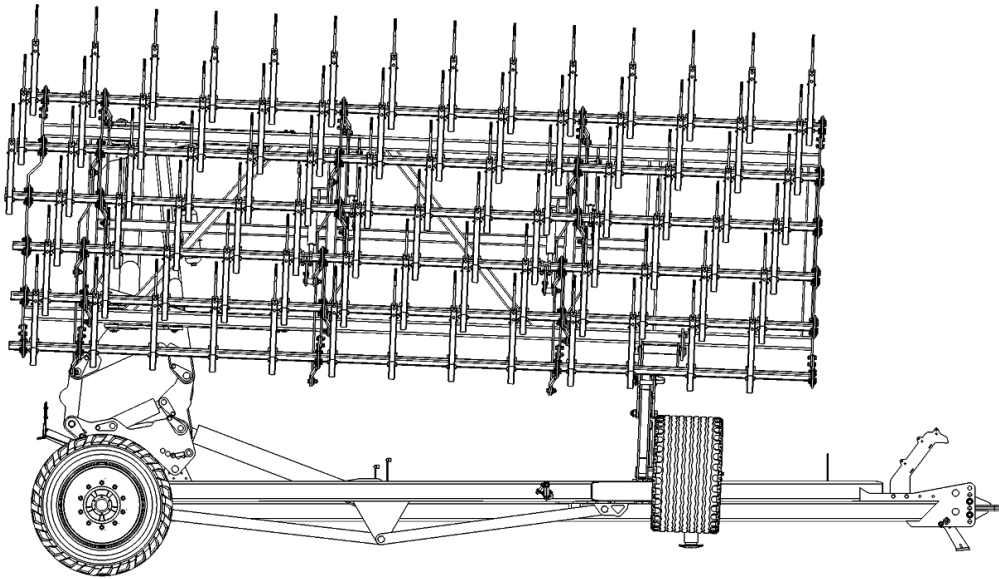

6. Perform this procedure in reverse to unfold.

#### 7.4 Operation – Hydraulics

The Strake has five hydraulic functions and due to the fact that most tractors are equipped with only four spool valves, a manual change-over valve is provided for convenience. The consequence of this being that one function (wing fold) is sacrificed during normal work but it does mean only four pairs of hoses (plus the brake line) are presented to the tractor. The five functions are detailed below.

- Main lift
- Odd tine rows - 1, 3, & 5
- Even tine rows 2, 6 & 6 ...
- Wing fold .....
- Parallel height up/down

These two are on the manual change-over valve, with the “Even tine rows” intended to be active when in normal use.

## 8.0 Adjustments

### 8.1 Adjustments – wing height

The Strake has the ability to perform in a high clearance state with the wings raised allowing more scope for tine position and conversely, the wings can be lowered for a more gentle raking action. The lower position is more suited to high trash conditions due to the spring tines being in a more relaxed position which enables straw and general harvest debris to flow through.

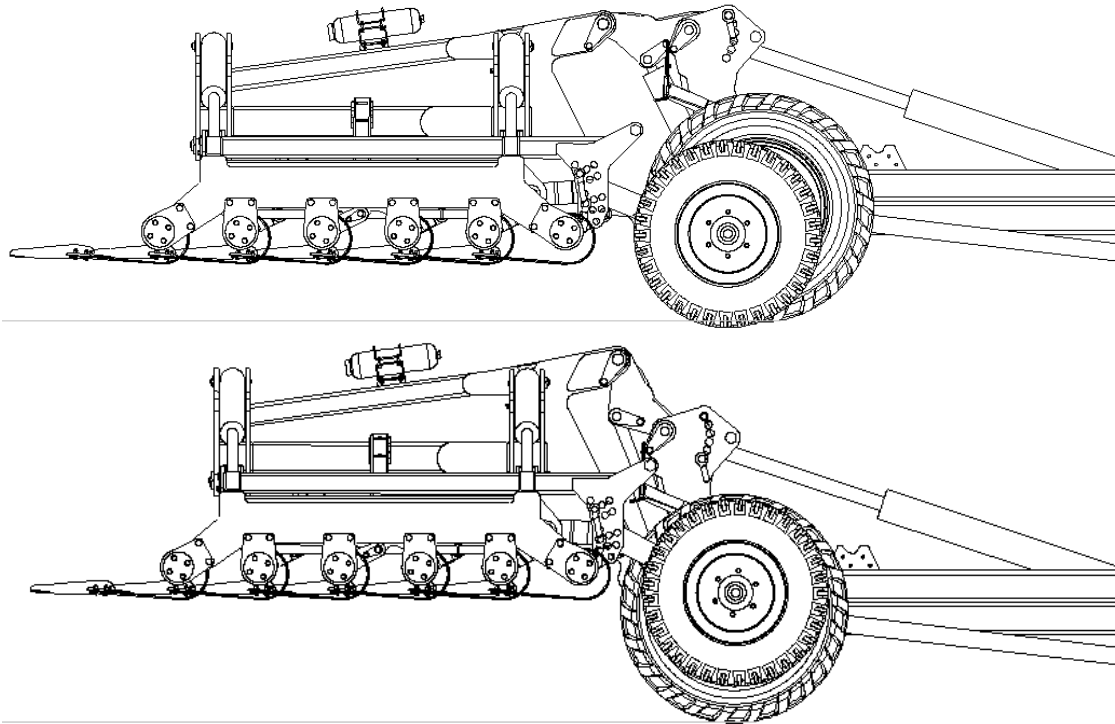

These images depict the wing height range. The depth wheel pin position on the wing should be set to correspond with that of the headstock, sometimes it is necessary to vary these positions dependant upon tyre deflection, ground conditions and field undulations.

### 8.2 Adjustments – tine aggression

In addition to the wing height, the aggression of the tines can be altered too. With the tines nearer to vertical, the aggression of the tines is at the highest with more penetration achievable. Rotating the tines closer to the horizontal provides less aggression but improved trash handling in terms of the tines being less prone to holding on to straw.

Tine aggression operating range.

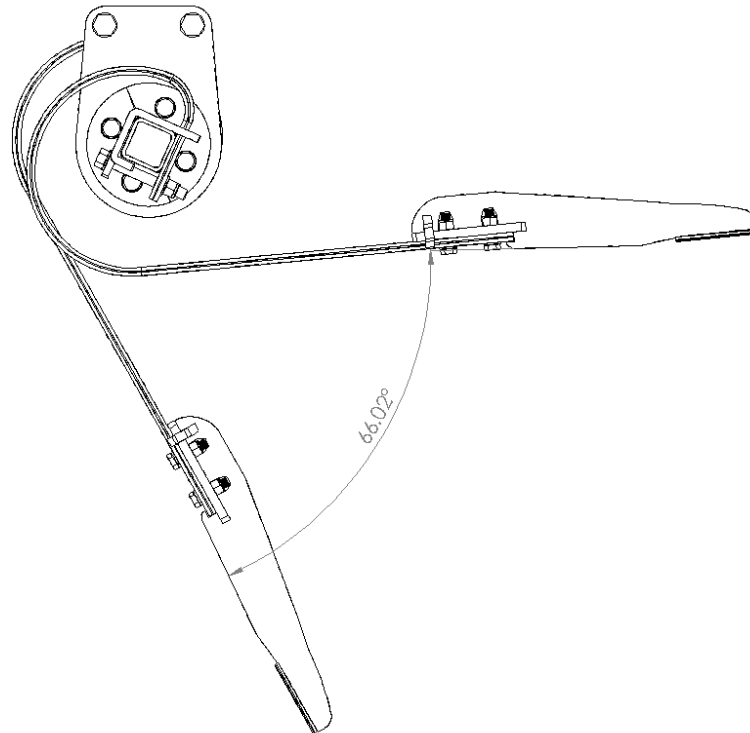

### 8.3 Adjustments – tine spacing

Tines are effectively positioned every 75mm (450mm tine-to-tine on each bar) over the six rows. If the primary aim of use is to distribute large quantities of poorly-spread chopped straw but an increased level of penetration is also desired; then the user may find the six rows of tines all working at maximum aggression tends to hold on to straw for too long without releasing. If not caught soon enough, this can initiate undesirable blockages.

The Strake is equipped with a unique feature whereby every other row of tines can be operated independently and completely removed from work, effectively doubling the tine-to-tine spacing from 75mm to 150mm. This significantly improves trash handling, as well as maintaining a good level of chopped straw distribution.

All tines down 75mm tine-to-tine.

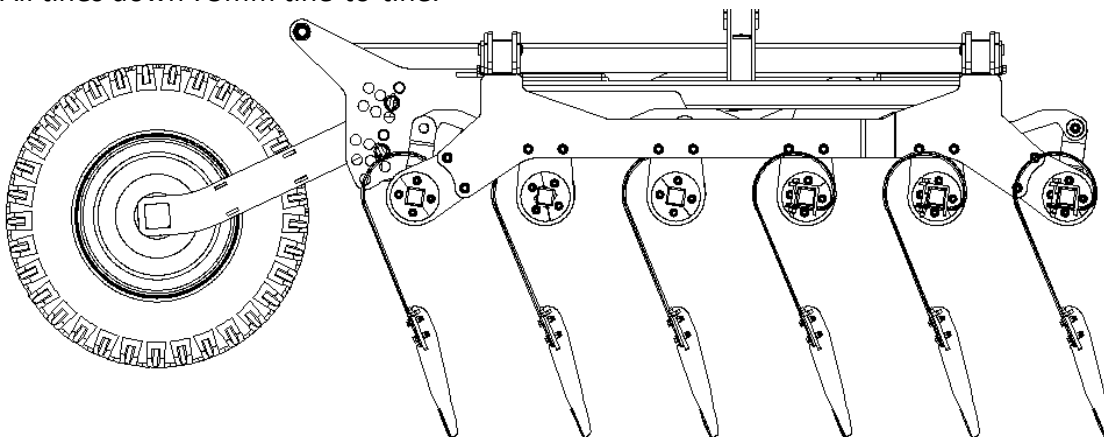

Rows 2, 4 and 6 raised giving 150mm tine-to-tine spacing.

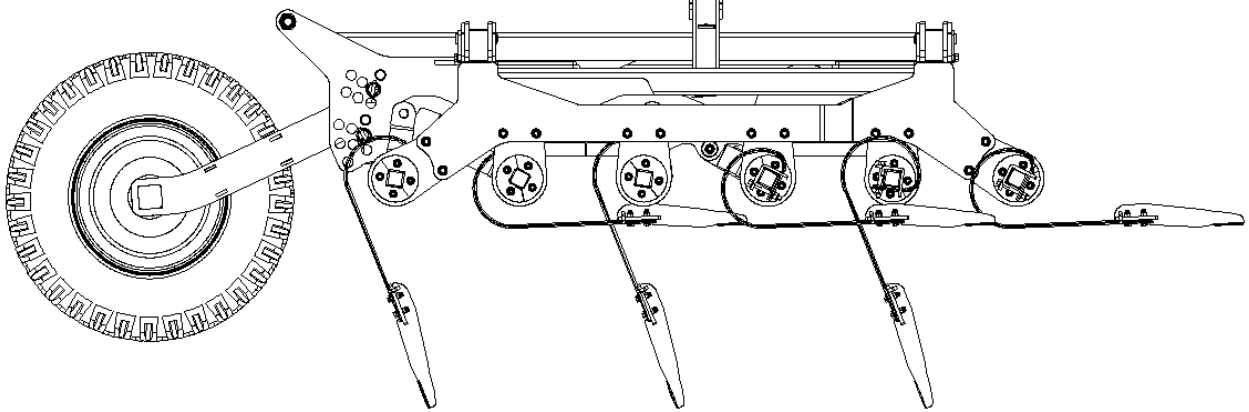

#### 8.4 Adjustments - forward speed

Forward working speed should be governed by the local conditions as well as the finish produced. However, maximum efficiency, in terms of work rate and result, is usually seen between 12-15kph. This figure must be reduced for headland turns.

#### 8.5 Adjustments – wing pressure

Due to the 12m working width and issues relating to field conditions; the Strake is designed to operate with a certain degree of wing movement to allow for effective following of field contours.

This is a controlled function that can be adjusted. The “give” is provided in the way of gas-filled cushioning accumulators. The hydraulic valve shown below controls the resistant pressure in the wing fold cylinders. If more resistance to movement is required, the gold knob should be wound clockwise.

The wings should then be folded in and back out to set the new pressure, N.B. observe the change in pressure, shown on the gauge. Once in their folded-out work position, the spool controlling this function should then be “floated” to relieve any additive back-pressure. The working range is adjustable between 80-150bar.

Wing pressure control valve.

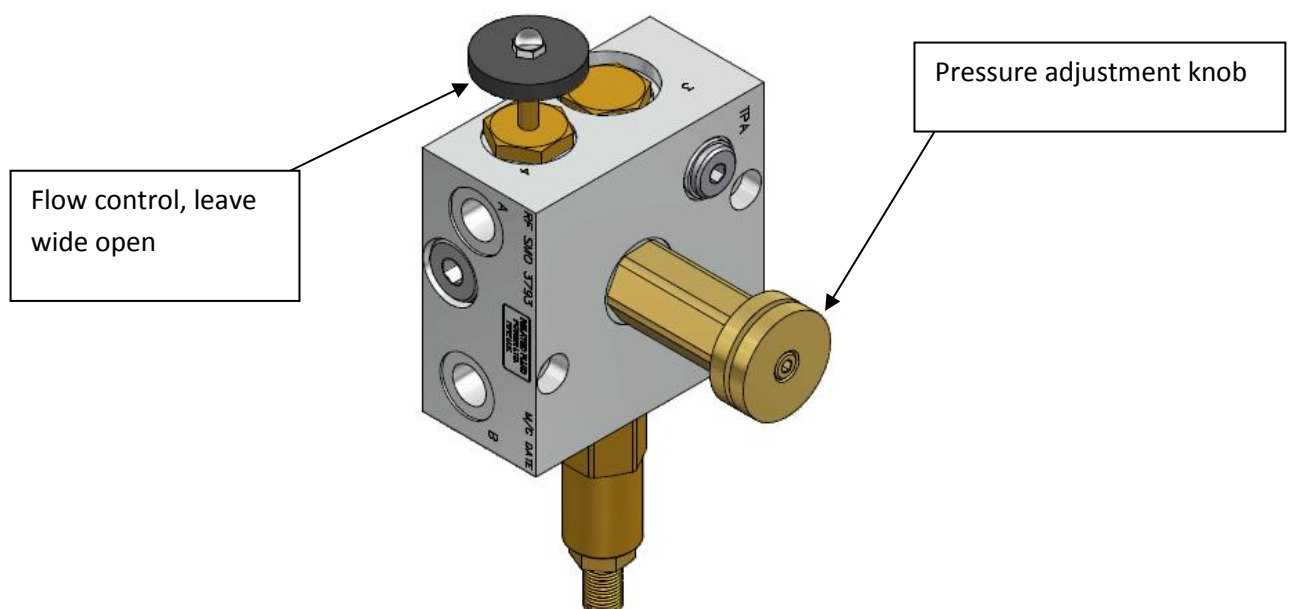

## **9.0 Maintenance**

### **9.1 Maintenance - points**

The condition of the points should be regularly monitored in order to maintain the most efficient use of the machine. Changing of these points must only be done with the wings in one of two positions; either fully folded out or fully folded into the transport position with the wings in their carry cradles. It is essential that the strake is on stable ground and suitably secured against movement i.e. attached to a tractor with the parking brake engage and keys removed.

### **9.2 Maintenance - greasing**

To prolong the life of the Strake and to ensure everything remains adequately lubricated, it is advisable to grease the machine daily (every 12 hours). The grease point locations are detailed below:

- Main lift rams (both ends) – total 4 grease points
- Wing fold rams (both ends) - total 4 grease points
- Tine bar adjustment rams (both ends) - total 16 grease points
- Parallel lift rams (both ends) - total 4 grease points
- Main lift headstock pivot points - total 2 grease points
- Wing fold pivot points – total 2 grease points
- Parallel linkage (top and bottom) – total 4 grease points

### **9.3 Maintenance - storage**

When machines are to be parked up for the winter period, correct storage techniques are an important part of protecting the machine to ensuring a hassle free season. When the machine has finished work it should be cleaned down and washed off to remove all traces of straw/chaff

Following washing off, all grease points located on all rams should receive two or three pumps of grease.

Exposed chrome ram rods on the hydraulic cylinders should also be lightly greased occasionally to prevent these valuable parts from rusting and potentially causing costly oil leaks.

When the machine is parked up a note should be made of what wearing parts require replacing ready for the next seasons work. When ordering replacement parts please have your serial number, part numbers and quantities at hand.

## 10.0 Hydraulic Systems

### 10.1 Circuit diagram; Tine Adjust function (Row nos.1, 3 & 5)

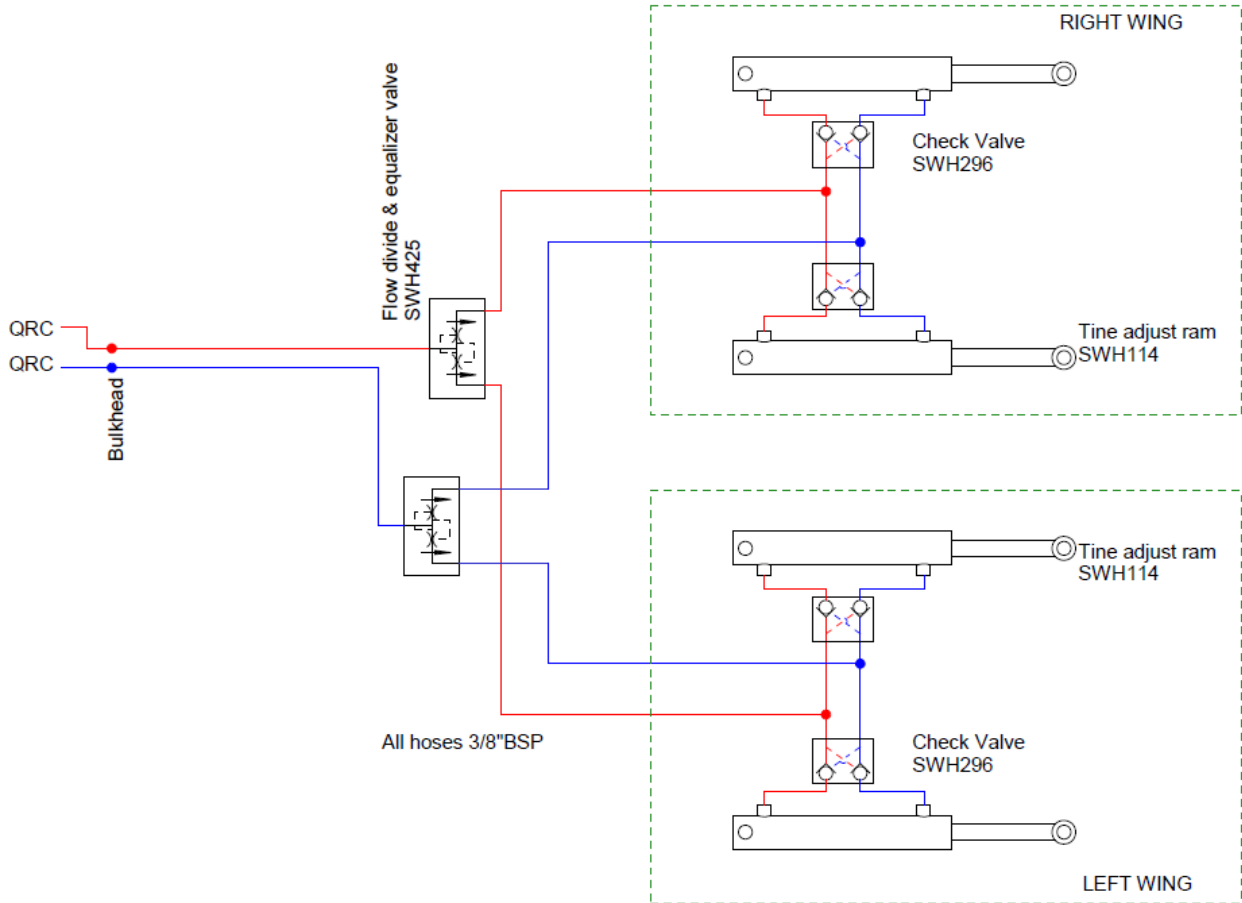

### 10.2 Circuit diagram; Height Adjust function

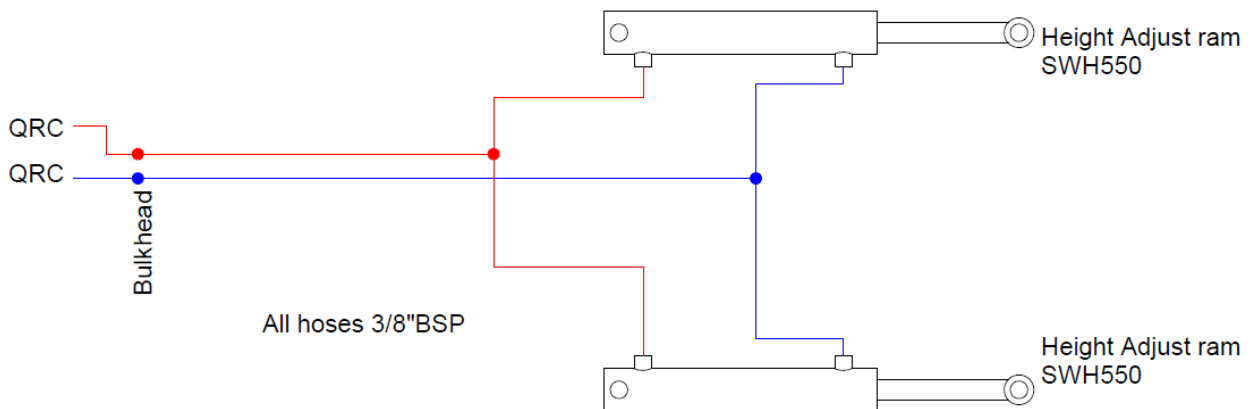

### 10.3 Circuit diagram; Main Lift & Fold

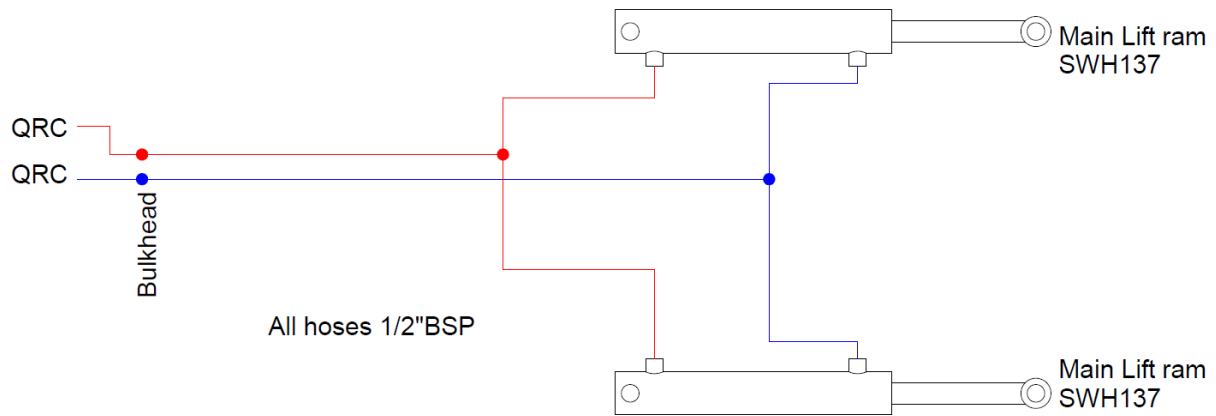

### 10.4 Circuit diagram; Tine Adjust function (Row nos.2, 4 & 6)

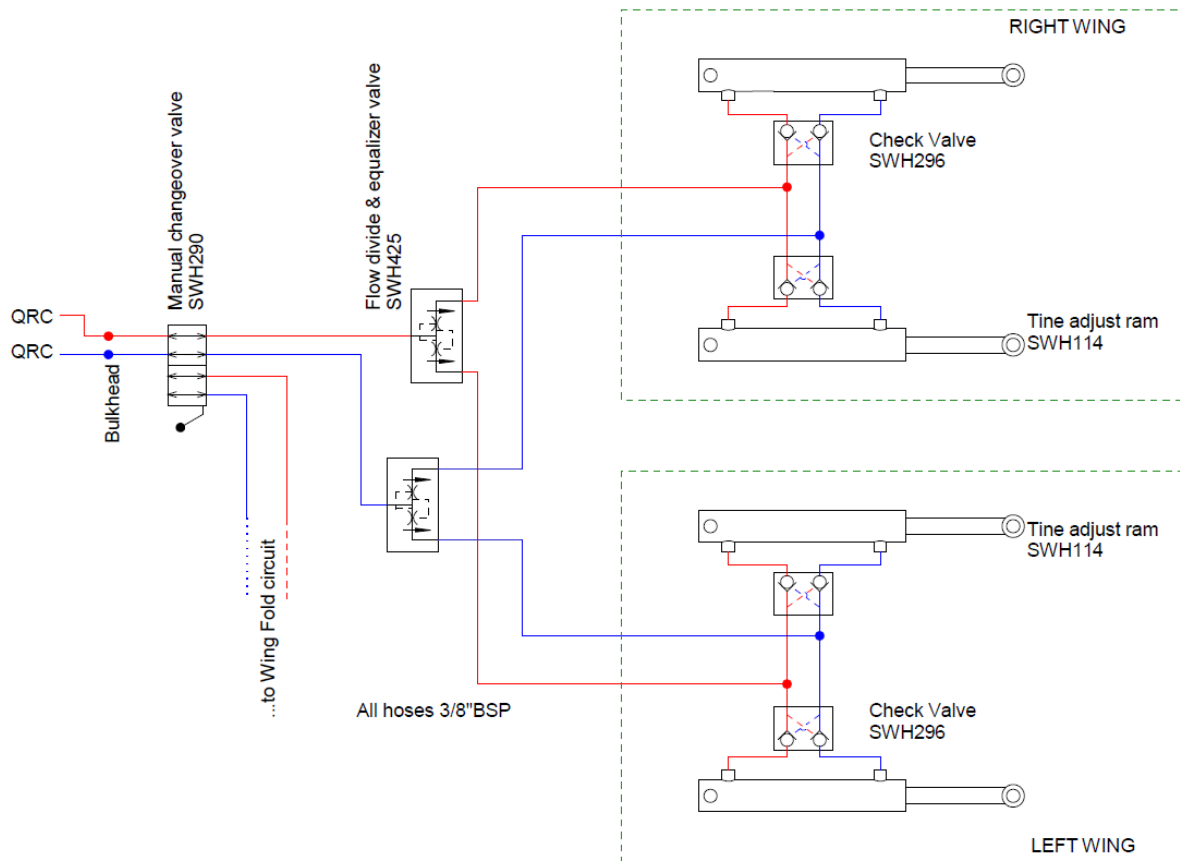

### 10.5 Circuit diagram; Wing Fold

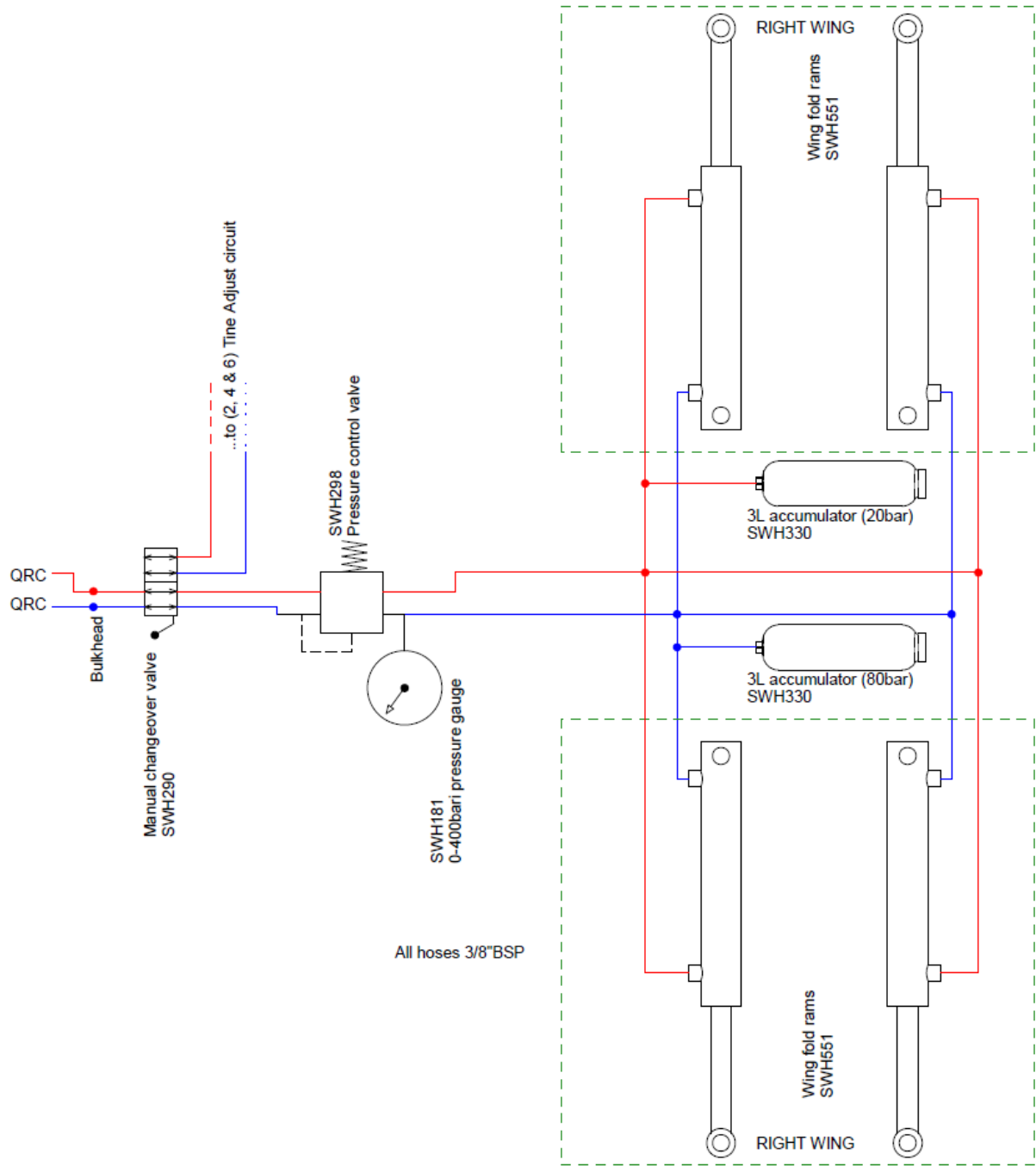



## **11.0 Parts**

The following pages display exploded images of elements of the Sumo Strake. Part numbers are provided for the benefit of ordering spare parts.

# 11.1 Lighting Assembly

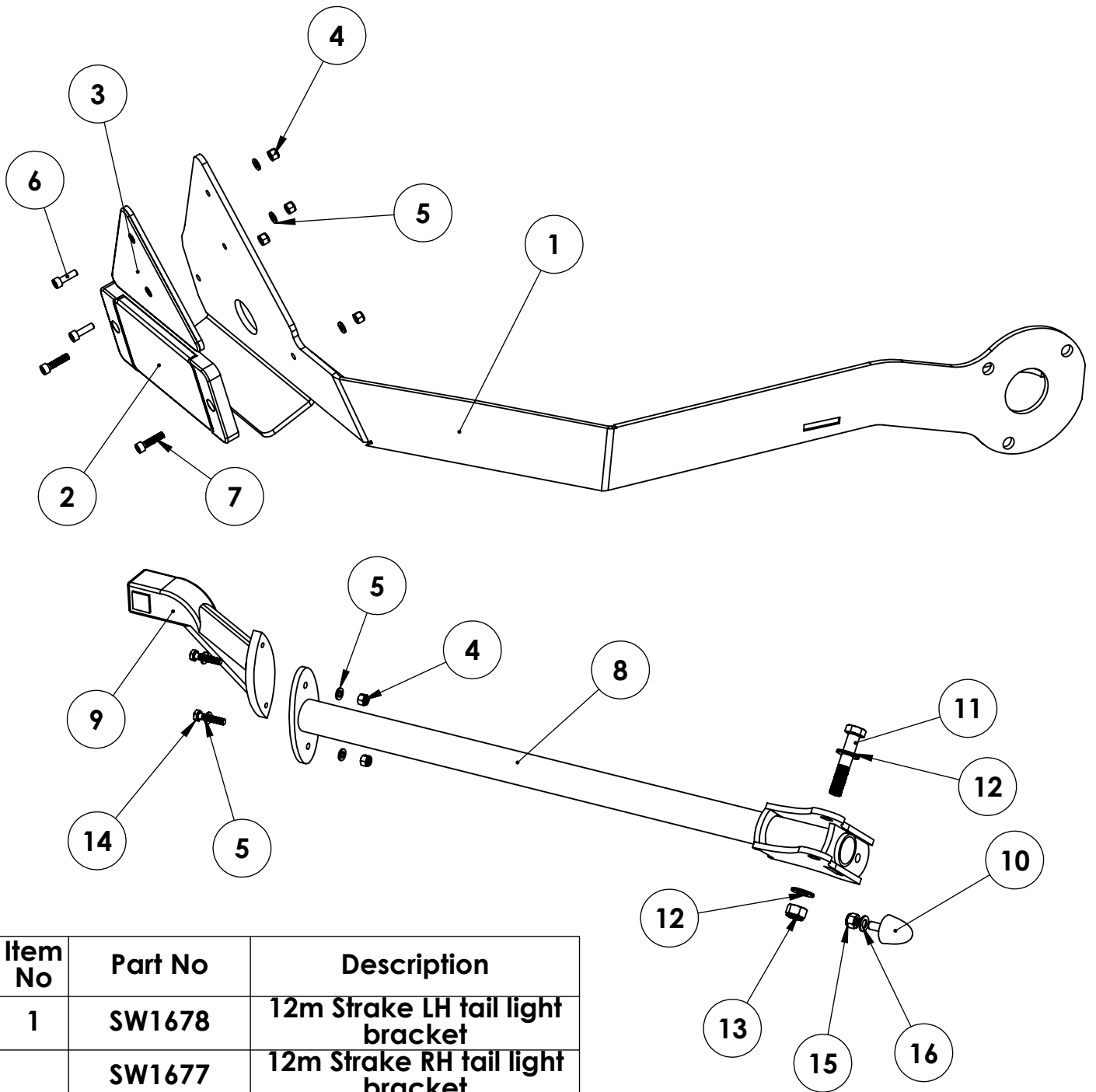

Item No	Part No	Description
1	SW1678	12m Strake LH tail light bracket
	SW1677	12m Strake RH tail light bracket
2	SWB715	LED Rear Light
3	SWB162	Warning Triangle
4	SWM6004	M6 Nylock Nut
5	SWM6001	M6 Washer
6	SWM620SKT	M6 x 20 Socket Head
7	SWM625SKT	M6 x 25 Socket Head
8	SW2252	Sidelight Bracket LH
	SW2253	Sidelight Bracket RH
9	SWB172	Rubberlite LH side light
	SWB173	Rubberlite RH side light
10	SWB574	M8 Bump Stop
11	SWM1265	M12 x 65 Bolt
12	SWM12001	M12 Washer
13	SWM12005	M12 Nylock T Type
14	SWM630	M6 x 30 Bolt
15	SWM8004	M8 Nylock Nut
16	SWM8001	M8 Washer

DO NOT SCALE DRAWING

MACHINE/COMPONENT:

**Sumo Strake**

TITLE:

**Lighting Assembly**



Drawings and design information found herein remain the sole property of Sumo UK Ltd. Reproductions may only be made with the permission of the owner.

SCALE:1:20

REVISION:

DATE: 22/03/16

INITIAL: DC

## 11.2 Tine Pivot Assembly

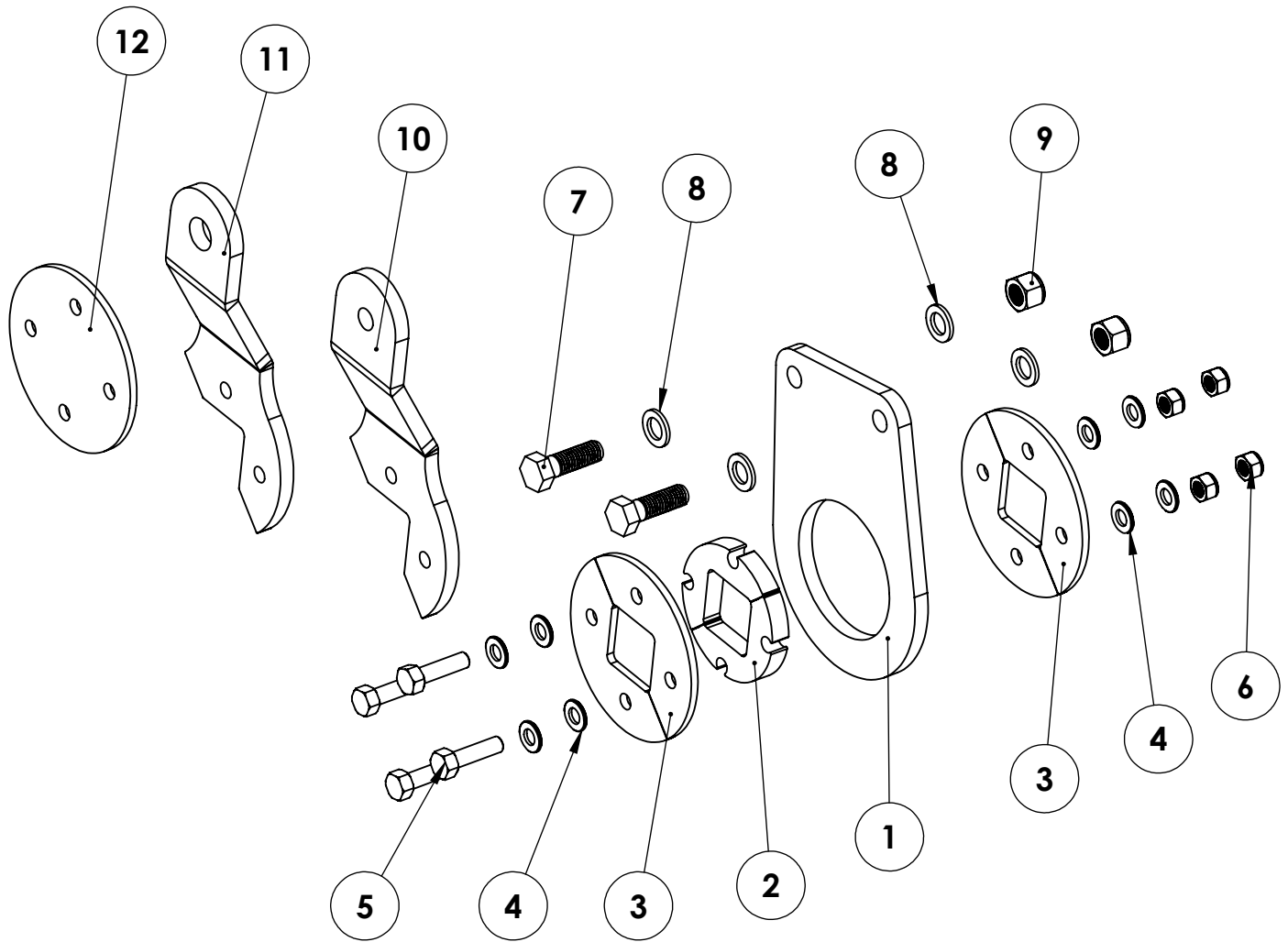

Item No	Part No	Description
1	SW3034	Strake Bolt on Tine Bar pivot
2	SW1303	Inside through tine turn unit profile (strake)
3	SW1302	Internal tine turn unit profile (strake)
4	SWM12001	M12 Washer
5	SWM1245	M12 x 45 Bolt
6	SWM12005	M12 Nylock T Type Nut
7	SWM1650	M16 x 50 Bolt
8	SWM16001	M16 Washer
9	SWM16004	M16 Nylock Nut
10	SWS12276	Strake Tine adjust jogged profile (ram type)
11	SWS12277	Strake Tine adjust jogged profile (normal type)
12	SW1305	External Tine Turn profile

DO NOT SCALE DRAWING

MACHINE/COMPONENT:

**Sumo Strake**

TITLE:

**Tine Pivot Assembly**



Drawings and design information found herein remain the sole property of Sumo UK Ltd. Reproductions may only be made with the permission of the owner.

SCALE:1:20

REVISION:

DATE: 22/03/16

INITIAL: DC

# 11.3 Push-Rod Assembly

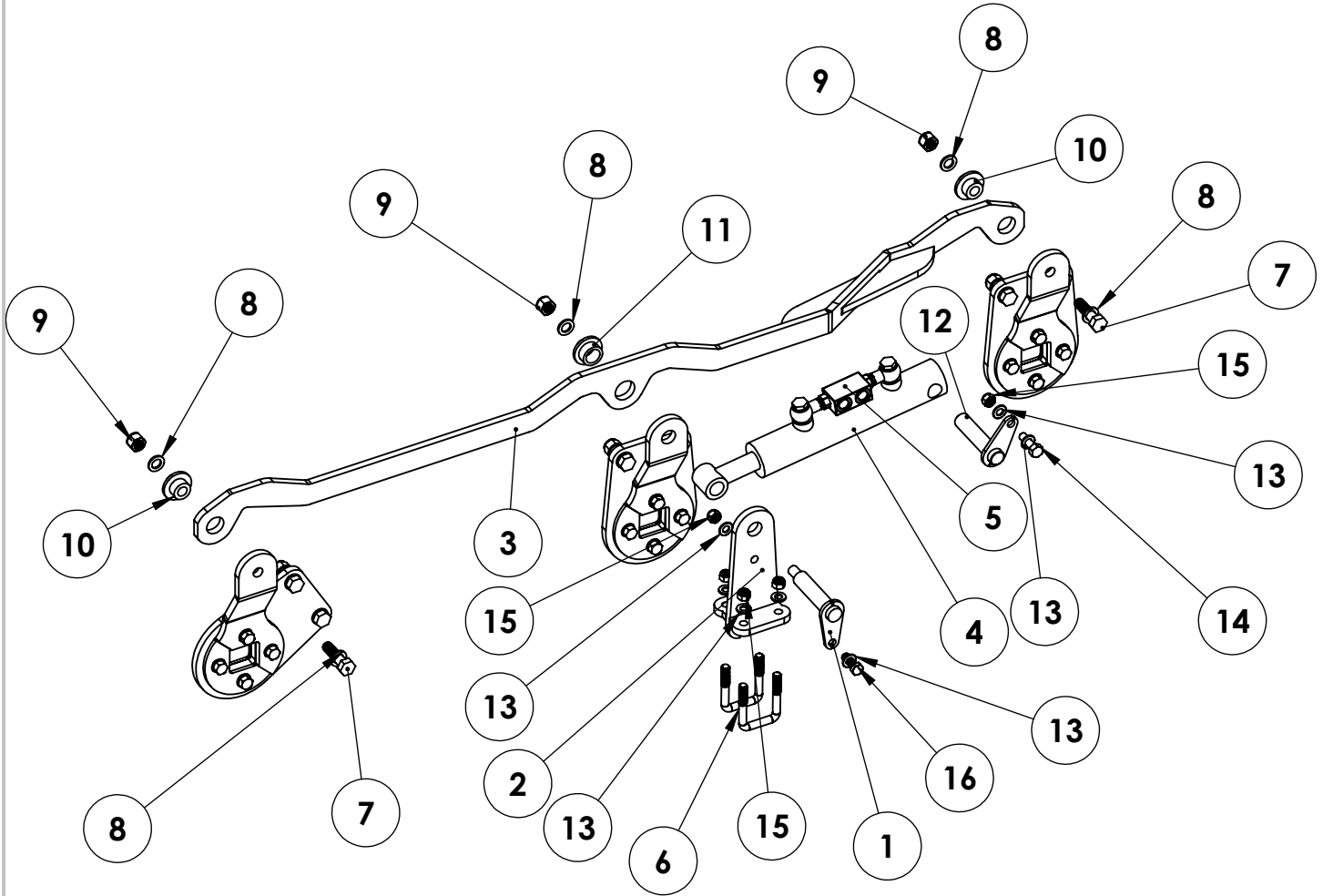

Item No	Part No	Description
1	SWP25x100T	25 x 100 Tabbed Pin Threaded End
2	SW3035	Bolt-on Ram Mount
3	SW3036	Strake fine push rod ram style
	SW3037 (not shown)	Strake fine push rod non-ram style
4	SWH114	702/2 Ram
5	SWH296	Pilot Operated Check Valve
6	SWM1250UB	M12 x 50 U-Bolt
7	SWM1660	M16 x 60 Bolt
8	SWM16001	M16 Washer
9	SWM16004	M16 Nylock
10	SWS12292	Strake push rod bush (non-ram position)
11	SWS12291	Strake push rod bush (ram position)
12	SWP25x105	25x105 Tabbed Pin
13	SWM12001	M12 Washer
14	SWM1240	M12 x 40 Bolt
15	SWM12005	M12 Nylock T-Type
16	SWM1235	M12 x 35 Bolt

DO NOT SCALE DRAWING

MACHINE/COMPONENT:

**Sumo Strake**

TITLE:

**Push Rod Assembly**



Drawings and design information found herein remain the sole property of Sumo UK Ltd. Reproductions may only be made with the permission of the owner.

SCALE:1:50

REVISION:

DATE: 22/03/16

INITIAL: DC

# 11.4 Tine Assembly

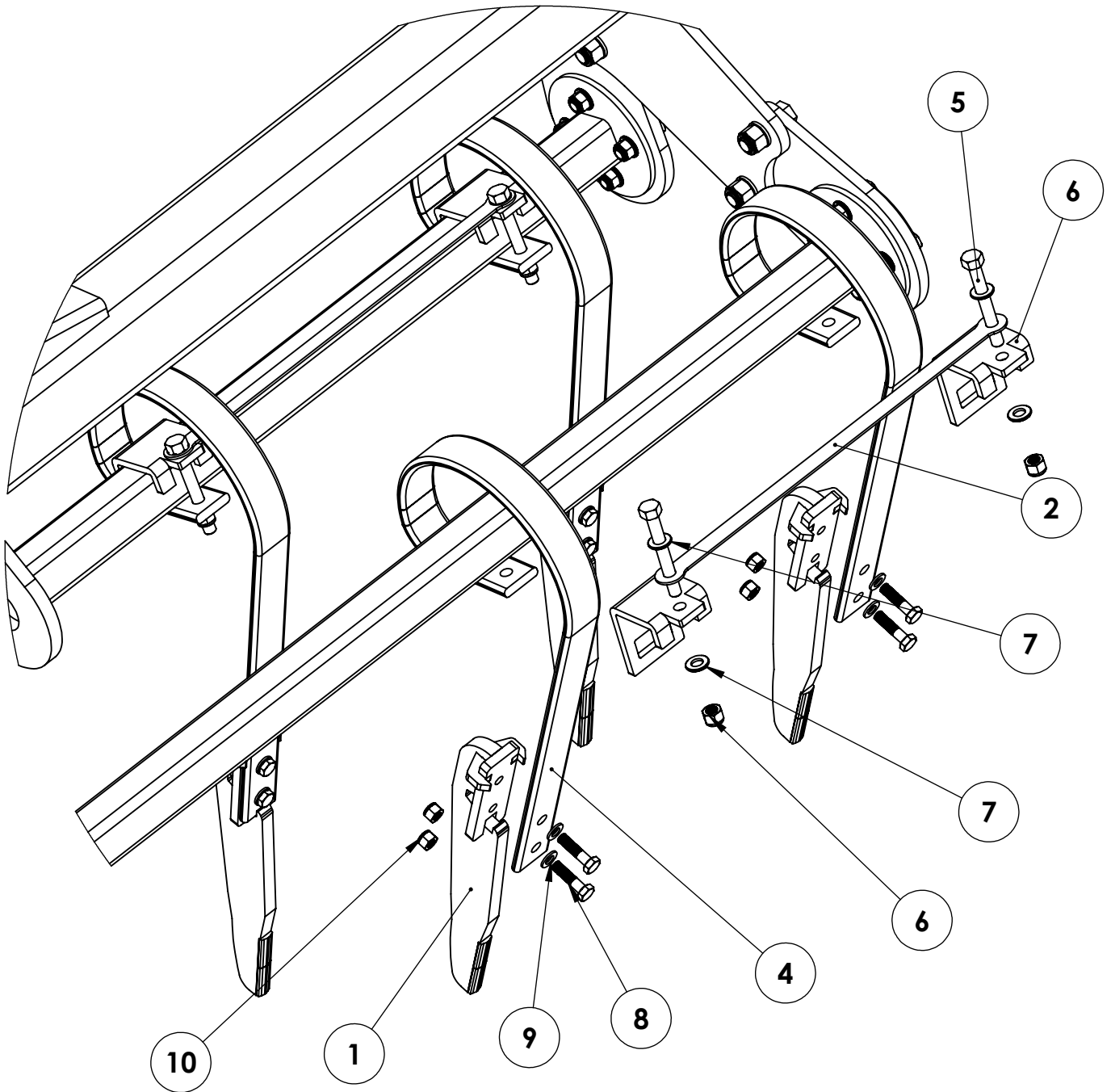

Item No	Part No	Description
1	SW2111	Strake Tine Point
2	SWS10055	Tine Tie Bar
3	SWB453	Tine Clamp
4	SWB272	45x10 Spring Tine
5	SWM12100	M12 x 100 Bolt
6	SWM12004	M12 Nylock Nut
7	SWM12001	M12 Washer
8	SWM1035	M10 x 35 Bolt
9	SWM10001	M10 Washer
10	SWM10004	M10 Nylock Nut

DO NOT SCALE DRAWING

MACHINE/COMPONENT:

**Sumo Strake**

TITLE:

**Tine Assembly**



Drawings and design information found herein remain the sole property of Sumo UK Ltd. Reproductions may only be made with the permission of the owner.

SCALE:1:50

REVISION:

DATE: 22/03/16

INITIAL: DC

# 11.5 Tine Bar Overview

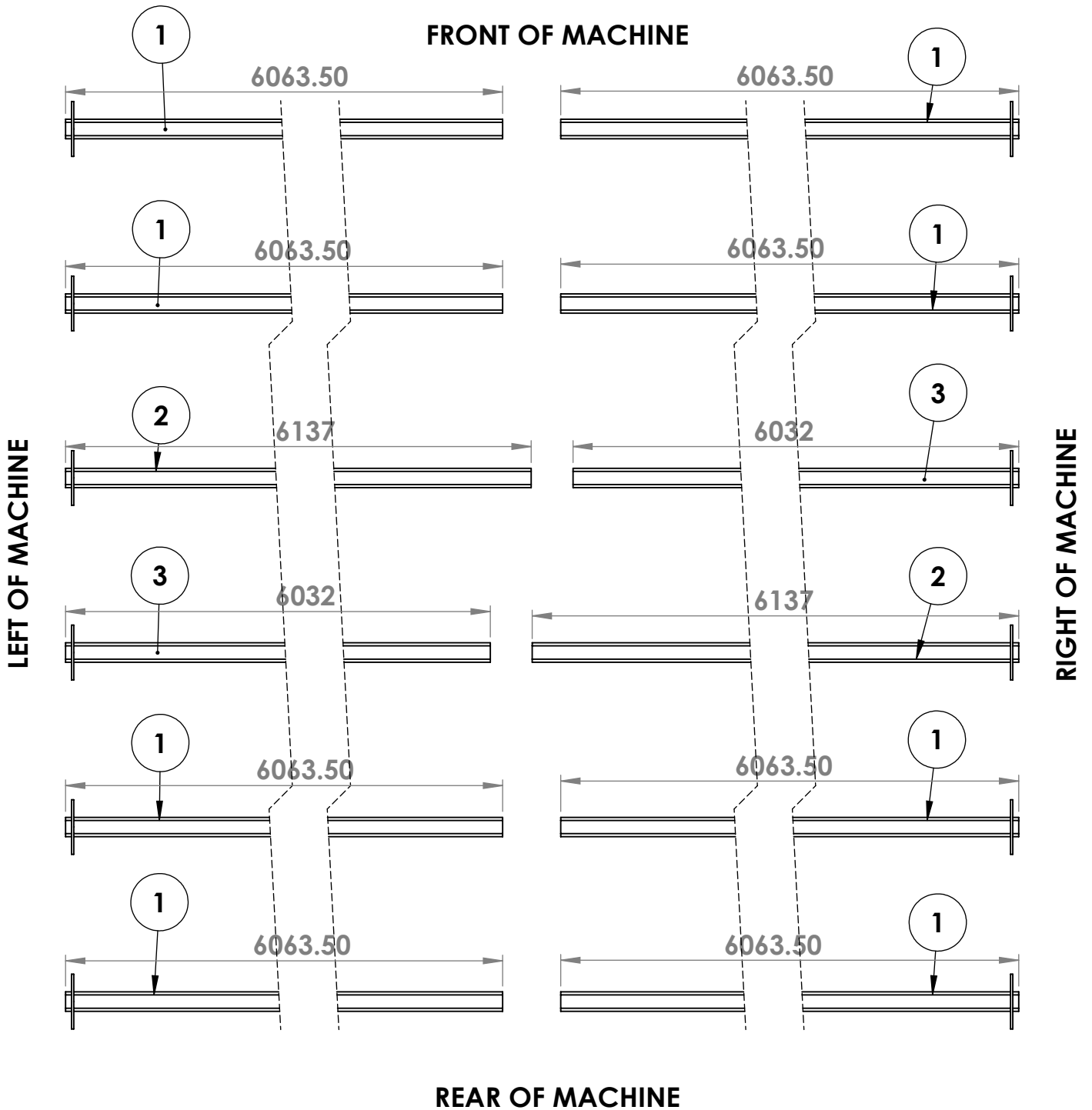

Item No	Part No	Description
1	SW1672	12m Strake tine bar 6063.5mm (x8)
2	SW1673	12m Strake tine bar 6137mm (x2)
3	SW1674	12m Strake tine bar 6032mm (x2)

DO NOT SCALE DRAWING	
MACHINE/COMPONENT: <b>Sumo Strake</b>	
TITLE: <b>Tine Bar Overview</b>	
Drawings and design information found herein remain the sole property of Sumo UK Ltd. Reproductions may only be made with the permission of the owner.	
SCALE: 1:200	REVISION:
DATE: 22/03/16	INITIAL: DC

## 11.6 Headstock and Parallel Arms

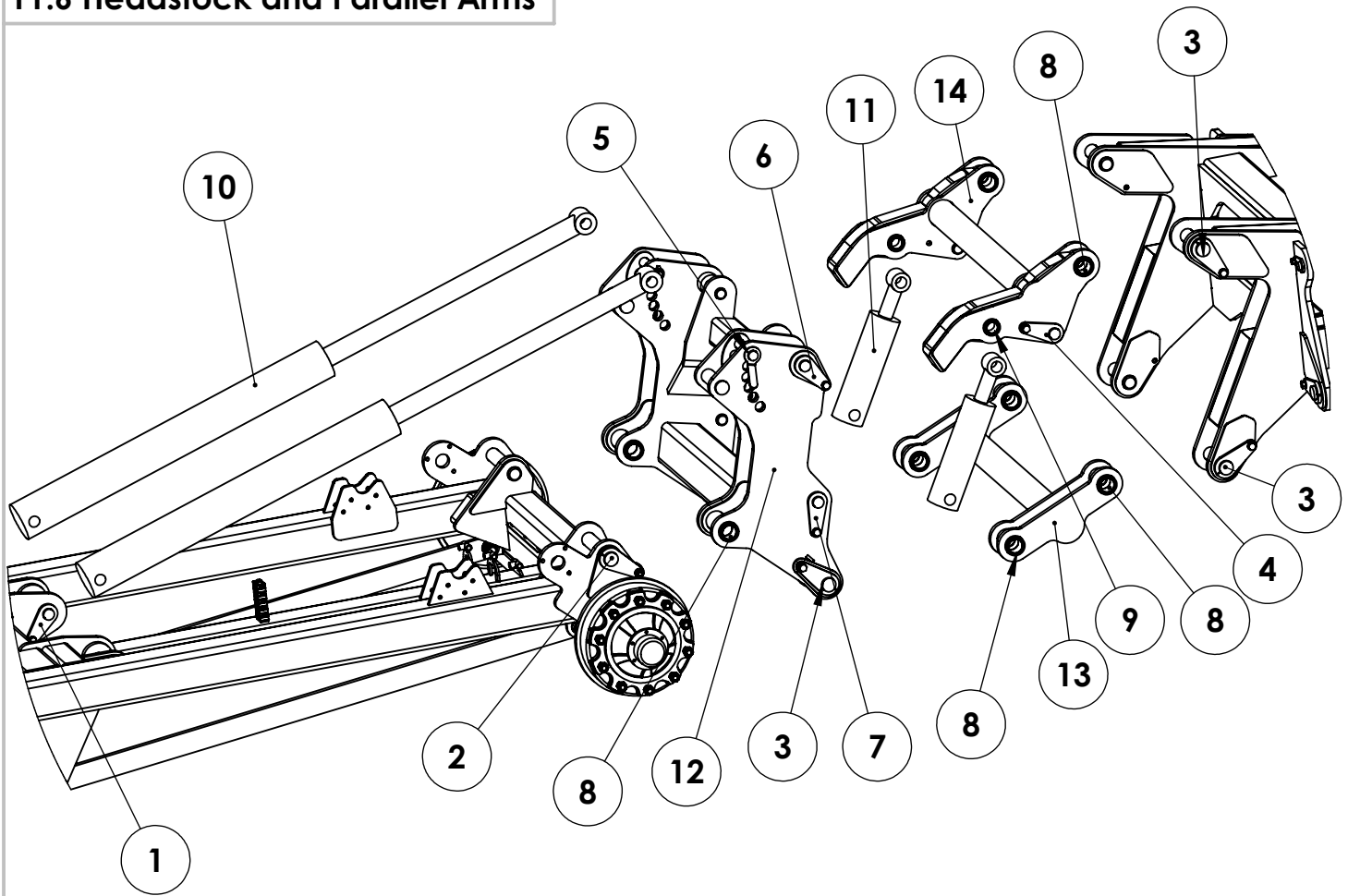

Item No	Part No	Description
1	SWP40x260	40 x 260 Tabbed Pin
2	SWP 50x310	50 x 310 Tabbed Pin
3	SWP50x220	50 x 220 Tabbed Pin
4	SWP40x130	40 x 130 Tabbed Pin
5	SWP35x215H	35 x 215 Handled Pin
6	SWP40x370	40 x 370 Tabbed Pin
7	SWP40x200	40 x 200 Tabbed Pin
8	SWB142	50x50x58 Oilite bush
9	SWB757	40x50x40 Oilite bush
10	SWH137	707-10 Ram
	SWH292	707 Seal kit
11	SWH550	706-2 Ram
	SWH355	706 Seal Kit
12	SW1665	12m Strake carriage
13	SW1670	12m Strake lower parallel link
14	SW1671	12m Strake upper parallel link

DO NOT SCALE DRAWING

MACHINE/COMPONENT:

**Sumo Strake**

TITLE:

**Headstock and Parallel Arms**



Drawings and design information found herein remain the sole property of Sumo UK Ltd. Reproductions may only be made with the permission of the owner.

SCALE:1:500

REVISION:

DATE: 22/03/16

INITIAL: DC

## 11.7 Wing and Headstock Overview

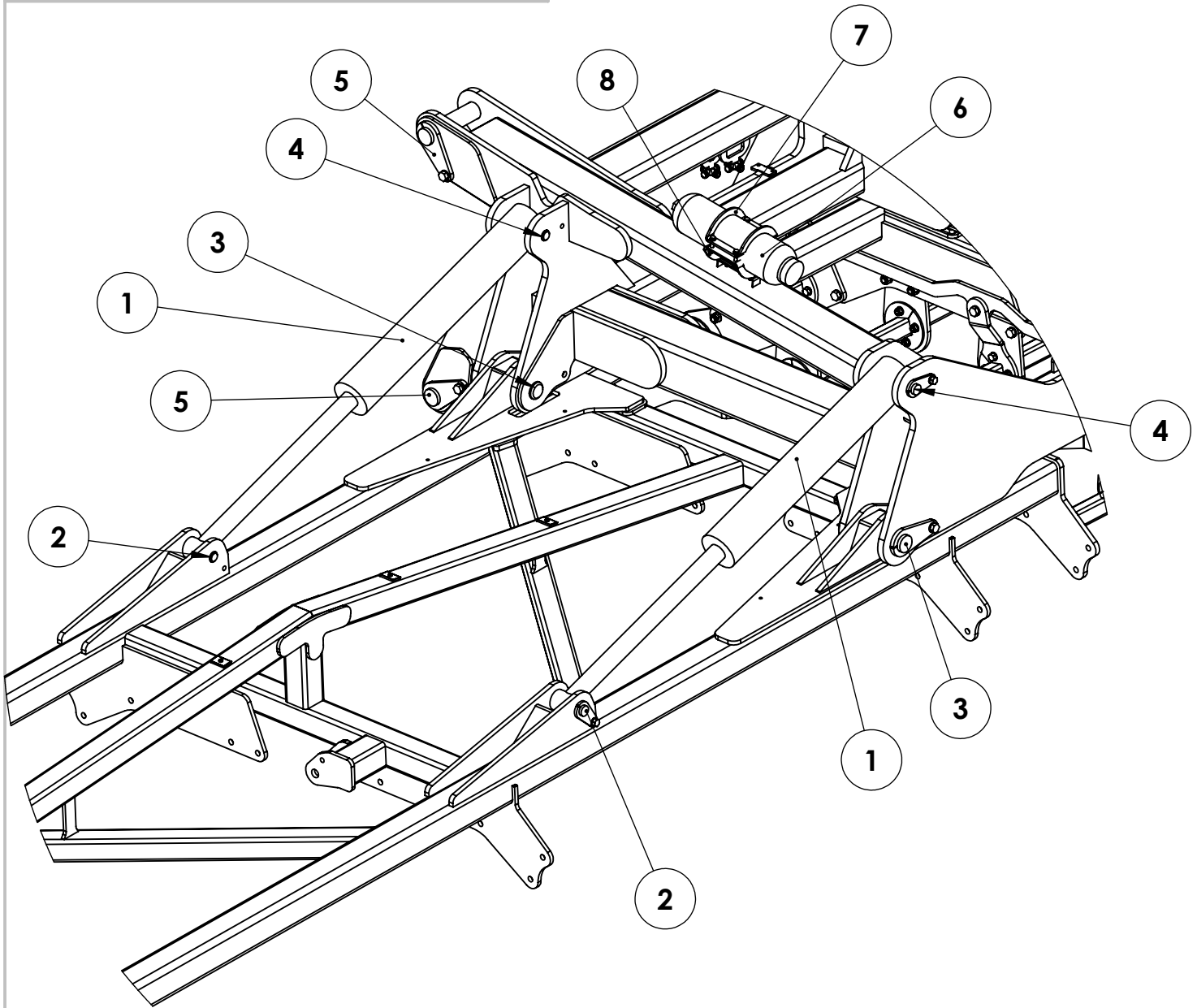

Item No	Part No	Description
1	SWH551	706-6 Ram
	SWH315	706 Seal Kit
2	SWP30x110	30 x 110 Tabbed Pin
3	SWP50x185	50 x 185 Tabbed Pin
4	SWP30x170	30 x 170 Tabbed Pin
5	SWP50x220	50 x 220 Tabbed Pin
6	SWH330	3L 80 Bar Accumulator
7	SW1510	Acumulator Bracket Top
8	SW1511	Acumulator Bracket Bottom

DO NOT SCALE DRAWING

MACHINE/COMPONENT:

**Sumo Strake**

TITLE:

**Wing and Headstock Overview**



Drawings and design information found herein remain the sole property of Sumo UK Ltd. Reproductions may only be made with the permission of the owner.

SCALE:1:200

REVISION:

DATE: 22/03/16

INITIAL: DC

# 11.8 Depth wheel Assembly

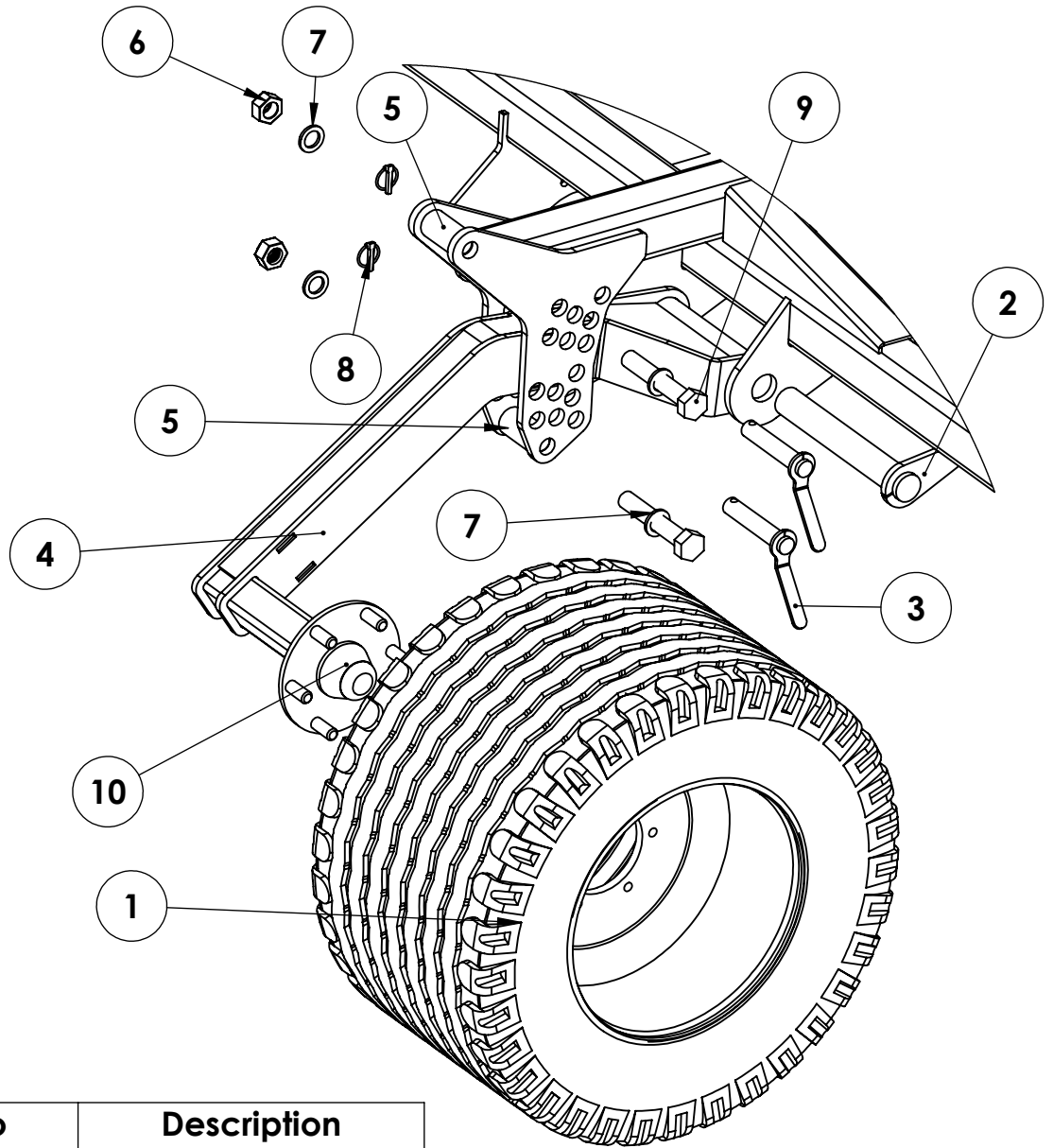

Item No	Part No	Description
1	SWB187	Depth wheel and tyre
2	SWP50x340	50 x 340 Tabbed Pin
3	SWP30x155H	30 x 155 Handled Pin
4	SW1675	LH Strake depth wheel arm
	SW1676	RH Strake depth wheel arm
5	SWS12293	12m Strake Wing catcher roller
6	SWM3004	M30 Nylock Nut
7	SWM30001	M30 Washer
8	SWB105	Lynch Pin
9	SWM30180	M30 x 180 Bolt
10	SWB252	Depth Axle Outer Bearing
	SWB256	Depth Axle Inner Bearing

DO NOT SCALE DRAWING

MACHINE/COMPONENT:

**Sumo Strake**

TITLE:

**Depth wheel Assembly**



Drawings and design information found herein remain the sole property of Sumo UK Ltd. Reproductions may only be made with the permission of the owner.









SCALE:1:200

REVISION:

DATE: 22/03/16

INITIAL: DC

### 11.9 Decals

	231x62mm horizontal	Su001
	59x235mm Vertical	Su002
	101x51mm Reflective	Su003
	350x94mm horizontal	Su004
	179x670mm horizontal	Su005
	25 x 15mm	SU047
	25 x 15mm	SU048
	80 x 160mm Stop Engine	SU033
	80 x 160mm Unfolding	SU034
	51 x 101mm Reflective Vertical	SU050
	80 x 70mm	SU040
	80 x 70mm	SU041
	75 x 47mm	SU042
	457 x 98mm	SU054
	28 x 35mm	SU031
	80 x 160mm No Riding on Machines	SU032