

# **SUMO** **STRAKE**



6.0m and 8.0m machines

## **2016** **Operator Manual** **and** **Parts List**

**SUMO**  
**UK LIMITED**  
Agricultural Machinery Manufacturers

[www.sumo1.com](http://www.sumo1.com)

Redgates  
Melbourne  
York  
YO42 4RG  
Tel. 01759 319900  
Fax. 01759 319901



## 1.0 Registration

**To activate your SUMO Warranty**, you must complete this page and send it back to us at:

Sumo UK Ltd  
Redgates  
Melbourne  
York  
YO42 4RG  
Tel. 01759 319900  
Fax. 01759 319901

**(NO REGISTRATION = NO WARRANTY)**

SUMO SERIAL No:  
For your own records.



### Sumo Strake Registration Document

NAME:

ADDRESS:

Postcode:

Telephone Number:

DATE:

SUMO SERIAL No.  
(Serial plate on  
side of headstock)

DEALERSHIP  
NAME AND  
BRANCH:

COMMENTS:



**In order to obtain your free pair of Sumo overalls and baseball cap** please fill in this form and send back to us at:

Sumo UK Ltd  
Redgates  
Melbourne  
York  
YO42 4RG  
Tel. 01759 319900  
Fax. 01759 319901



SUMO SERIAL No:

Overall size:  
tick where applicable

Small (38 chest)	
Medium (42 chest)	
Large (46 chest)	
Extra large (50 chest)	
XX Large (54 chest)	
XXX Large (58 chest)	

NAME:

ADDRESS:



## **2.0 Summary**

The Sumo Strake is a versatile machine which offers a multitude of benefits. The even distribution of chaff and straw combined with mixing with soil is essential when encouraging the growth of unwanted seeds including black grass.

The 15mm carbide tips, combined with powerful spring tines prove an ideal combination when wanting to achieve a shallow tilth. This disturbance will provide the ideal conditions for the rouge seeds to chit.

The superior frame build quality and tine design allows forward speeds of 10 – 25 kmh giving unrivalled performance even in the hardest ground

The Sumo Strake prepares the stubble for the next pass which makes drilling, cultivating or ploughing easier due to even trash distribution.

Before using the Sumo Strake it is absolutely necessary that you read this Operators Manual and Safety Instructions attentively.

Specifications, descriptions and illustrations in this brochure are accurate, as known, at the time of publication but may be subject to change.



## Table of Contents

<b>1.0 Registration</b> .....	<b>2</b>
<b>2.0 Summary</b> .....	<b>4</b>
<b>3.0 Safety</b> .....	<b>6</b>
<b>4.0 Operation and Adjustment</b> .....	<b>8</b>
<b>5.0 Maintenance</b> .....	<b>13</b>
<b>5.1 Spares</b> .....	<b>13</b>
<b>5.2 Winter storage</b> .....	<b>13</b>
<b>6.0 Parts and Assembly</b> .....	<b>13</b>
<b>6.1 Headstock</b> .....	<b>14</b>
<b>6.2 Wing assembly</b> .....	<b>15</b>
<b>6.3 Tine bar turn unit</b> .....	<b>16</b>
<b>6.4 Tine bar pushrod</b> .....	<b>17</b>
<b>6.5 Tine and points</b> .....	<b>18</b>
<b>6.6 Wing hydraulics</b> .....	<b>19</b>
<b>6.7 6m Strake tine hydraulics</b> .....	<b>20</b>
<b>6.8 8m Strake tine hydraulics</b> .....	<b>21</b>
<b>6.9 Light and arm bracket</b> .....	<b>22</b>
<b>6.10 Stickers and paint</b> .....	<b>23</b>

## **3.0 Safety**

This manual contains basic advice which should be observed during setting-up, operation and maintenance. Therefore, this operating manual must be read by the personnel concerned prior to starting up, using the machine and be available at all times.

If safety instructions are not complied with, then this can lead to the risk of injury to yourself and others as well as damage to the environment or the machine. Non-compliance to the safety instructions can also lead to claims for damages becoming invalid.

### **3.1 Qualification and Training**

- Ensure that only reliable, authorized personnel work on or with the machine. Statutory minimum age limits must be observed.
- Employ only trained or instructed staff; the individual responsibilities of the personnel concerning operation, setting up, maintenance and repair must be clearly established.
- Define the machine operators' responsibilities – also with regard to observing traffic regulations. The operator must have the authority to refuse any instructions issued by third parties, which contravene safety.
- Persons undergoing training or instruction or taking part in a general training course should not be allowed to work on or with the machine unless they are under the constant supervision of an experienced person.
- The use of spare parts, accessories and ancillary equipment not supplied and/or not approved by SUMO could have detrimental effects to the construction of the SUMO machine or on its functions and hence impair the active and/or passive driving and/or operational safety (accident prevention).
- SUMO shall not be responsible for any damage caused by the use of spare parts, accessories and ancillary equipment not supplied and/or approved by SUMO.
- Conversions of or modifications to the machine may only be carried out after consultation with SUMO.

### 3.2 General safety

- Warning signs and other notices on the machine provide important information for the safe operation. Observing them will serve your safety.
- Before starting work, make yourself familiar with all the equipment and controls as well as their functions.
- The user should wear close-fitting clothing.
- Keep the machine and if applicable the bearings clean to avoid risk of fire.
- Check around the machine before moving off or starting up (watch out for children!). Make sure you have adequate all-round visibility.
- Always match your speed to the local conditions. Avoid sudden turning manoeuvres when driving uphill or downhill or when travelling across a slope.
- Observe the respective regulations when using public roads.
- Take into account the wide overhang and/or the sideways force acting on the machine when turning or negotiating curves.
- Take into account the height of the folded machine when in transport mode. **BEWARE OF OVERHEAD OBSTRUCTIONS.**

### 3.3 Special safety instructions

- Take extreme care when hitching up or unhitching machine to/from the tractor.
- Never allow persons to stand between the tractor and the machine unless the tractor is secured against rolling away by means of parking brake and/or wheel chocks.
- During transport, secure the packer (using both pins) to prevent shock loading when encountering road undulations. Ensure stands are raised to their transport position.
- It is forbidden to allow persons to ride on the machine at any time. A safe distance should be maintained from the machine by observers when in work.
- Driving, steering and braking characteristics are influenced by mounted machines and ballast weights. Therefore, ensure adequate steering and braking ability.
- Never stand or work beneath suspended loads. **Ensure stands are in the lowered position before commencing maintenance work or adjustment on the Tine/points.** Ensure ground conditions are able to support the weight of the machine on the stands.
- If there is a requirement to lift the Sumo Strake, appropriate lifting apparatus must be attached through a lifting eye in the centre of the machine. The 8m Strake weighs approximately 2800kg.
- When making adjustments to the machines care should be taken not to trap any body parts in moving or pivoting parts.

### Top Link Pin

Due to the physical nature and weight distribution of the Sumo Strake a **category three enclosed ball top link** is highly recommended.

Due to the exaggerated loads experienced during normal working conditions, the top link pin is considered as a consumable part and should be checked for wear on a regular basis.



## **4.0 Operation and Adjustment**

### **4.1 Operation**

Before attaching a Strake to a tractor it is essential that the **stands are in the down position** to ensure a short top link when attached. Once attached securely to the tractor the machine can then be raised and the stands lifted out of the way. When the machine is removed from the tractor it is equally important to leave the machine on the stands.

The top link should be as short as possible whilst remaining as close to horizontal as is achievable. It is important to ensure the machine is running level to allow the optimum level of soil disturbance as well as to prolong the life of the wearing parts.

Changing the points on the Strake must only be done on level ground. When it is deemed necessary to change the points, the stands should be lowered to the static position and other appropriate jacks, stands and chocks put into position in sensible locations. To avoid the risk of sinking and potential injury it is important to **only change the points where ground conditions permit**, i.e. solid concrete, tarmac etc. Care should be taken to ensure the Strake is firmly and safely held before changing the points. The tractor engine must be turned off with the parking brake applied.

### **4.2 Adjustments**

The Strake is a very simple machine with minimal adjustments required.

Forward working speed should be governed by the local conditions as well as the finish produced by the Sumo strake.

There are two basic adjustments available. Firstly, the tractor linkage can be lifted or lowered to alter frame clearance and pressure on the tines and secondly the angle of the spring tine can be varied to increase or reduce the aggression/effect of the points.

### **Folding and Unfolding Procedure**

When folding the machine out from transport position please ensure that the wing tie bars are removed and that all stands are in their highest position. Also tines must be in work position when folding and unfolding

You can also lift every other row of tines out of work if the conditions dictate



## **5.0 Maintenance**

The condition of the points should be regularly monitored in order to maintain the most efficient use of the machine.

The condition and position of the points/tines should also be observed in order to prevent straw building up.

Hydraulic cylinders - Exposed chrome ram rods should also be lightly greased occasionally to prevent these valuable parts from rusting and causing costly oil leaks.

## **5.1 Spares**

When ordering replacement parts please have your serial number, part numbers and quantities at hand.

## **5.2 Winter storage**

When machines are to be parked up for the winter period, correct storage techniques are an important part of protecting the machine to ensure a hassle free season. When the machine has finished work it should be cleaned down and washed off to remove all traces of straw/chaff

Following washing off grease points located on all rams should receive two or three pumps of grease.

When the machine is parked up a note should be made of what wearing parts require replacing ready for the next seasons work. The wearing parts can then be ordered in time ready for the next season's work in good time to avoid delays when the machine is required earlier than expected!

## 6.1 Headstock

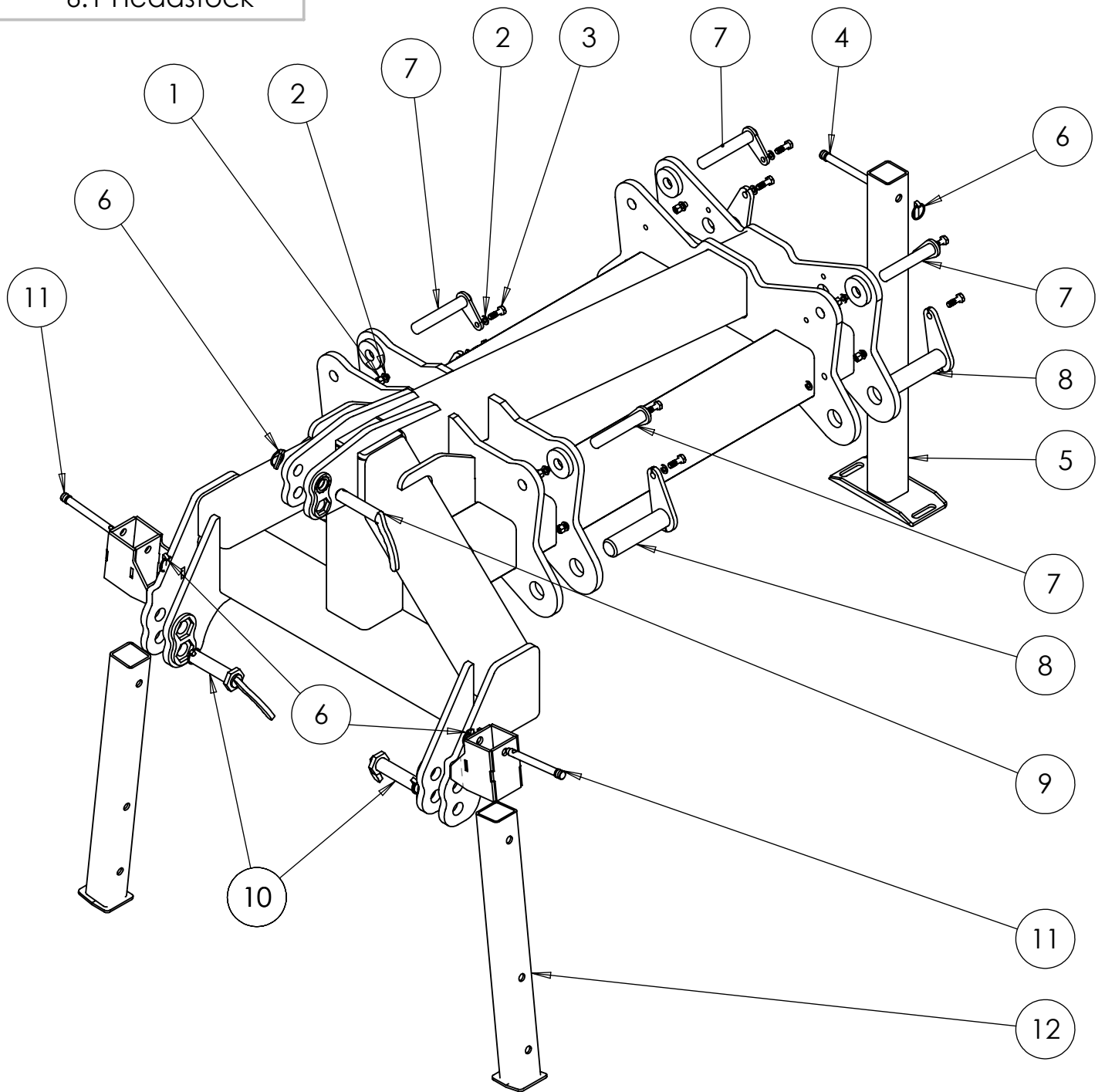

ITEM NO.	PART NO.	DESCRIPTION
1	SWM12004	M12 Nylock Nut
2	SWM12001	M12 Flat Washer
3	SWM1240	M14 x 40 Bolt
4	SW118	Rear Stand Pin
5	SW1296	Strake Rear Stand
6	SW576	Cat IV Safety Lynch Pin
7	SW1297	30 x 175 Tabbed Pin
8	SW1298	50 x 216 Tabbed Pin
9	SW627	Cat III Hex Top Link Pin
10	SW626	Cat III Hex Bottom Link Pin
11	SW269	Front Stand Pin
12	SW1157	Strake Front Stand

DO NOT SCALE DRAWING

MACHINE/COMPONENT:

SUMO STRAKE

TITLE:

# Headstock



Drawings and design information found herein remain the sole property of Sumo UK Ltd. Reproductions may only be made with the permission of the owner.

REVISION:

DATE: 19/02/14

INITIAL: TW

## 6.2 Wing Assembly

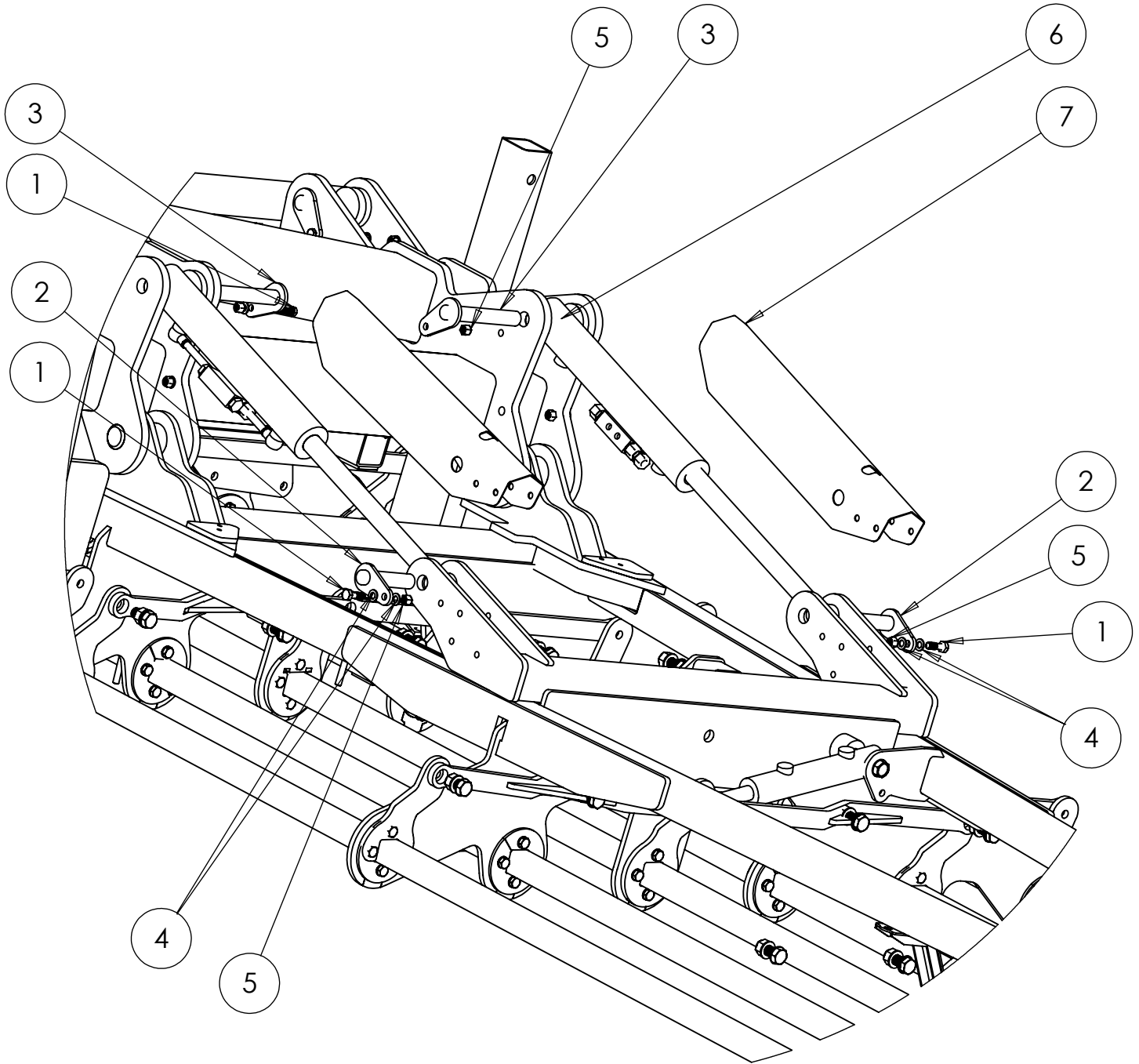

ITEM NO.	PART NO.	DESCRIPTION
1	SWM1240	M12 x 40 Bolt
2	SW336	30 x 125 Tabbed Pin
3	SW660	30 x 165 Tabbed Pin
4	SWM12001	M12 Flat Washer
5	SWM12004	M12 Nylock
6	SWH377	704/4 Ram
7	SW1299	Ram Guard Stone Protector

DO NOT SCALE DRAWING

MACHINE/COMPONENT:

Sumo Strake

TITLE:

Wing Assembly



Drawings and design information found herein remain the sole property of Sumo UK Ltd. Reproductions may only be made with the permission of the owner.

REVISION:

DATE: 20/02/14

INITIAL: TW

### 6.3 Tine bar turn unit

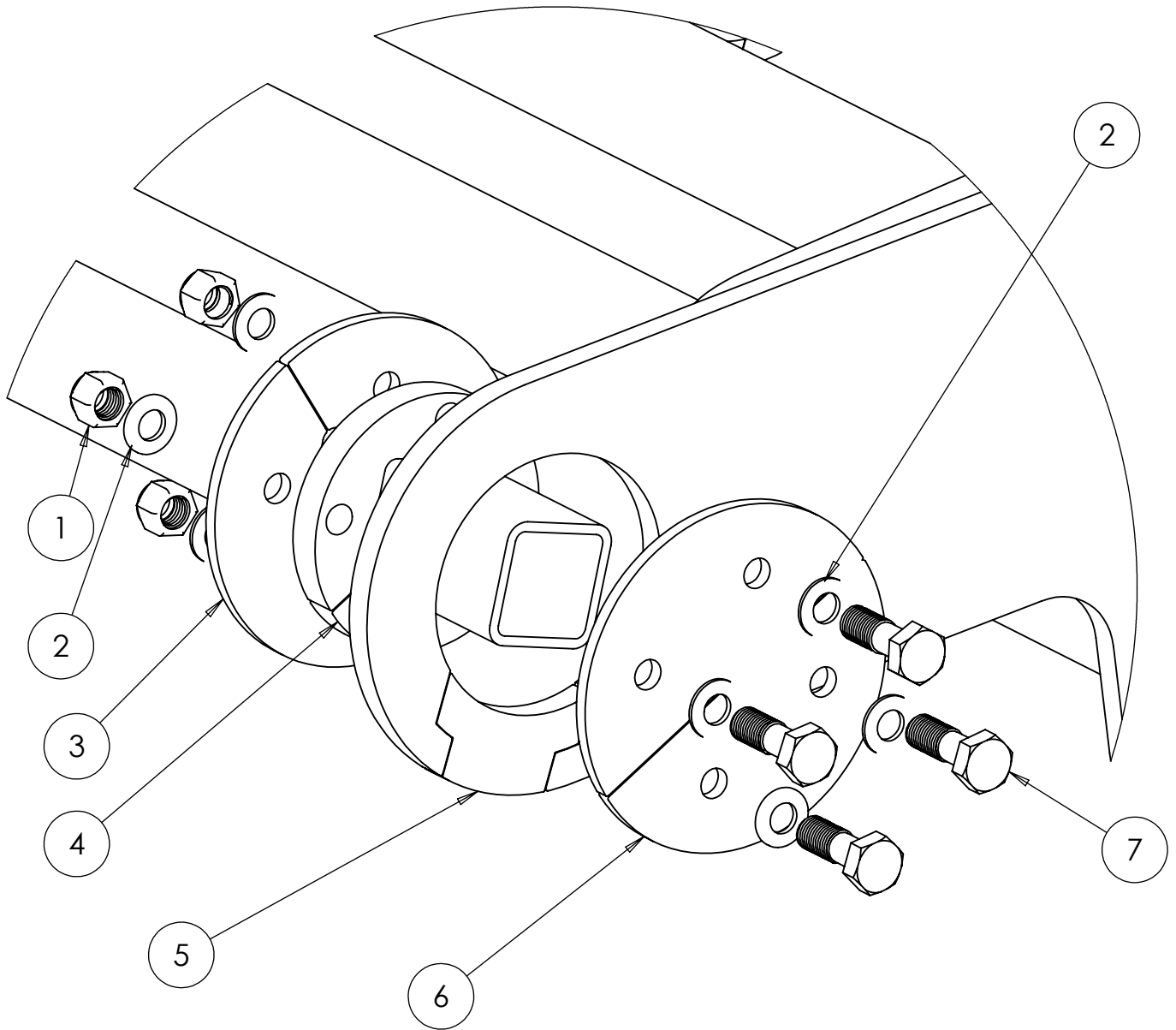

ITEM NO.	PART NO.	DESCRIPTION
1	SWM12004	M12 NYlock Nut
2	SWM12001	M12 Flat Washer
3	SW1302	Internal Tine Turn Unit Profile
4	SW1303	Inside Through Tine Turn Unit Profile
5	SW1304	Locking T Piece
6	SW1305	External Tine Turn Profile
7	SWM1240	M12x40 Bolt

DO NOT SCALE DRAWING

MACHINE/COMPONENT:

Sumo Strake

TITLE:

Tine Bar Pivots



Drawings and design information found herein remain the sole property of Sumo UK Ltd. Reproductions may only be made with the permission of the owner.

REVISION:

DATE: 20/02/14

INITIAL: TW

## 6.4 Tine bar push rod

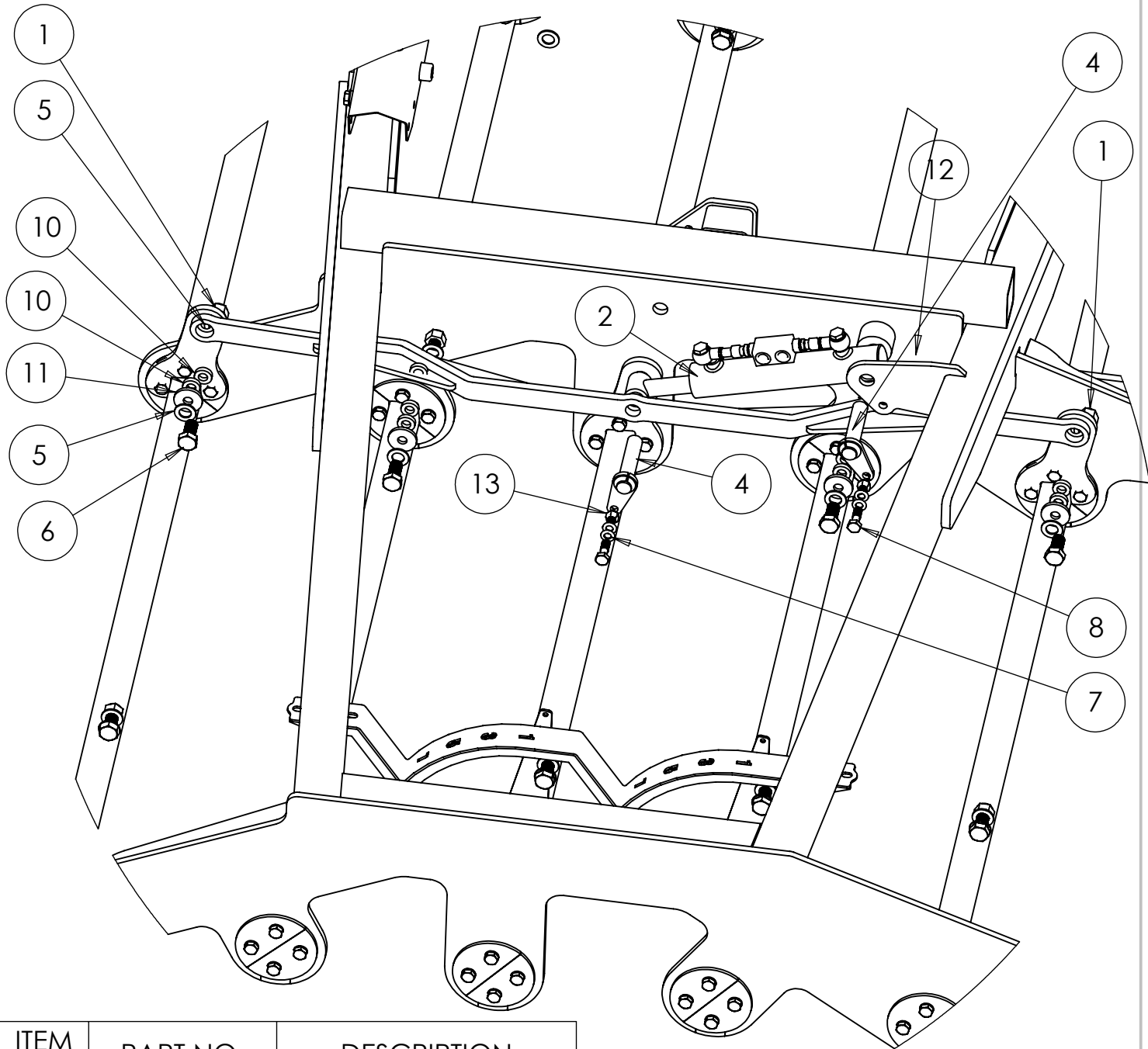

ITEM NO.	PART NO.	DESCRIPTION
1	SWM16004	M16 Nylock Nut
2	SWH114	702/2 Ram
3	SW1300	Tine Bar Push Rod
4	SW1306	25 x 100 Tabbed Pin
5	SWM16001	M16 Flat Washer
6	SWM1660	M16 x 60 Bolt
7	SWM12001	M12 Flat Washer
8	SW1240	M12 x 40 Bolt
9	SW1250	M12 x 50 Bolt
10	SW1313	30x 8 Washer
11	SW1314	50 x 6 Washer
12	SWH296	Pilot Operated Check Valve
13	SWM12004	M12 Nylock Nut

DO NOT SCALE DRAWING

MACHINE/COMPONENT:

Sumo Strake

TITLE:

Tine bar push rod breakdown



Drawings and design information found herein remain the sole property of Sumo UK Ltd. Reproductions may only be made with the permission of the owner.

REVISION:

DATE: 20/02/14

INITIAL:

TW

## 6.5 Tine Break down

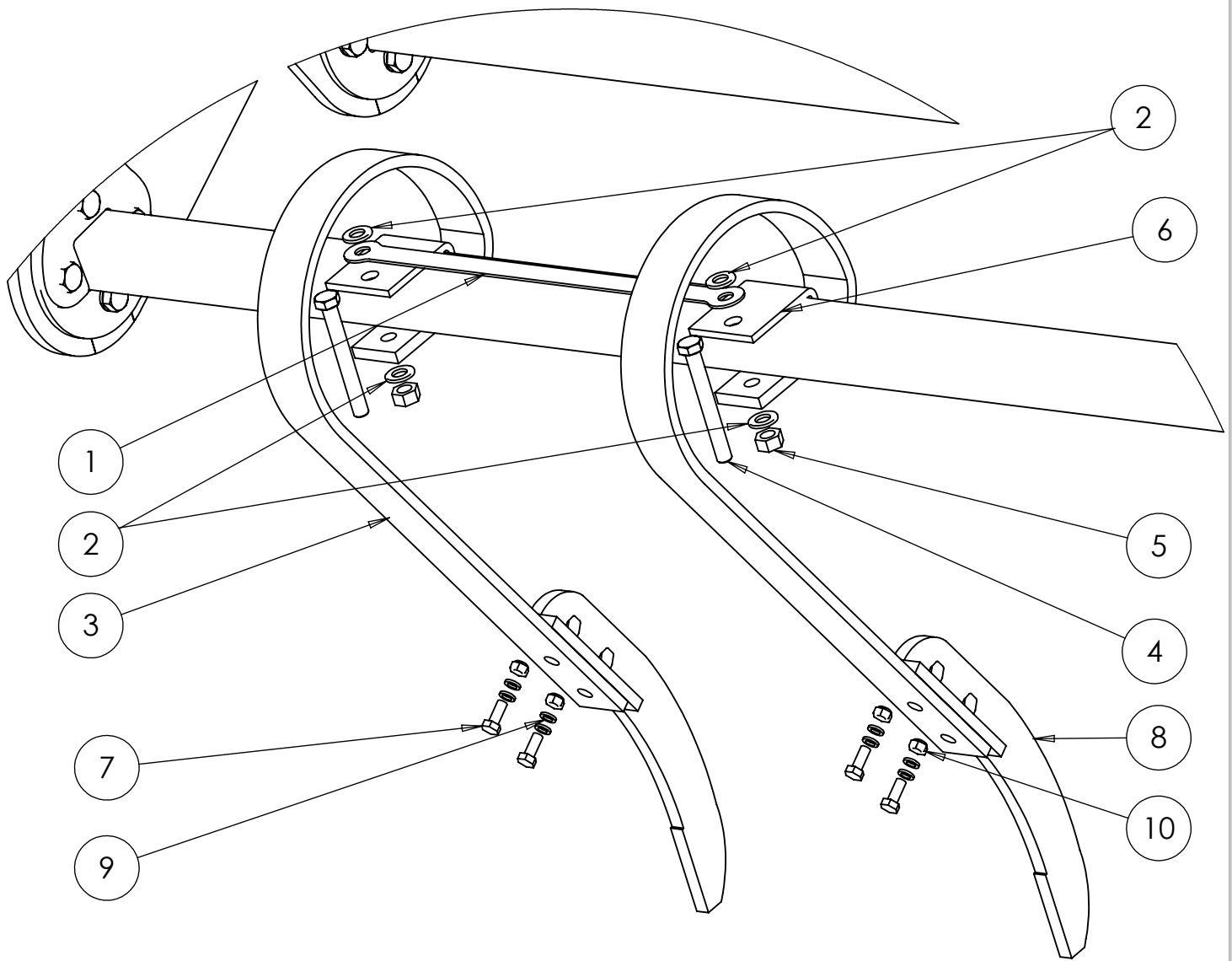

ITEM NO.	PART NO.	DESCRIPTION
1	SW1300	Tine Tie Bar
2	SW12001	M12 Flat Washer
3	SWB272	45 x 10 SPring Tine
4	SWM152110	M12 x 110 Bolt
5	SW12004	M12 Nylock Nut
6	SWB453	Tine Clamp
7	SWM1035	M10 x 35 Bolt
8	SW1205	Strake Tine Point
9	SW10001	M10 Flat Washer
10	SWM10004	M10 Nylock Nut

DO NOT SCALE DRAWING

MACHINE/COMPONENT:

Sumo Strake

TITLE:

Tine Break down



Drawings and design information found herein remain the sole property of Sumo UK Ltd. Reproductions may only be made with the permission of the owner.

REVISION:

DATE: 20/02/14

INITIAL: TW

## 6.6 wing hydraulics

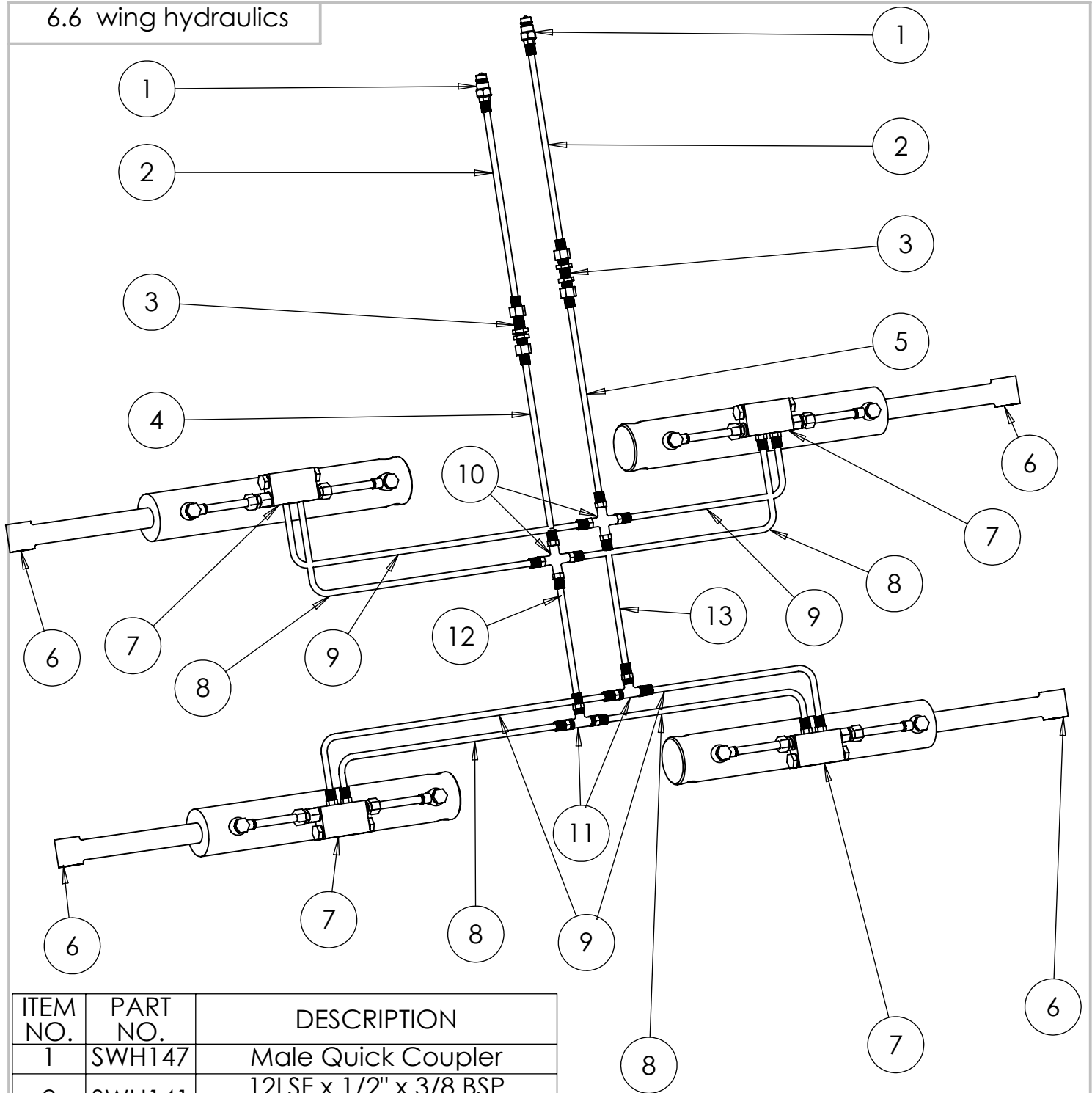

ITEM NO.	PART NO.	DESCRIPTION
1	SWH147	Male Quick Coupler
2	SWH141	12LSF x 1/2" x 3/8 BSP Hydraulic Pipe
3	SWH158	12L Bulckhead Fitting
4	SWH454	12LSD x 1/2" x 3/8 BSP Hydraulic Pipe
5	SWH455	12LSD x 1/2" x 3/8 BSP Hydraulic Pipe
6	SWH377	704/4 Ram
7	SWH154	Pilot Operated Check Valve
8	SWH456	12LSD x 1/2" x 3/8 BSP Hydraulic Pipe
9	SWH457	12LSD x 1/2" x 3/8 BSP Hydraulic Pipe
10	SWH155	12L Cross Junction
11	SWH156	12L Tee Branch
12	SWH458	12LSF x 1/2" x 3/8 BSP Hydraulic Pipe
13	SWH459	12LSF x 1/2" x 3/8 BSP Hydraulic Pipe

DO NOT SCALE DRAWING

MACHINE/COMPONENT:

Sumo Strake

TITLE:

Wing Hydraulics



Drawings and design information found herein remain the sole property of Sumo UK Ltd. Reproductions may only be made with the permission of the owner.

REVISION:

DATE: 20/02/14

INITIAL:

TW

6.7 6m Strake tine hydraulics

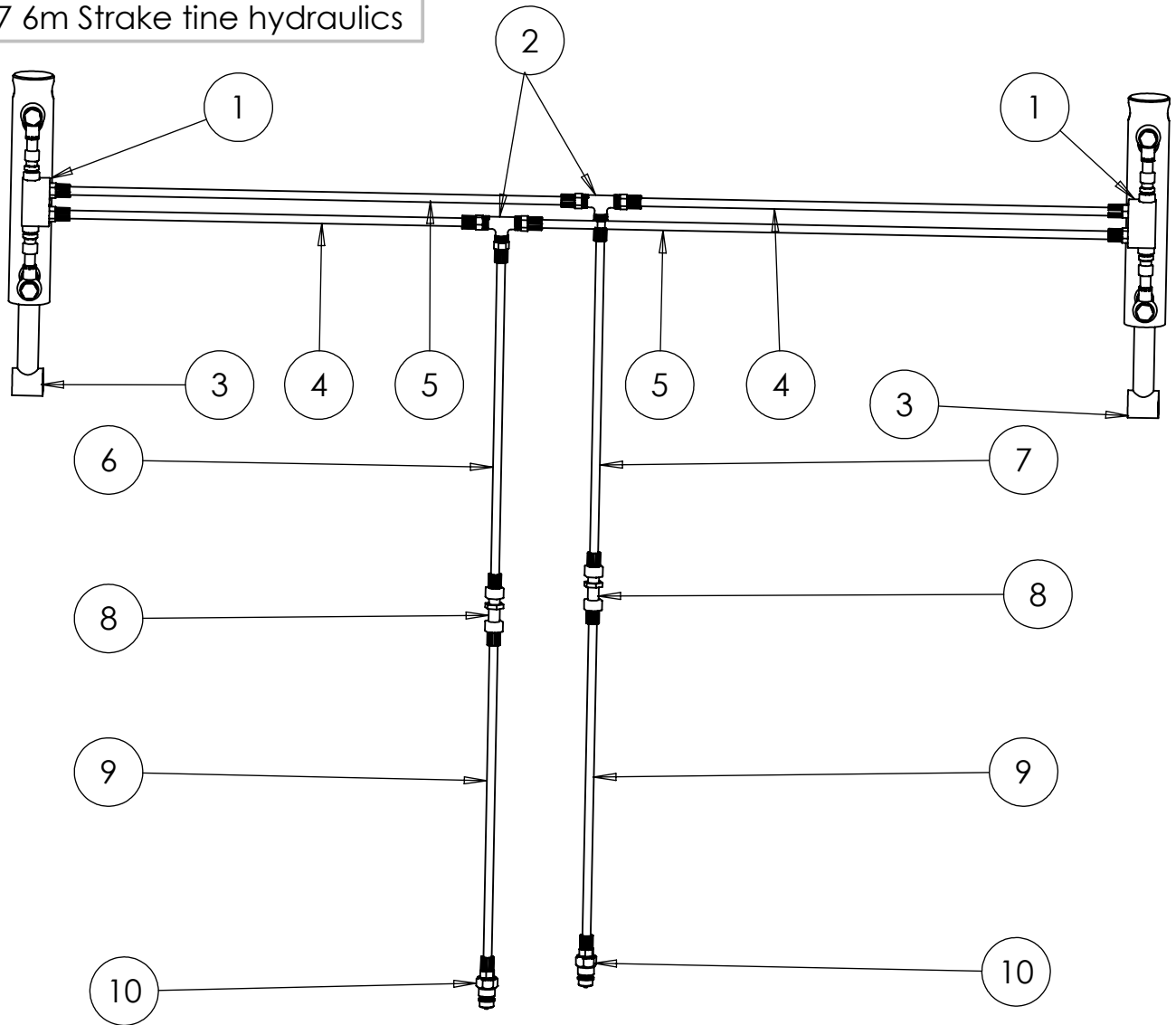

ITEM	PART NO	DESCRIPTION
1	SWH456	pilot operated check valve
2	SWH156	12L Tee branch
3	SWH107	702-2 ram
4	SWH460	Wing tine hydraulic pipe 2600mm
5	SWH461	Wing tine hydraulic pipe 2700mm
6	SWH462	Wing tine hydraulic pipe 930mm
7	SWH463	Wing tine hydraulic pipe 850mm
8	SWH158	12L Bulkhead fitting
9	SWH464	Wing tine hydraulic pipe 1600mm
10	SWH147	male quick couple spool valve

DO NOT SCALE DRAWING	
MACHINE/COMPONENT:	Sumo Strake
TITLE:	6m Tine Hydraulics
	
REVISION:	DATE: 28/06/2013 INITIAL: MH

Drawings and design information found herein remain the sole property of Sumo UK Ltd. Reproductions may only be made with the permission of the owner.

# 6.8 8m Strake tine hydraulics

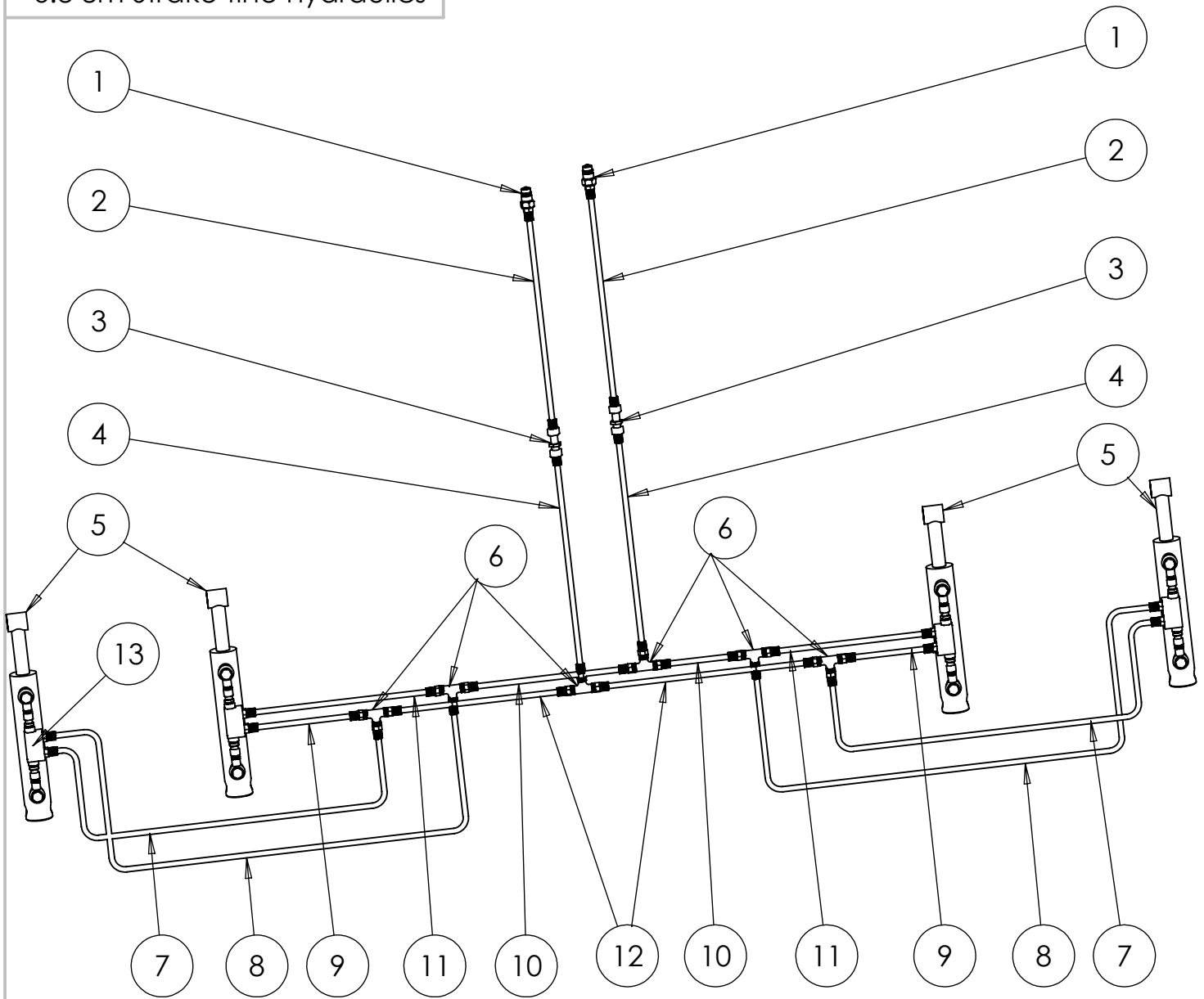

ITEM	PART NO	DESCRIPTION
1	SWH147	Male quick couple spool valve
2	SWH464	Wing tine hydraulic pipe
3	SWH158	12L Bulkhead fitting
4	SWH460	Wing tine hydraulic pipe
5	SWH107	702-2 Ram
6	SWH156	12L Tee branch
7	SWH469	Wing tine hydraulic pipe
8	SWH470	Wing tine hydraulic pipe
9	SWH471	Wing tine hydraulic pipe
10	SWH472	Wing tine hydraulic pipe
11	SWH473	Wing tine hydraulic pipe
12	SWH474	Wing tine hydraulic pipe
13	SWH296	Pilot operated check valve

DO NOT SCALE DRAWING

MACHINE/COMPONENT:

Sumo Strake

TITLE:

8m Tine hydraulics



Drawings and design information found herein remain the sole property of Sumo UK Ltd. Reproductions may only be made with the permission of the owner.

REVISION:

DATE: 01/07/2013

INITIAL: MH

## 6.9 light and light arm

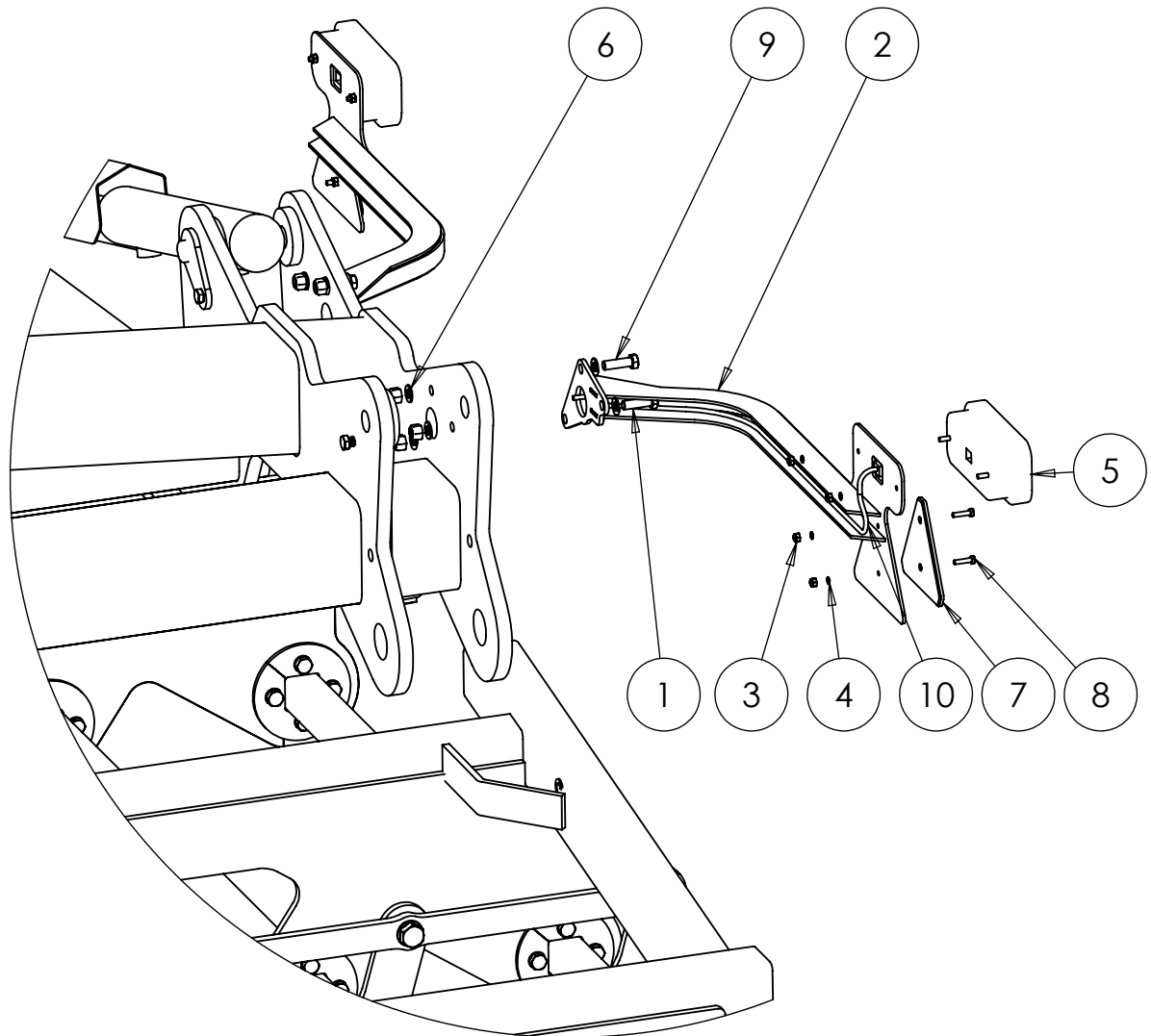

ITEM	PART NO	DESCRIPTION
1	SWM1250	M12 X 50 Bolt
2	SW1210	Light bracket L/H
3	SWM6004	M6 Nylock nut
4	SWM6001	M6 Flat washer
5	SWB174	Rear light unit
6	SWM12001	M12 Flat washer
7	SWB162	Warning triangle
8	SWM6025	M6 X 25 Bolt
9	SWN1245	M12 X 45 Bolt
10	SWB555	Wiring loom

DO NOT SCALE DRAWING

MACHINE/COMPONENT:

Sumo Strake

TITLE:

Light and light arm









Drawings and design information found herein remain the sole property of Sumo UK Ltd. Reproductions may only be made with the permission of the owner.

REVISION:

DATE: 02/07/2013

INITIAL: MH

## 6.10 Stickers and Paint

Sticker	Description	Quantity	Part No.
	Big Sumo horizontal sticker 450 x 135 mm	2	SWB125
	Small Strake sticker	2	SWB553
	Big Union Jack sticker 150 x 100mm	2	SWB127
	Vertical Sumo sticker 80 x 295mm	2	SWB128
	Small Union Jack sticker	2	SWB129
	Small Sumo Horizontal Sticker	4	SWB130
Sumo touch up paint	Sumo Red	1/2 Litre	SWB131
	Sumo Black	1/2 Litre	SWB132